

**CATALOGO PARTI DI RICAMBIO - PARTS CATALOG
CATALOGUE PIECES DE RECHANGE - ERSATZTEILKATALOG
CATALOGO PIEZAS DE REPUESTO**



Part. N° 8000 A2956

**WRE 125 DUAL
PURPOSE-
SM 125 S / 2004**

INFORMAZIONI GENERALI

Il presente catalogo serve per richiedere con esattezza le parti di ricambio.

Nelle ordinazioni indicare:

- 1) il numero di codice dei particolari seguito dalla descrizione;
- 2) il colore per i pezzi verniciati o comunque colorati;
- 3) il numero di matricola del motociclo, stampigliato sul canotto di terzo.

Le indicazioni destra e sinistra si riferiscono ai lati del veicolo rispetto al senso di marcia.

GENERAL INFORMATION

The present spare parts list enables one to order exactly the right spare parts.

When ordering specify:

- 1) the part's code number followed by its description;
- 2) indicate colour for painted or coloured parts;
- 3) the motorcycle's serial number, stamped on the steering head.

References to right and left apply to the vehicle in terms of its direction of movement.

INFORMATIONS GENERALES

Ca catalogue permet de commander correctement les pièces de rechange.

Les commandes doivent être passées en indiquant:

- 1) le numéro de code des pièces détachées suivi de leur description;
- 2) le couleur des pièces peintes ou colorés;
- 3) le matricule de la moto, estampillé sur la tige du guidon.

Droite et gauche sont les côtés du véhicule par rapport au sens de la marche.

ALLGEMEINE HINWEISE

Dieser Ersatzteilkatalog dient zur genauen Angabe der Teile bei Ersatzteilbestellungen.

Bei Ersatzbestellung ist folgendes anzugeben:

- 1) Die Bestellnummer der Ersatzteile mit der entsprechenden Beschreibung;
- 2) Farbe für lackierte und farbige Teile angeben;
- 3) Die Seriennummer des Motorrads, die am Lenkrohr eingepreßt ist. Die Angaben rechts und links beziehen sich auf das Fahrzeug in Fahrrichtung.

INFORMACIONES GENERALES

El presente catálogo sirve para pedir con exactitud las partes de recambio.

En los pedidos se debe indicar:

- 1) el número de código de la parte y a continuación la descripción;
- 2) el color para las piezas barnizadas o coloreadas;
- 3) el número de matrícula de la motocicleta, estampado en el tubo de dirección.

Las indicaciones derecha e izquierda se refieren a los lados del vehículo respecto del sentido de marcha.

Note - List - Notes - Note - Notas:

- A : In alternativa - In alternative - En alternative - Wahlweise - En alternativa
 C : Fornire in coppia - Delivered by pairs - Livrées par paire
 Paarweise Geliefert - Equipar por parejas
 D : In dotazione - To issue - En nécessaire - Ausrüstungsteile - En dotación
 E : Fornire fino ad esaurimento - To fell out - A' finir - Erschöpfung
 A agotamiento
 F : Fornire assieme - Supply unitedly - Fournir ensemble
 Wird zusammen Geliefert - Equipar juntos
 H : Contenuto in busta guarnizioni - It's contained in the gasket set
 Contenu entre l'enveloppe du joints - In den Reparaturendichtungsatz
 Se encuentra en la bolsa de guarniciones
 R : A richiesta - Upon request - Sur demande - Auf Anfrage - Bajo pedido
 N : Non fornito - Not supplied - Ne pas fournit - Nicht Versorgt - No se provee
 W : Modello WRE - WRE model - Modèle WRE - Modell WRE - Modelo WRE
 W : Di serie su modello WRE - Supplied for WRE model
 De série pour modèle WRE - Standard für WRE modell
 De serie por modelo WRE
 S : Modello SMS - SMS model - Modèle SMS - Modell SMS - Modelo SMS
 S : Di serie su modello SMS - Supplied for SMS model
 De série pour modèle SMS - Standard für SMS modell
 De serie por modelo SMS
 Z : n° denti, number of teeth, numéro dents, Zähne nummer,
 número dientes

- A : Austria, Austria, Autriche, Österreich, Austria
 AUS : Australia, Australia, Australie, Australien, Australia
 B : Belgio, Belgium, Belgique, Belgien, Bélgica
 BR : Brasile, Brazil, Brésil, Brasilien, Brasil
 CDN : Canada, Canada, Canada, Kanada, Canadá
 CH : Svizzera, Switzerland, Suisse, Schweizer, Suiza
 D : Germania, Germany, Allemagne, Deutschland, Alemania
 E : Spagna, Spain, Espagne, Spanien, España
 F : Francia, France, France, Frankreich, Francia
 GB : Gran Bretagna, Great Britain, Grand Bretagne
 Groos Britan, Gran Bretaña
 I : Italia, Italy, Italie, Italien, Italia
 J : Giappone, Japan, Japon, Japan, Japón
 SF : Finlandia, Finald, Finlande, Finnland, Finlandia
 USA : Stati Uniti d'America, United States of America, Etats Units d'Amerique,
 Vereinigte Staaten von Amerika, Estados Unidos

Validità - Validity - Validité - Gultig - Validez:

- F.m. : Fino alla matricola - Until V.I.N. - Jusqu'au matricule
 Bis zu Matrikel - Hasta la matrícula
 D.m. : Dalla matricola - From V.I.N. - Du matricule - Vom Matrikel
 Desde la matrícula

Il n° di matricola iniziale del modello WRE 125 è ZCGH300AA4V003622

Il n° di matricola iniziale del modello SM 125 S è ZCGH300AB4V003622

The initial serial number for the WRE 125 model is ZCGH300AA4V003622

The initial serial number for the SM 125 S model is ZCGH300AB4V003622

Le matricule initial du modèle WRE 125 est ZCGH300AA4V003622

Le matricule initial du modèle SM 125 S est ZCGH300AB4V003622

Die Seriennummer des Modells WRE 125 beginnt mit ZCGH300AA4V003622

Die Seriennummer des Modells SM 125 S beginnt mit ZCGH300AB4V003622

El n° de matrícula inicial de la motocicleta WRE 125 es ZCGH300AA4V003622

El n° de matrícula inicial de la motocicleta SM 125 S es ZCGH300AB4V003622

Codice colore "E" moto "giallo-blu"

Colour code "E" "yellow-blue" motorcycle

Code couleur "E" moto "jaune-bleu"

Code Farbe "E" motorrad "Gelb-Blau"

Codigo de color "E" moto "amarillo-azul".

Codice colore "G" moto "nera-blu"

Colour code "G" "black-blue" motorcycle

Code couleur "G" moto "noir-bleu"

Code Farbe "G" motorrad "Schwarz-Blau"

Codigo de color "G" moto "negro-azul".

Dati indicativi soggetti a modifiche senza impegno di preavviso.

All data are subject to modification without prior notice.

Données indicatif sujet au modifications sans obligation de préavis.

Anderungen vorbehalten.

Datos indicativos sujetos a modificaciones sin compromiso de preaviso.

Tavola Drawing Table Bild Tabla	Denominazione	Description	Designation	Bezeichnung	Denominacion	Pagina Page Page Seite Paja
1	ATTREZZI DI ASSISTENZA	SERVICE TOOLS	OUTILS D'ASSISTANCE	HILFAUSRUSTUNG	HERRAMIENTAS DE ASISTENCIA	11
2	TESTA CILINDRO, PISTONE, MANOVELLISMO	CYLINDER HEAD, CYLINDER, PISTON, CRANKSHAFT	CULASSE, CYLINDRE, PISTON, VILEBREQUIN	ZYLINDERKOPF, ZYLINDER, KOLBEN, KURBELWELLE	CULATA, CILINDRO, PISTON, PALANCAS	13
3	H.T.S.	H.T.S.	H.T.S.	H.T.S.	H.T.S.	19
4	RAFFREDDAMENTO	COOLING	REFROIDISSEMENT	WASSERKÜHLUNG	ENFRIAMIENTO	23
5	BASAMENTO	CRANKCASE	CARTER	GEHAUSE	BANCADA	27
6	COPERCHI BASAMENTO	CRANKCASE COVERS	COUVERCLES CARTER	GEHAUSEDECKEL	TAPA BANCADA	31
7	FRIZIONE, TRASMISSIONE PRIMARIA	CLUTCH, PRIMARY DRIVE	EMBAYAGE, TRANSMISS. PRIMARIE	KUPPLUNG, ERSTERANTRIEB	EMBRAGUE, TRANSM. PRIMARIA	33
8	CAMBIO	TRANSMISSION	BOITE DE VITESSE	WECHSELGETRIEBE	CAMBIO	37
9	COMANDO CAMBIO	SHIFTER	COMMANDE DE VITESSE	GANGSCHALTUNG	MANDO CAMBIO	41
10	LUBRIFICAZIONE	OIL PUMP AND DRIVE	PUMPE HUILE	MOTORSHMIERUNG	LUBRICATION	43
11	PARTE ELETTRICA	ELECTRIC PART	PARTIE ELECTRIQUES	ELEKTRISCHETEILE	PARTE ELECTR.	45
11A	AVVIAMENTO A PEDALE	KICK STARTER	PEDAL DE MISE EN MARCHE	ANLASSER	PUESTA EN MARCHA A PEDAL	47
12	CARBURATORE	CARBURETOR	CARBURATEUR	VERGASER	CARBURADOR	49
13	FILTRO ARIA	AIR FILTER	FILTRE AIRE	AIRFILTER	FILTRO DE AIRE	53
14	TELAIO, PEDANE	FRAME, FOOT RESTS	CADRE, REPOSE PIEDS	RAHMEN, FUSSBRETT	BASTIDOR, REPOSAPIES	55
15	SOSPENSIONE ANTERIORE	FRONT FORK ASSEMBLY	SUSPENSION AVANT	VORDERTELESKOPGABEL	SUSPENSION DELANTERA	59
16	FORCELLONE	SWING ARM	FOURCHE	GABEL	HORQUILLA	63
16A	LEVERAGGI SOSPENSIONE POST.	REAR SUSPENSION LINKAGE	LEVIER SUSPENSION ARRIERE	HEBELWERK HINTERHAUFHANGUNG	PALANCA SUSPENSION TRASERA	67
16B	AMMORTIZZATORE POSTERIORE	REAR SUSPENSION	SUSPENSION ARRIERE	HINTERHAUFHANGUNG	SUSPENSION TRASERA	
	(WRE -SMS)	(WRE -SMS)	(WRE -SMS)	(WRE -SMS)	(WRE -SMS)	69
16C	AMMORTIZZATORE POSTERIORE	REAR SUSPENSION	SUSPENSION ARRIERE	HINTERHAUFHANGUNG	SUSPENSION TRASERA	
	(SMS)	(SMS)	(SMS)	(SMS)	(SMS)	71
17	MANUBRIO E COMANDI	HANDLEBAR AND CONTROLS	GUIDON ET COMMANDES	LENKER UND STEUERORGANE	MANILLAR Y MANDOS	73
18	FRENO IDRAULICO POSTERIORE	REAR HYDRAULIC BRAKE	FREIN HYDRAULIQUE ARRIERE	HINTERBREMSE	FRENO HIDRAULICO TRASERO	75
19	PANNELLI LAT., PARAFANGHI, SELLA	SIDE PANELS, FENDERS, SEAT	PANNEAU, GARDE-BOUES , SIEGE	STREIFEN, KOTFLUGEL, SATTEL	PANELES, GUARDABARROS, SILLIN	77
20	SERBATOIO, CONVOGLIATORI	GAS TANK, SPOILERS	RESERVOIR, FLANC	KRAFTSTOFFBEHALTER, FLANKEN	DEPOSITO, LATERALES	79
21	SCARICO	EXHAUST SYSTEM	TUYAU D'ECHAPPEMENT	AUSPUFFROHR	TUBO DE ESCAPE	81
22	FRENO IDRAULICO ANTERIORE	FRONT HYDRAULIC BRAKE	FREIN HYDRAULIQUE AVANT	VORTERBREMSE	FRENO HIDRAULICO DELANTERO	83
22A	RUOTA ANTERIORE	FRONT WHEEL	ROUE AV.	VORTERRAD	RUEDA DELANTERA	85
23	RUOTA POSTERIORE	REAR WHELL	ROUE ARRIERE	HINTERRAD	RUEDA TRASERA	89
24	CONTACHILOMETRI, AVVISATORE ACUSTICO	SPEEDOMETER, HORN	COMPTEKILOMETRES, SIGNAL ACOUSTIQUE	TACHOMETER, HUPE	CUENTA-KILOMETROS, AVISADOR ACUSTICO	93

Tavola Drawing Table Bild Tabla	Denominazione	Description	Designation	Bezeichnung	Denominacion	Pagina Page Seite Paja
25	IMPIANTO ELETTRICO, PORTATARGA	ELECTRIC SYSTEM, PLATE HOLDER	INSTALLATION ELECT.,PORTE-BALAI	ELEKTR. ANLAGE, SCHILDTRAEGER	INSTALAC. ELECT., PORTA-MATRICULA	95
26	FRECCE	BLINKER	CLIGNOTANT	BLINKER	INTERMITENTE	99
27	DECALC. CODICE COLORE "E" (WRE)	TRANSFERS COLOR CODE "E" (WRE)	DECAL. CODE COLOR "E" (WRE)	ABZIEHBILD CODE FABRE "E" (WRE)	CALCOMANIA COD. COLOR "E" (WRE)	101
28	DECALC. CODICE COLORE "E" (SMS)	TRANSFERS COLOR CODE "E" (SMS)	DECAL. CODE COLOR "E" (SMS)	ABZIEHBILD CODE FABRE "E" (SMS)	CALCOMANIA COD. COLOR "E" (SMS)	103
29	DECALC. CODICE COLORE "G" (SMS)	TRANSFERS COLOR CODE "G" (SMS)	DECAL. CODE COLOR "G" (SMS)	ABZIEHBILD CODE FABRE "G" (SMS)	CALCOMANIA COD. COLOR "G" (SMS)	105
-	INDICE NUMERICO PROGRESSIVO	NUMERICAL INDEX	INDEX NUMERIQUE	NUMMERNVERZEICHNIS	ÍNDICE NUMÉRICO PROGRESIVO	106

Tavola - Drawing - Table - Bild - Tabla

1

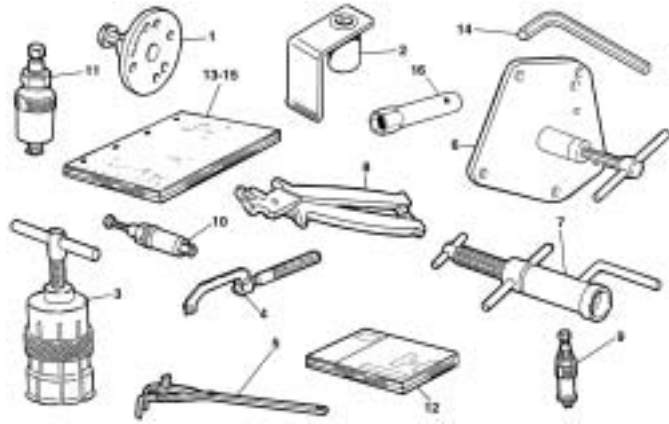

Pagina - Page - Page - Seite - Paja

10

Tavola - Drawing - Table - Bild - Tabla

2

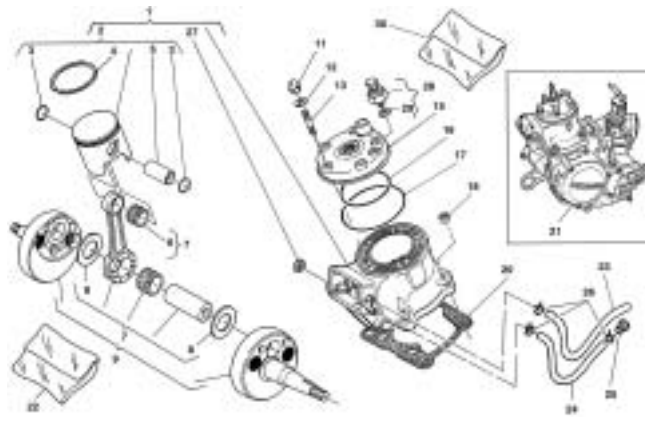

Pagina - Page - Page - Seite - Paja

12

Tavola - Drawing - Table - Bild - Tabla

3

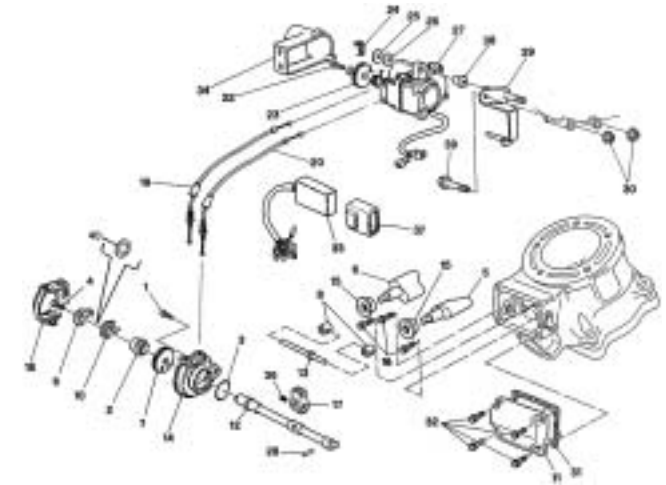

Pagina - Page - Page - Seite - Paja

18

Tavola - Drawing - Table - Bild - Tabla

4

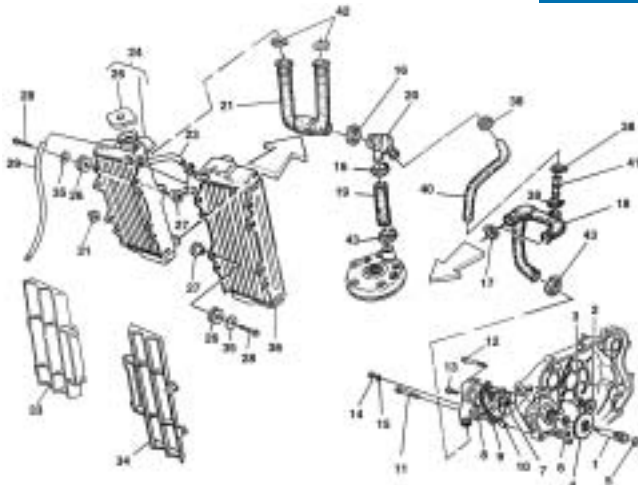

Pagina - Page - Page - Seite - Paja

22

Tavola - Drawing - Table - Bild - Tabla

5

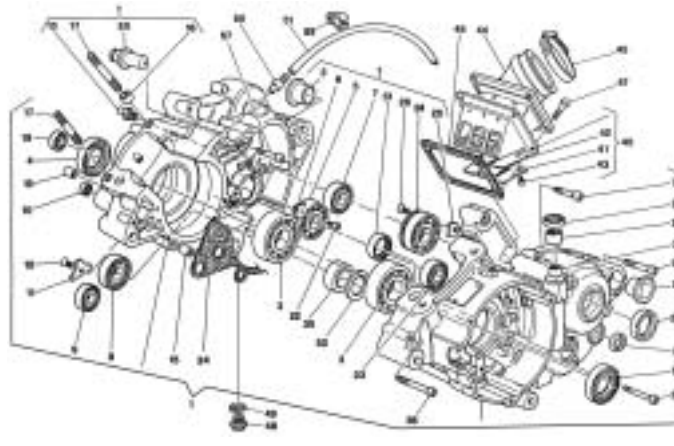

Pagina - Page - Page - Seite - Paja

26

Tavola - Drawing - Table - Bild - Tabla

6

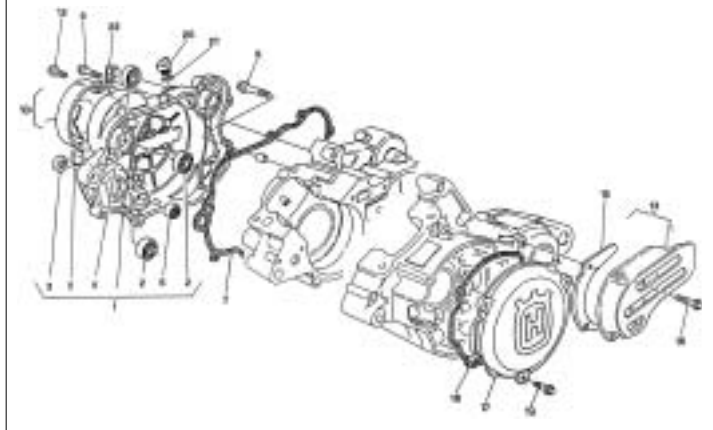

Pagina - Page - Page - Seite - Paja

30

Tavola - Drawing - Table - Bild - Tabla

7

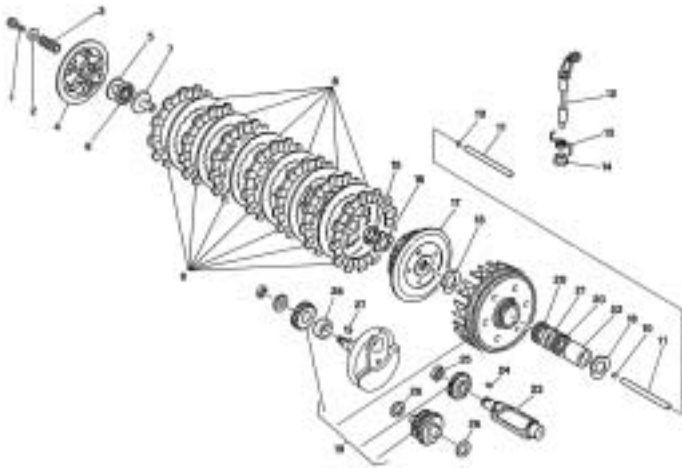

Pagina - Page - Page - Seite - Paja

32

Tavola - Drawing - Table - Bild - Tabla

8

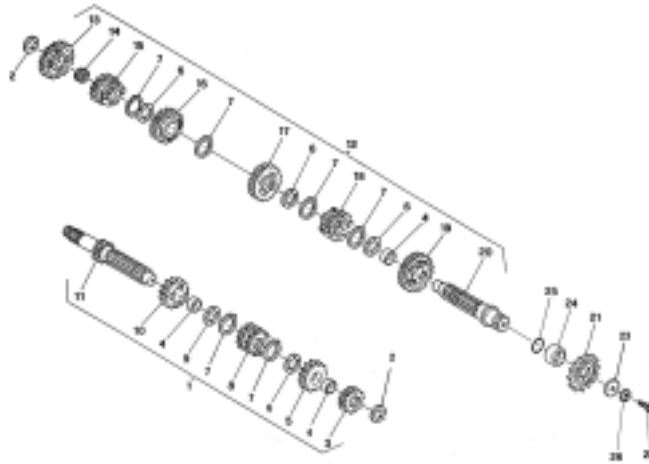

Pagina - Page - Page - Seite - Paja

35

Tavola - Drawing - Table - Bild - Tabla

9

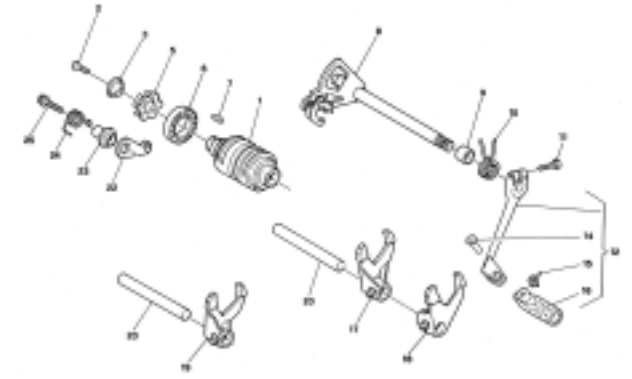

Pagina - Page - Page - Seite - Paja

40

Tavola - Drawing - Table - Bild - Tabla

10

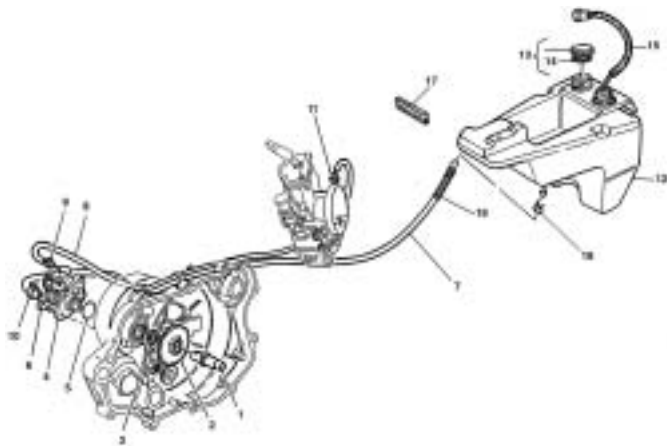

Pagina - Page - Page - Seite - Paja

42

Tavola - Drawing - Table - Bild - Tabla

11

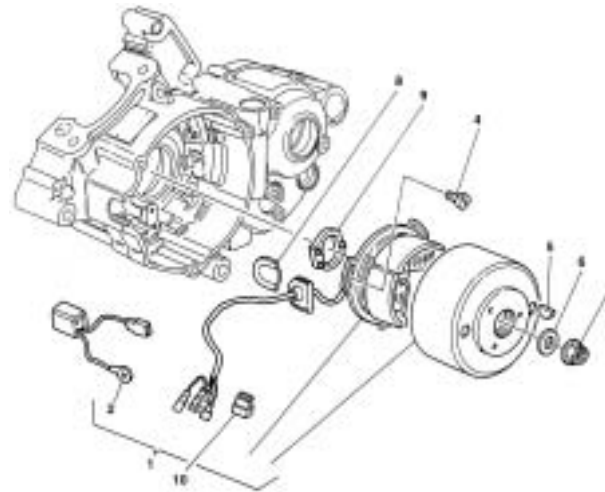

Pagina - Page - Page - Seite - Paja

44

Tavola - Drawing - Table - Bild - Tabla

11A

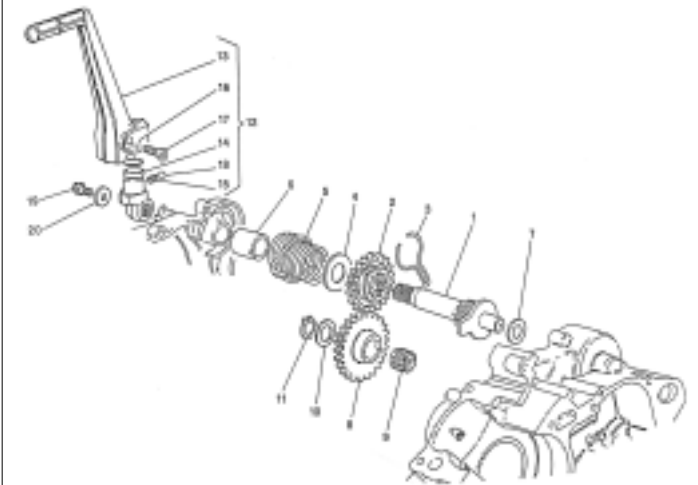

Pagina - Page - Page - Seite - Paja

46

Tavola - Drawing - Table - Bild - Tabla

12

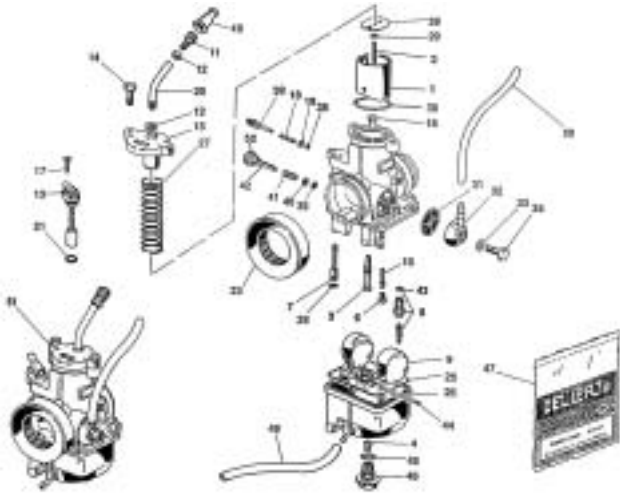

Pagina - Page - Page - Seite - Paja

48

Tavola - Drawing - Table - Bild - Tabla

13

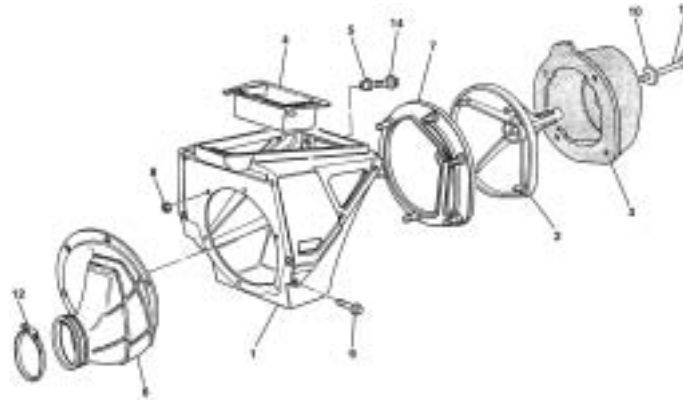

Pagina - Page - Page - Seite - Paja

52

Tavola - Drawing - Table - Bild - Tabla

14

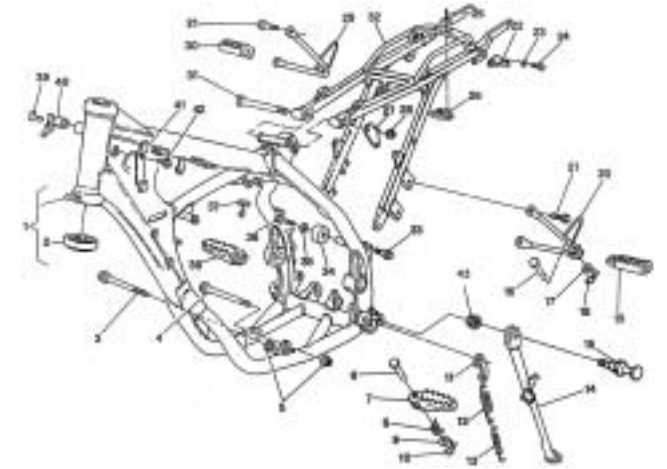

Pagina - Page - Page - Seite - Paja

54

Tavola - Drawing - Table - Bild - Tabla

15

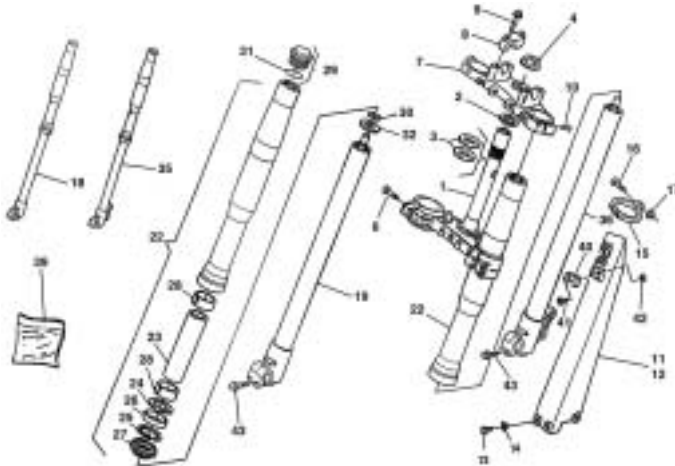

Pagina - Page - Page - Seite - Paja

58

Tavola - Drawing - Table - Bild - Tabla

16

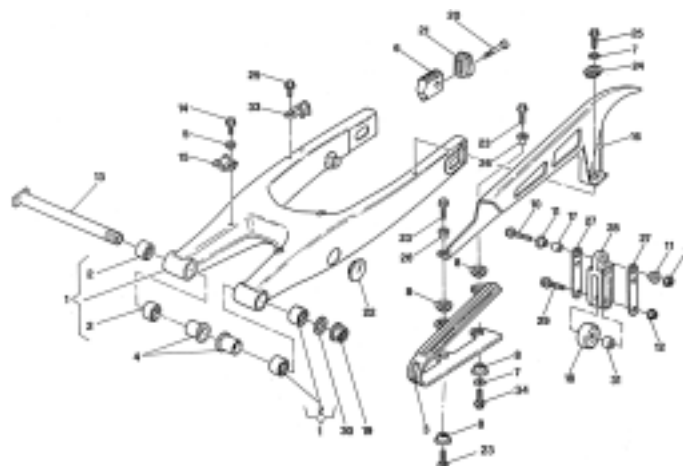

Pagina - Page - Page - Seite - Paja

62

Tavola - Drawing - Table - Bild - Tabla

16A

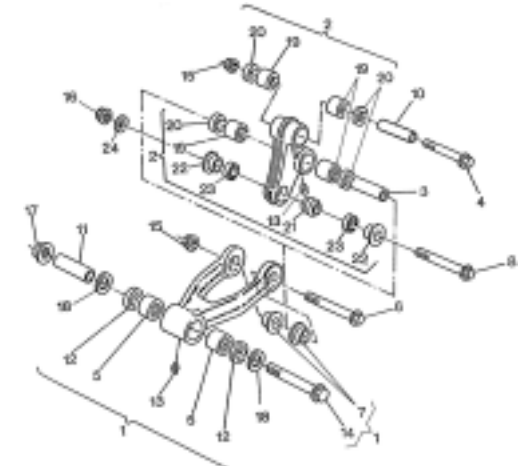

Pagina - Page - Page - Seite - Paja

66

Tavola - Drawing - Table - Bild - Tabla

16B

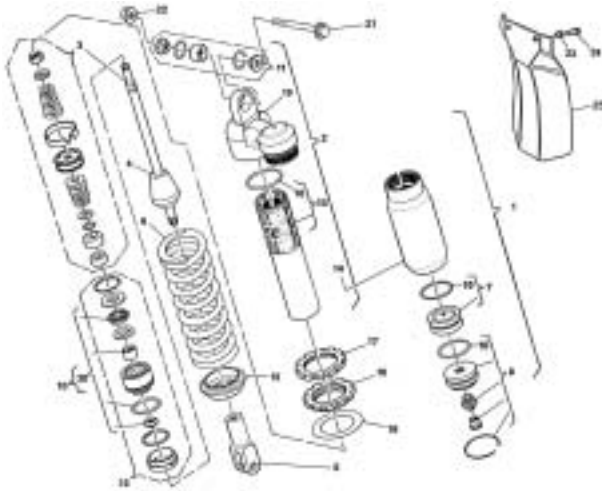

Pagina - Page - Page - Seite - Paja

68

Tavola - Drawing - Table - Bild - Tabla

16C

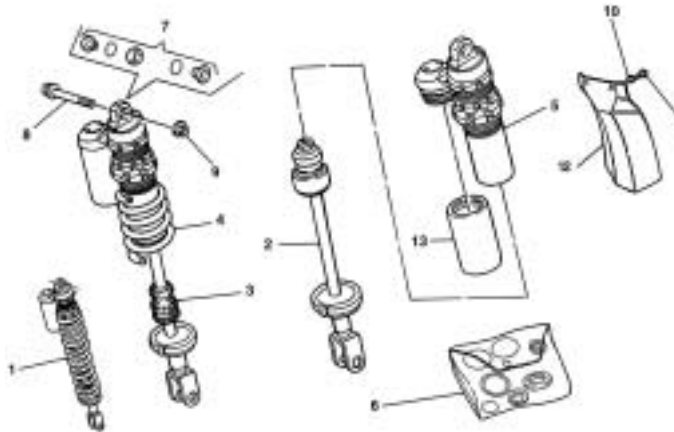

Pagina - Page - Page - Seite - Paja

70

Tavola - Drawing - Table - Bild - Tabla

17

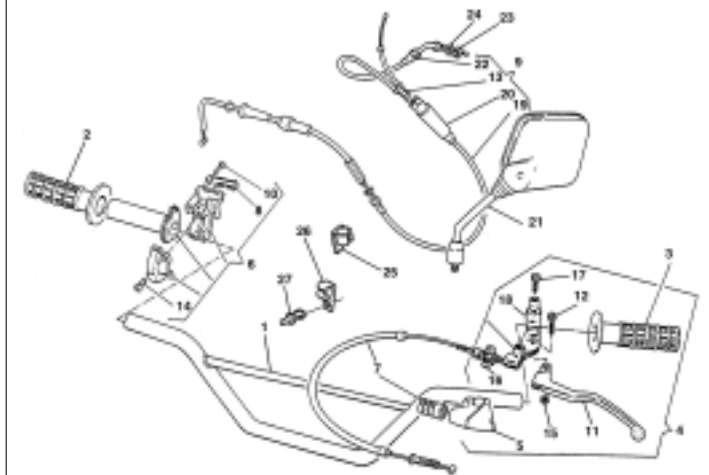

Pagina - Page - Page - Seite - Paja

72

Tavola - Drawing - Table - Bild - Tabla

18

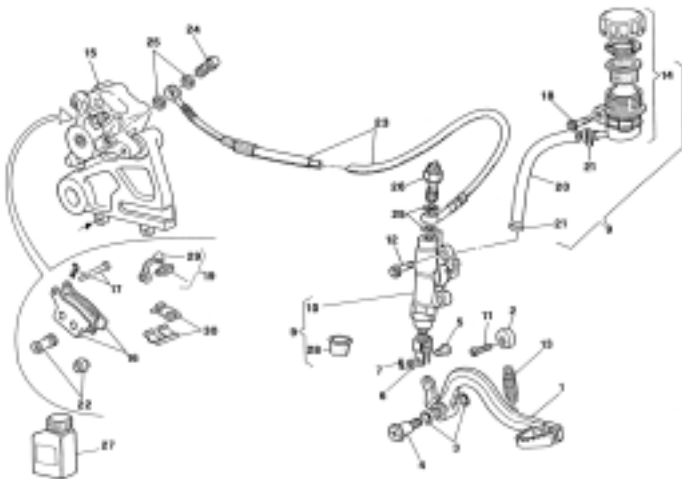

Pagina - Page - Page - Seite - Paja

74

Tavola - Drawing - Table - Bild - Tabla

19

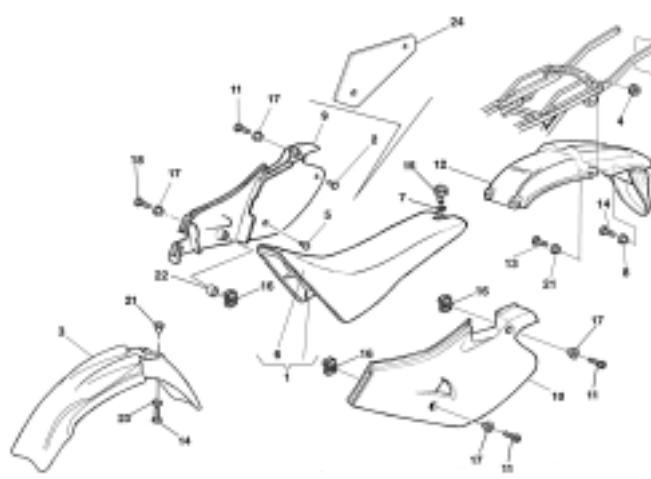

Pagina - Page - Page - Seite - Paja

76

Tavola - Drawing - Table - Bild - Tabla

20

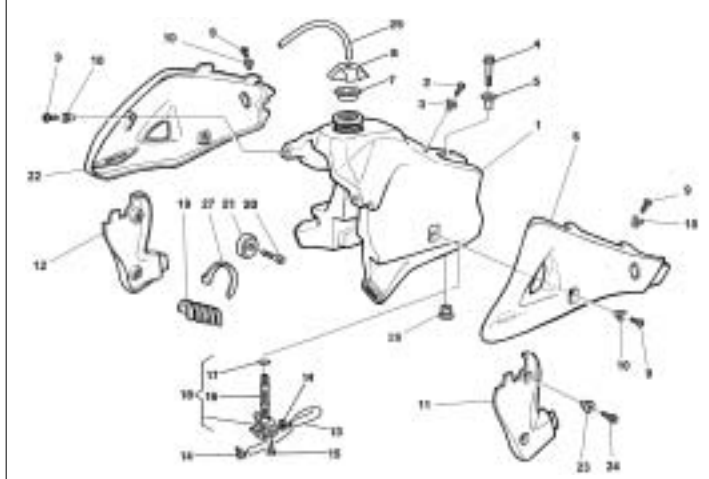

Pagina - Page - Page - Seite - Paja

78

Tavola - Drawing - Table - Bild - Tabla

21

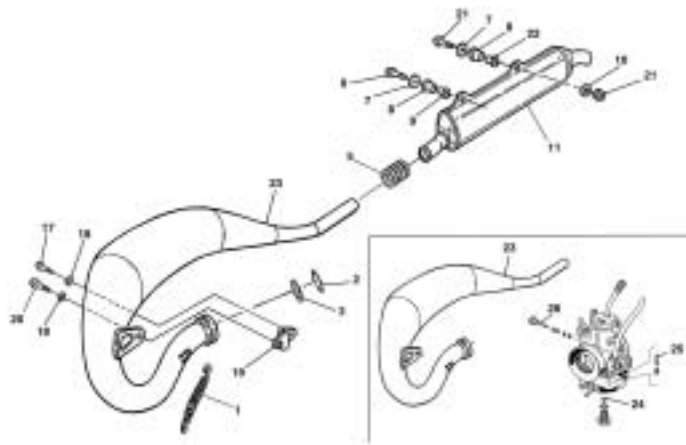

Pagina - Page - Page - Seite - Paja

80

Tavola - Drawing - Table - Bild - Tabla

22

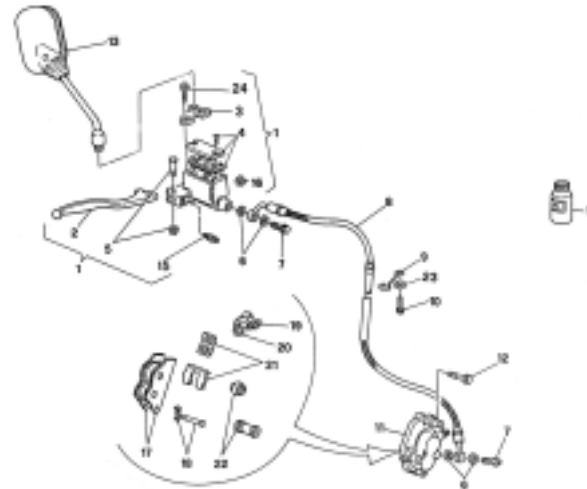

Pagina - Page - Page - Seite - Paja

82

Tavola - Drawing - Table - Bild - Tabla

22A

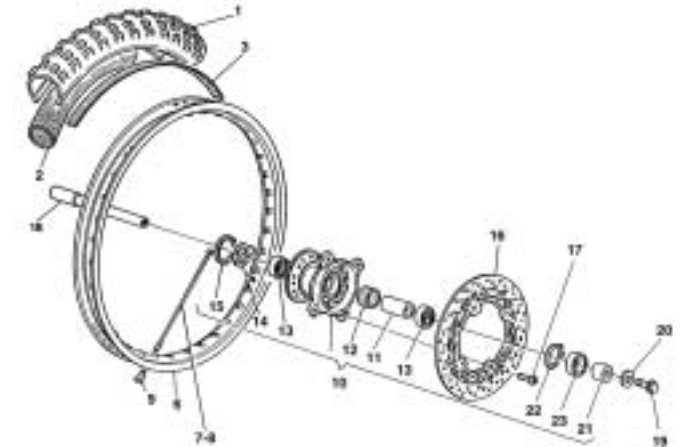

Pagina - Page - Page - Seite - Paja

84

Tavola - Drawing - Table - Bild - Tabla

23

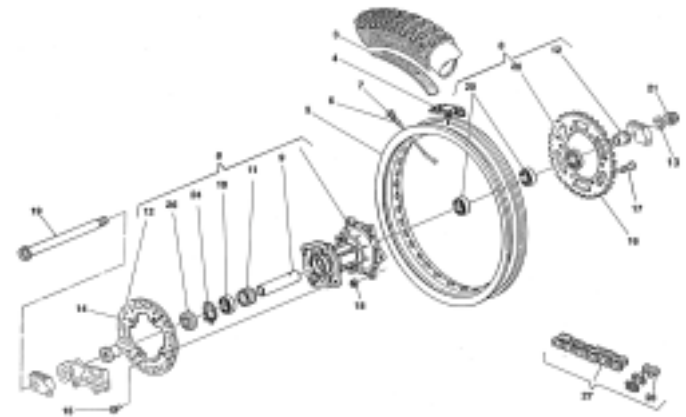

Pagina - Page - Page - Seite - Paja

88

Tavola - Drawing - Table - Bild - Tabla

24

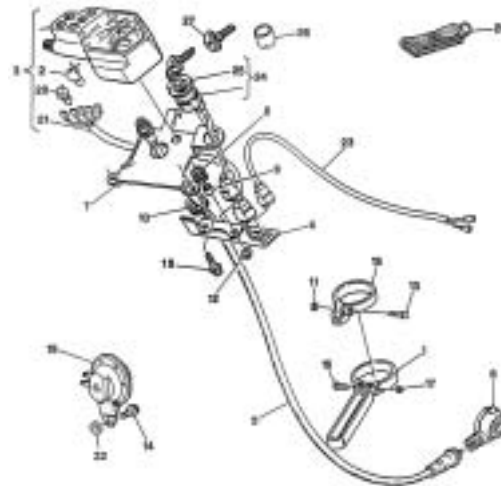

Pagina - Page - Page - Seite - Paja

92

Tavola - Drawing - Table - Bild - Tabla

25

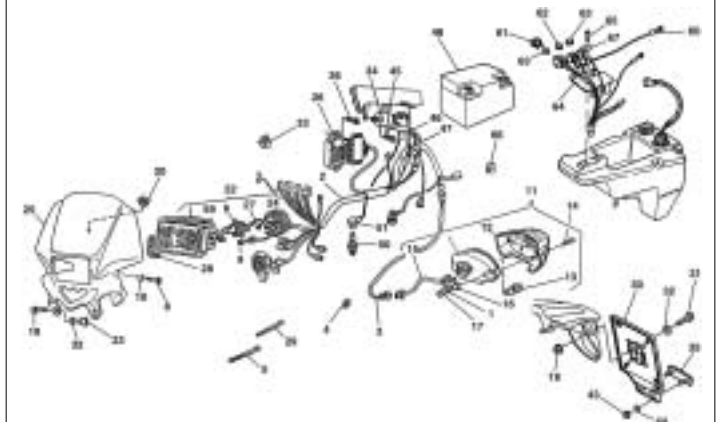

Pagina - Page - Page - Seite - Paja

94

Tavola - Drawing - Table - Bild - Tabla

26

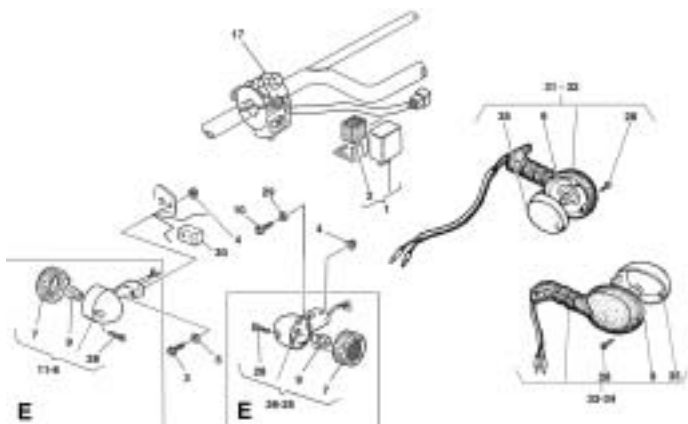

Pagina - Page - Page - Seite - Paja

98

Tavola - Drawing - Table - Bild - Tabla

27



Pagina - Page - Page - Seite - Paja

100

Tavola - Drawing - Table - Bild - Tabla

28



Pagina - Page - Page - Seite - Paja

102

Tavola - Drawing - Table - Bild - Tabla

29



Pagina - Page - Page - Seite - Paja

104

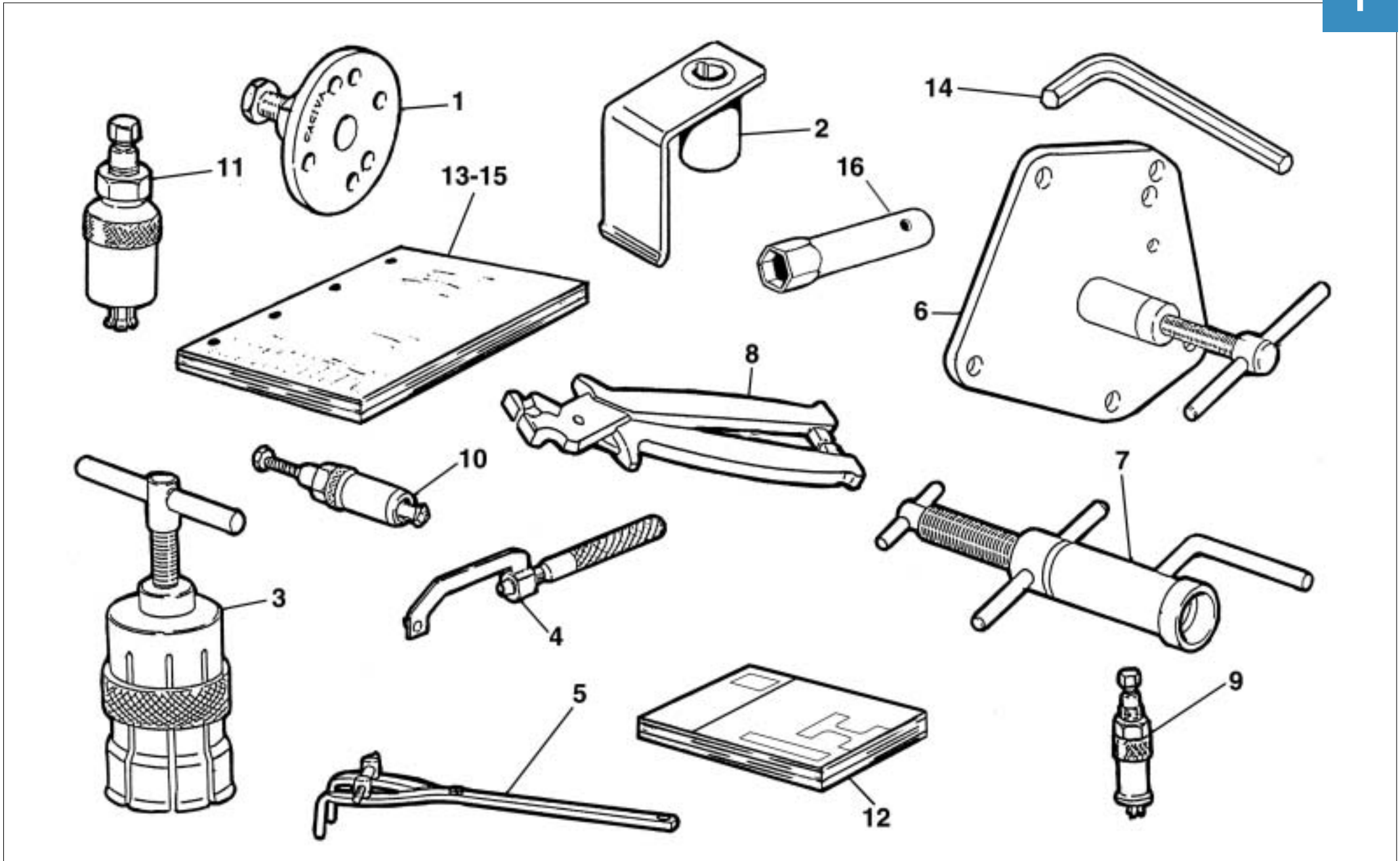

Note Notes Notes Marke Notas	Pos. No. N. Index Pos.	N. Cod. Code No. Nr. Code Code Nr N. Cod.	Q.tà Q.ty Q.te M.ge C.ad	DENOMINAZIONE	NAME	DESIGNATION	BESHREIBUNG	DENOMINACION	Validità Validity Validité Gültig Validez
	1	8000 51614	1	Estrattore volano	Flywheel extractor	Extracteur pour volant	Auszieher für Schwungrad	Extractor volante	
	2	8000 48803	1	Attrezzo controllo fase accens.	Ignition control tool	Outil surveillance allumage	Werkzeug zur Kontrolle der Zündung	Herramienta control fase encendido	
	3	8000 89030	1	Estrattore per cuscinetto albero motore	Crankshaft bearing extractor	Extracteur pour roulement vilebrequin	Auszieher für Antriebswellelager	Extractor coijnete cigüeñal	
	4	000Y A2273	1	Chiave fermo pignone	Pinion lock wrench	Cléf arrêt pinion	Schlüssel f. ritzelsperrung	Llave parado pinon	
	5	8000 79015	1	Chiave per mozzo frizione	Clutch hub retaining wrench	Cléf arrêt moyeu embrayage	Schlüssel radnabe	Llave cubo friccion	
	6	8000 79016	1	Attrezzo sep. semicarter e smont. albero motore	Crankcase splitting tool and crankshaft disassembly	Outil pour demontage carters et vilebrequin	Werkzeug für Trennung Gehäusehälfte und	Herramienta semi-carter	
	7	8000 79017	1	Attrezzo mont. alb. motore nel carter	Installing tool crankshaft	Outil mont. vilebrequin gehäuse	Werkzeug zur Mont. Kurbelwelle im demicarter	Herram. mont. eje motore	
	8	8000 49767	1	Pinza montaggio fascette	Clamp installing plier	Pince pour montage collier	Schellenzange	Pinza montaje abrazaderas	
	9	8000 43824	1	Estrattore per cusc. a rullini rinvio comando valvola, cuscinetto pompa acqua e comando valvola	Puller, exhaust valve layshaft needle bearings, water pump shaft ball bear. and exhaust valvedrive regulator ball bear	Extracteur pour coquillé à aiguille renvoi com. soupape, palier pompe et renvoi com. soupape	Werkzeug für Rollenlager, Vorgelege, Ventilsteuerung Lager, Wasserpumpe und, Vorgelege	Extractor cijnete de rulos man- do valvula y bomba agua	
	10	8000 33054	1	Estrattore cuscinetto a rullini albero pompa olio	Needle bearing oil pump shaft extractor	Extrac. pour roulement arbre pompe à huile	Auszieher für Nadelkäfig Oelpumpenwelle	Extrac. cijnete de rodillos eje bomba aceite	
	11	8000 43720	1	Estrattore per cuscinetto albero com. cambio	Puller, gear shifter cam ball bearing	Extracteur pour roulement	Werkzeug für Lager, Scaltwelle	Extractor coijneteje cambio	
D	12	8000 A2917	1	Libretto uso e manutenzione	Owner's manual	Emploi d'entretien	Betriebsanleitung	Manual uso y mantenimiento	
R	13	8000 A2918	1	Manuale di officina	Workshop manual	Manuel d'atelier	Werkstatthandbuch	Manual de oficina	
	14	8000 98431	1	Chiave per viti antimanomissione	"Antitampering"screw wrench	Clef pour vis "Antitampering"	"Antitampering" Schraubeschlüssel	Llave por tornillos "Antitampering"	
R	15	8000 A2916	1	Catalogo parti di ricambio	Spare parts catalog	Catalogue piece de rechange	ERSATZTEILKATALOG	Catalogo piezas de repuesto	
	16	1619 69801	1	Chiave per candela	Spark plug wrench	Cléf pour bougie	Schlüssel f. Zundkerze	Llave bujia	

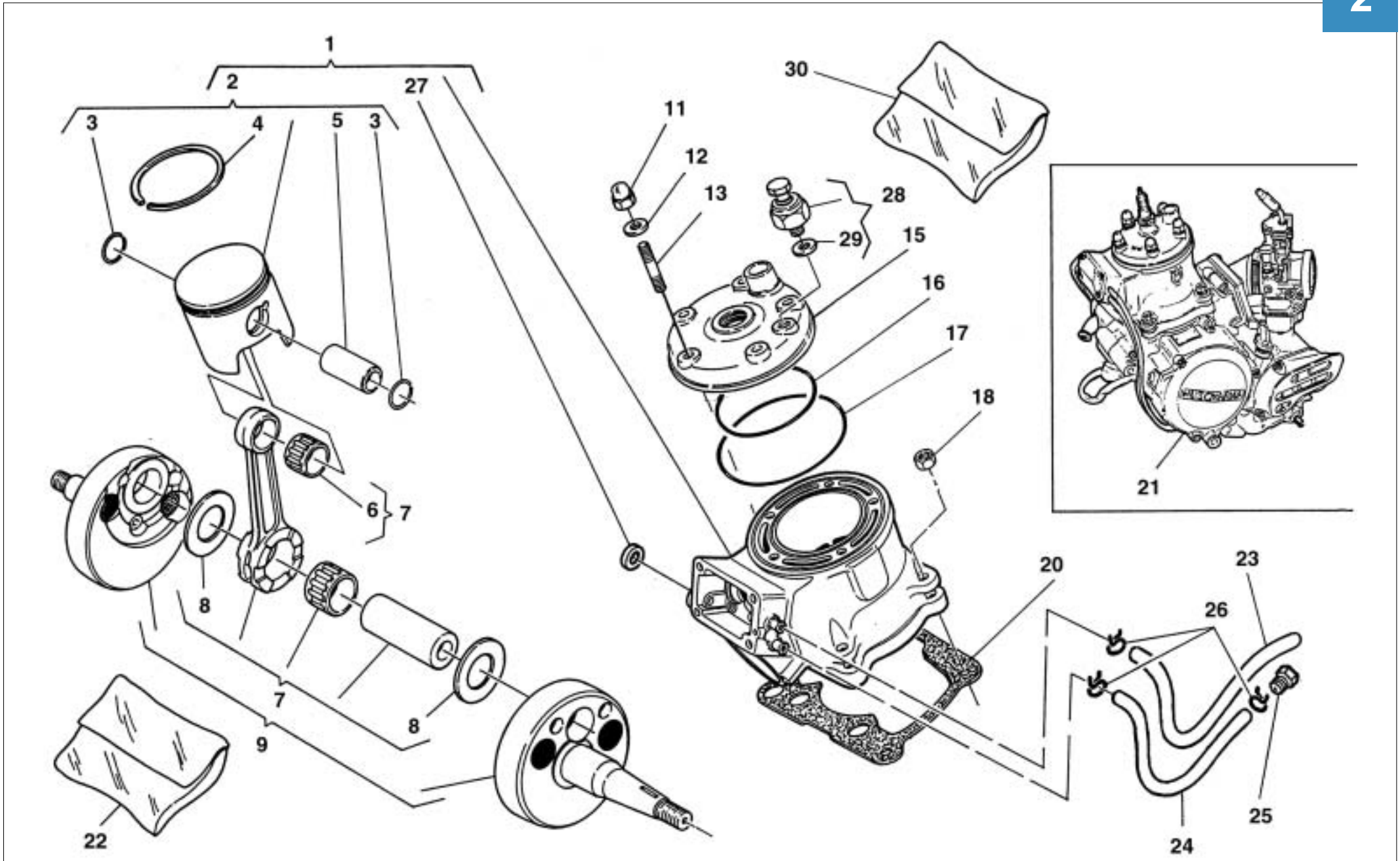

Note Notes Marke Notas	Pos. No. Index Pos.	N. Cod. Code No. Nr. Code Code Nr N. Cod.	Q.tà Q.ty Q.te M.ge C.ad	DENOMINAZIONE	NAME	DESIGNATION	BESHREIBUNG	DENOMINACION	Validità Validity Validité Gültig Validez
	1	8000 A1242	1	Cilindro completo	Cylinder assy	Cylindre compl.	Zylinder kpl.	Cilindro compl.	
	2	8000 99749/1	1	Pistone completo	Compl. piston	Piston complet	Kolben, kpl.	Pistón completo	
				A-B (ø 53,940÷53,950 mm)	A-B (ø 53,940÷53,950 mm)	A-B (ø 53,940÷53,950 mm)	A-B (ø 53,940÷53,950 mm)	A-B (ø 53,940÷53,950 mm)	
	2	8000 99749/2	1	Pistone completo	Compl. piston	Piston complet	Kolben, kpl.	Pistón completo	
				C-D (ø 53,950÷53,960 mm)	C-D (ø 53,950÷53,960 mm)	C-D (ø 53,950÷53,960 mm)	C-D (ø 53,950÷53,960 mm)	C-D (ø 53,950÷53,960 mm)	
	2	8000 99749/3	1	Pistone completo	Compl. piston	Piston complet	Kolben, kpl.	Pistón completo	
				E-F (ø 53,960÷53,970 mm)	E-F (ø 53,960÷53,970 mm)	E-F (ø 53,960÷53,970 mm)	E-F (ø 53,960÷53,970 mm)	E-F (ø 53,960÷53,970 mm)	
	3	8000 10314	2	Anellino ritegno spinotto	Circlip	Bague d'arret	Federring	Anillo de retención	
	4	8000 99750	1	Segmento	Circlip	Segment	Kolbenring	Segmento	
	5	8000 83066	1	Spinotto	Gudgeon	Axe	Bolzen	Perno	
	6	8000 83071	1	Cuscinetto a rullini (ø15xø19x17,3 mm)	Needle bearing (ø15xø19x17,3 mm)	Roulement à aiguilles (ø15xø19x17,3 mm)	Nadelkafig (ø15xø19x17,3 mm)	Cojinete (ø15xø19x17,3 mm)	
	7	8000 88810	1	Biella motore compl.	Connecting rod compl.	Bielle compl.	Pleuelstange kpl.	Biela motor completa	
	8	8000 50629	2	Rosetta	Washer	Rondelle	Scheibe	Arandela	
E	9	8000 92910	1	Compl. albero motore	Crankshaft assy	Vilebrequin compl.	Kurbewelle kpl.	Cigüeñal compl.	
	9	8000 94658	1	Compl. albero motore	Crankshaft assy	Vilebrequin compl.	Kurbewelle kpl.	Cigüeñal compl.	
	11	61N1 15095	5	Dado	Nut	Ecrou	Mutter	Tuerca	
	12	8000 39335	5	Rosetta	Washer	Rondelle	Scheibe	Arandela	
	13	8000 70627	5	Prigioniero	Stud bolt	Prisonnier	Stiftschraube	Prisionero	
	15	8000 86981	1	Testa cilindro	Cylinder head	Culasse cylindre	Zylinderkopf	Culada cilindro	
	16	8000 39630	1	Anello OR interno	O Ring	Bague OR	O Ring	Anillo OR	
	17	8000 70635	1	Anello OR esterno	O Ring	Bague OR	O Ring	Anillo OR	
	18	80B0 43928	4	Dado frenato	Nut	Ecrou	Mutter	Tuerca	
	20	8000 83068	1	Guarnizione (0,3 mm)	Gasket (0,3 mm)	Garnitue (0,3 mm)	Dichtung (0,3 mm)	Junta (0,3 mm)	
	20	8A00 83068	1	Guarnizione (0,4 mm)	Gasket (0,4 mm)	Garnitue (0,4 mm)	Dichtung (0,4 mm)	Junta (0,4 mm)	
	20	8B00 83068	1	Guarnizione (0,5 mm)	Gasket (0,5 mm)	Garnitue (0,5 mm)	Dichtung (0,5 mm)	Junta (0,5 mm)	
	21	8000 A1240	1	Motore completo	Engine assy	Moteur compl.	Motor kpl.	Guepial compl.	
R	22	8000 94652	1	Gruppo guarnizioni motore	Engine gasket set	Groupe garniture moteur	Dichtunggruppe Motor	Grupo juntas	
	23	8000 83056	1	Tubo sfiato	Pipe	Tuyau	Rohr	Tubo	
	24	8A00 83056	1	Tubo sfiato	Pipe	Tuyau	Rohr	Tubo	
	25	8000 79560	1	Tappo	Plug	Bouchon	Verschluss	Tapòn	
	26	8000 40433	3	Fascetta	Clamp	Collier	Schelle	Banda	
	27	8000 64296	1	Anello di tenuta (ø8ø16Sp5)	Seal ring (ø8ø16Th.5)	Bague de retenue(ø8ø16ép.5)	Dichtring (ø8xø16xS.5)	Anillo retención (ø8ø16esp.5)	

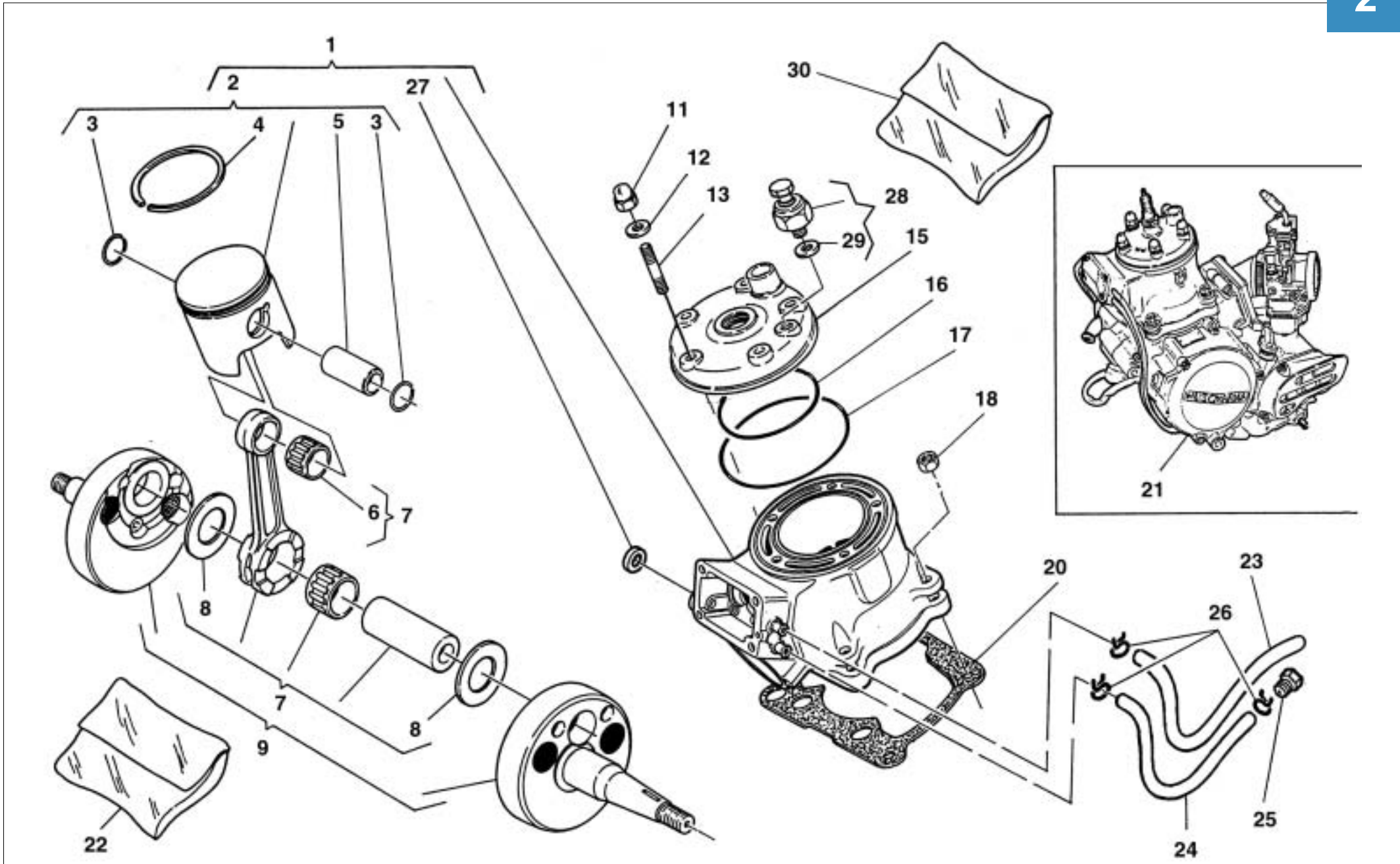

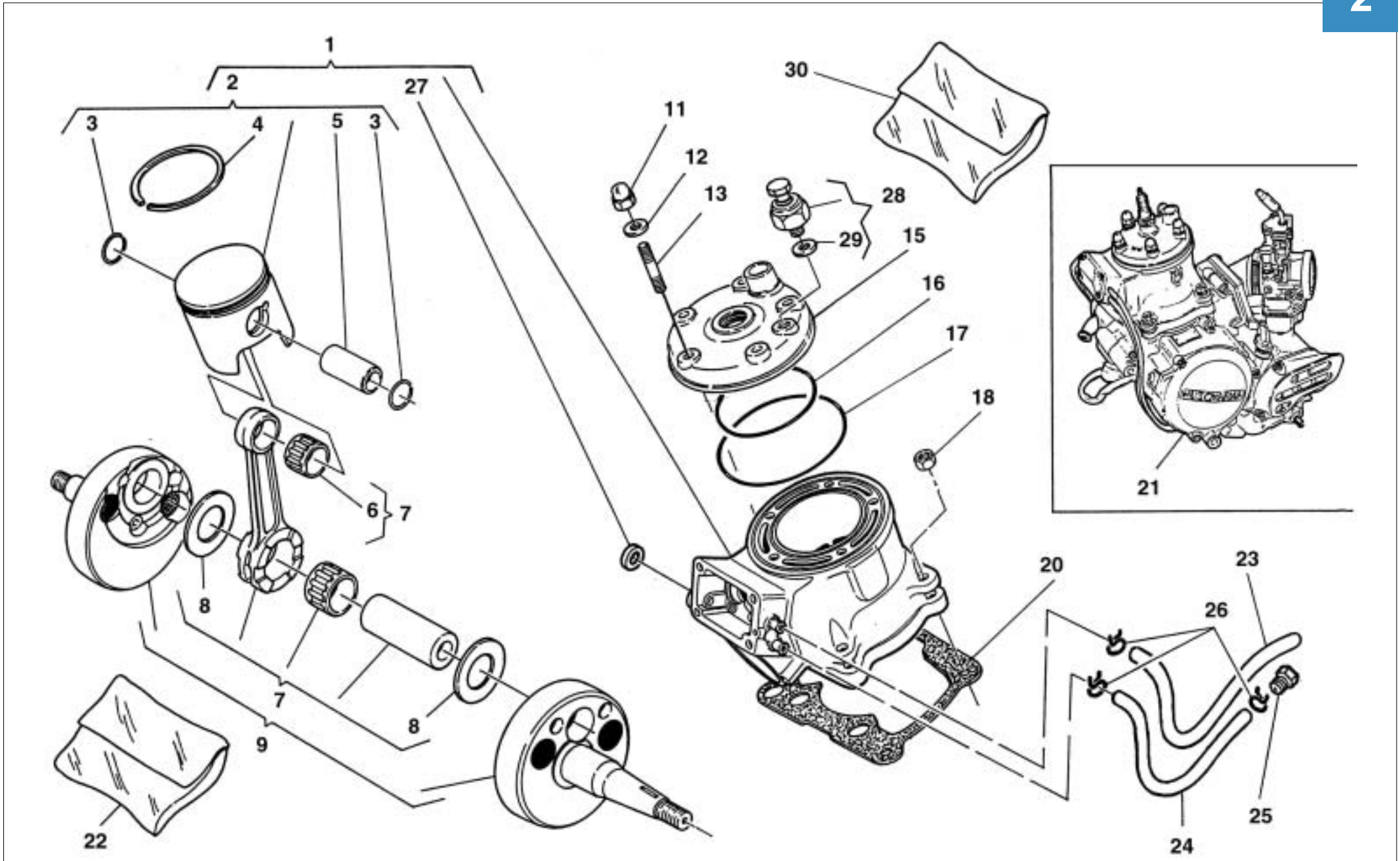

La sottoriportata tabella elenca i possibili accoppiamenti che consentono di ottenere il corretto gioco radiale di 0,002÷0,010 mm

The table hereunder shows the possible coupling which allow to obtain a radial clearance of 0,002÷0,010 mm

Le tableau ci-dessous indique tous les couplages possibles permettant d'obtenir le jeu radial exact de 0,002÷0,010 mm

Die folgende Tabelle gibt die möglichen Verbindungen an für das genaue Radialspiel von 0,002÷0,010 mm

La tabla que se da a continuación lista los acoplamientos posibles que permiten obtener el juego radial correcto de 0,002÷0,010 mm

C: rod selection colour

C: colore di selezione biella

C: couleur de sélection bielle

C: Wahlfarbe der Pleuelstange

C: color de selección biela

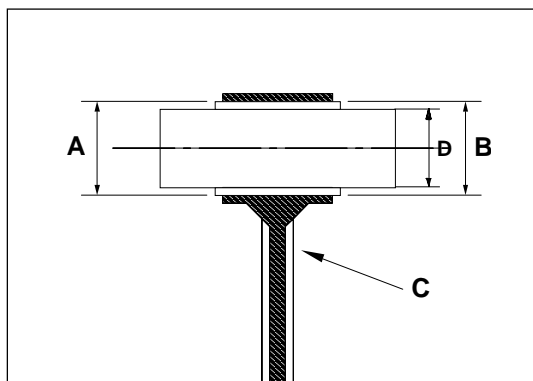

Colore di selezione foro «A» piede di biella (mm) Hole selection colour «A» connecting rod small end (mm) Couleur de sélection trou «A» pied de bielle (mm) Wahlfarbe der Bohrung «A» Pleuelstangenkopf (mm) Color de selección «A» pie de biela (mm)	Selezione gabbia a rullini «B» Cage selection «B» Sélection cage à rouleaux «B» Wahlnadelkäfig «B» Selección jaula de agujas «B»	Colore di selezione diametro «D» spinotto (mm) Diameter selection colour «D» Gudgeon (mm) Couleur de sélection diamètre «D» axe (mm) Wahlfarbe der Durchmesser «D» Bolzen (mm) Color de selección diámetro «D» perno (mm)
Rosso - Red - Rouge - Rot - Rojo 19,002÷19,004	0 ÷ -2	Nero - Black - Noir - Schwarz - Negro 15,000÷14,998
Bianco - White - Blanc - Weiss - Blanco 18,998÷19,000	-1 ÷ -3	Bianco - White - Blanc - Weiss - Blanco 14,998÷14,996
Nero - Black - Noir - Schwarz - Negro 19,000÷19,002	0 ÷ -2	Bianco - White - Blanc - Weiss - Blanc 14,998÷14,996
Nero - Black - Noir - Schwarz - Negro 19,000÷19,002	-1 ÷ -3	Nero - Black - Noir - Schwarz - Negro 15,000÷14,998

Qualora, in sede di revisione del motore, si dovesse riscontrare un gioco radiale superiore al limite ammesso di 0,015 mm e non fosse più visibile il contrassegno del colore sullo stelo della biella, rilevare il diametro «A» del piede di biella e, in base a questo, montare la gabbietta appropriata.

When overhauling, should a radial clearance greater than the consented limit of 0.015 mm be noticed and the colour mark under the connecting rod small end is no more visible, collect the connecting rod small end «A» diameter and assemble the right cage according to it.

NOTA: Nel richiedere la gabbia a rullini, specificare la selezione.

NOTE: When requesting the cage, specify the selection.

Si en révisonnant le moteur on trouve un jeu radial supérieur à la limite admise de 0,015 mm et le marque de la couleur n'est plus visible sur la tige de bielle, enregistrer le diamètre «A» du pied de bielle et assembler la cage exacte selon ce diamètre.

NOTA: En demandant la cage à rouleaux, spécifier la sélection.

Falls bei Motorprüfung das Radialspiel über das zugelassene Mass von 0,015 mm sein sollte und das Farbkennzeichen an der Pleuelstange nicht mehr sichtbar ist, wird der «A»-Durchmesser des Pleuelstangenkopfes gemessen und aufgrund dessen der geeignete Käfig montiert..

BEMERKUNG: Bei Anfrage den genauen Wahlnadelkäfig angeben.

En el caso que, cuando inspeccione el motor, encuentre un juego radial superior al límite admitido de 0,015 mm y no resultara más visible la señalización del color en el vástago de la biela, registre el diámetro «A» del piede biela y, sobre la base de este dato, monte la jaula adecuada.

NOTA: cuando pida la jaula de agujas, especifique la selección.

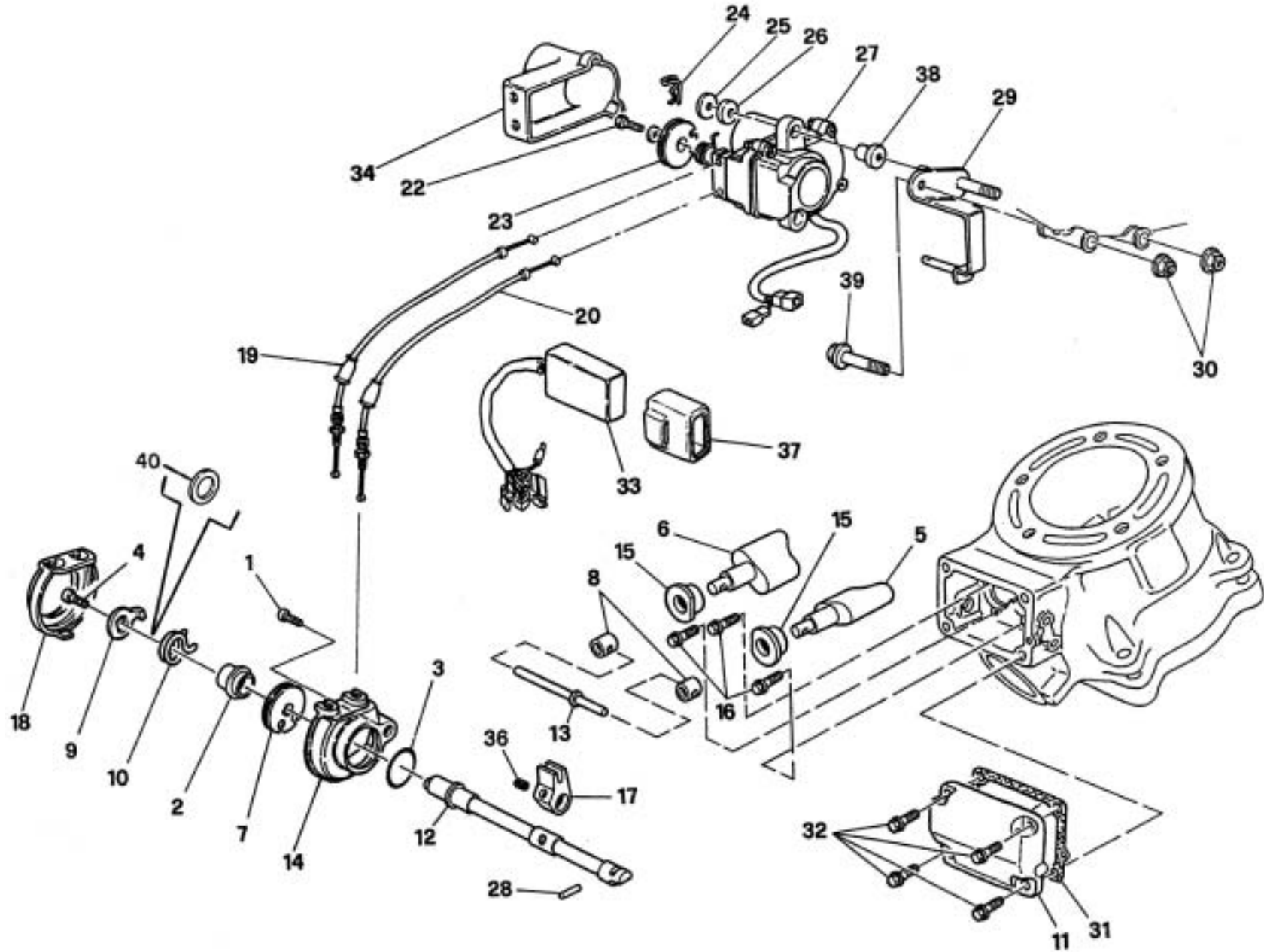

Note Notes Marke Notas	Pos. No. N. Index Pos.	N. Cod. Code No. Nr. Code Code Nr N. Cod.	Q.tà Q.ty Q.te M.ge C.ad	DENOMINAZIONE	NAME	DESIGNATION	BESHREIBUNG	DENOMINACION	Validità Validity Validité Gültig Validez
	1	60N0 17330	1	Vite	Screw	Vis	Schraube	Tornillo	
	2	8000 83114	1	Mozzo	Hub	Moyeau	Radnabe	Cubo	
	3	8000 19789	1	Anello OR	OR ring	Bague OR	Ring OR	Anillo OR	
	4	8A00 67997	1	Vite	Screw	Vis	Schraube	Tornillo	
	5	8000 83123	1	Valvola di scarico Sx	L.H. exhaust valve	Soupape d'echapement G.	Auslass-ventil Linke	Válvula de escape iz.	
	6	8000 83122	1	Valvola di scarico Dx	R.H. exhaust valve	Soupape d'echapement D.	Auslass-ventil Rechte	Válvula de escape der.	
	7	8000 83108	1	Carrucola	Pulley	Poulie	Führungrolle	Bombadora	
	8	8000 99755	2	Bussola	Bush	Douille	Buchse	Manguito	
	9	8000 83110	1	Leva	Lever	Levier	Hebel	Palanca	
	10	8000 83109	1	Molla	Spring	Ressort	Feder	Resorte	
	11	8000 83090	1	Coperchio	Cover	Couvercle	Deckel	Tapa	
	12	8000 83116	1	Albero com. valvole	Valve shaft	Arbre de comande soupape	Ventilwelle	Eje mando válvula	
	13	8000 83113	1	Perno di trascinamento	Pin	Pivot	Bolzen	Pérno	
	14	8000 83077	1	Basetta	Side	Base	Platte	Placa	
	15	8000 83118	2	Fermo corsa	Retainer	Arrêt	Klammer	Abrazadera	
	16	8E00 67997	3	Vite	Screw	Vis	Schraube	Tornillo	
	17	8000 83119	1	Biscottino leva	Lever	Levier	Hebel	Palanca	
	18	8000 83078	1	Coperchio	Cover	Couvercle	Deckel	Tapa	
	19	8E00 58865	1	Trasmissione	Wire	Trasmission	Kabel	Trasmission	
	20	8D00 58865	1	Trasmissione	Wire	Trasmission	Kabel	Trasmission	
	22	8000 67997	1	Vite	Screw	Vis	Schraube	Tornillo	
	23	8000 54895	1	Carrucola	Pulley	Poulie	Führungrolle	Bombadora	
	24	8000 62705	2	Molletta	Spring	Ressort	Feder	Resorte	
	25	8000 39260	2	Rosetta	Washer	Rondelle	Scheibe	Arandela	
	26	8000 62390	2	Rosetta	Washer	Rondelle	Scheibe	Arandela	
	27	8000 59034	1	Attuatore	Actuator	Actionner	Ttieeb	Actuador	
	28	8000 47773	1	Rullino per valvola	Needle	Aiguille	Rolle	Rodillo	
	29	8000 75806	1	Supporto	Bearing	Support	Halter	Soporte	
	30	8000 43928	2	Dado frenato	Nut	Ecrou	Mutter	Tuerca	
	31	8000 83049	1	Guarnizione	Gasket	Garniture	Dichtung	Junta	
	32	8A00 67997	4	Vite	Screw	Vis	Schraube	Tornillo	
E	33	8000 86785	1	Controllore apertura valvola	Valve opening control	Controle d'ouverture clapet	Kontrolle ventil oefnung	Control apertura valvula	
	33	8000 94466	1	Controllore apertura valvola	Valve opening control	Controle d'ouverture clapet	Kontrolle ventil oefnung	Control apertura valvula	

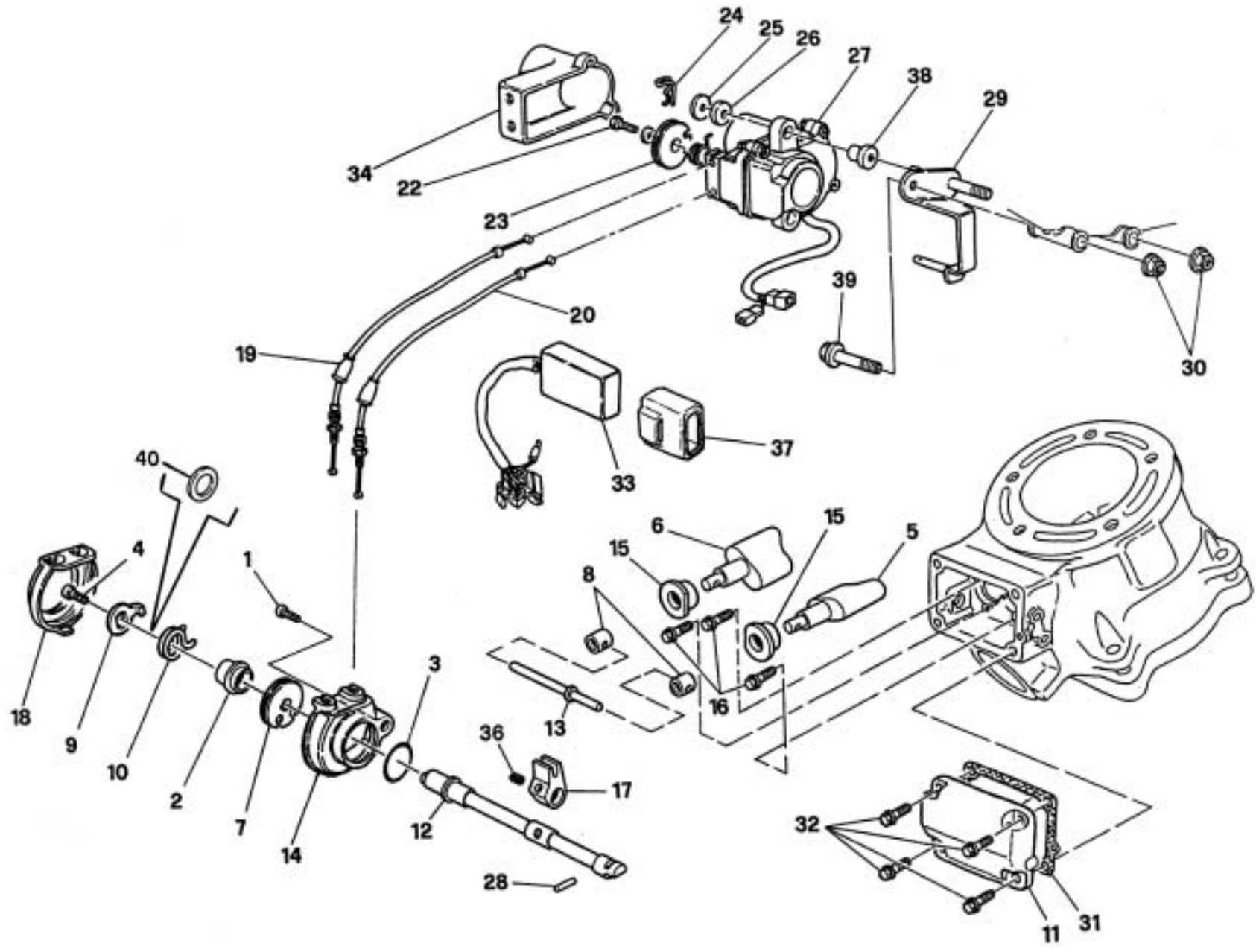

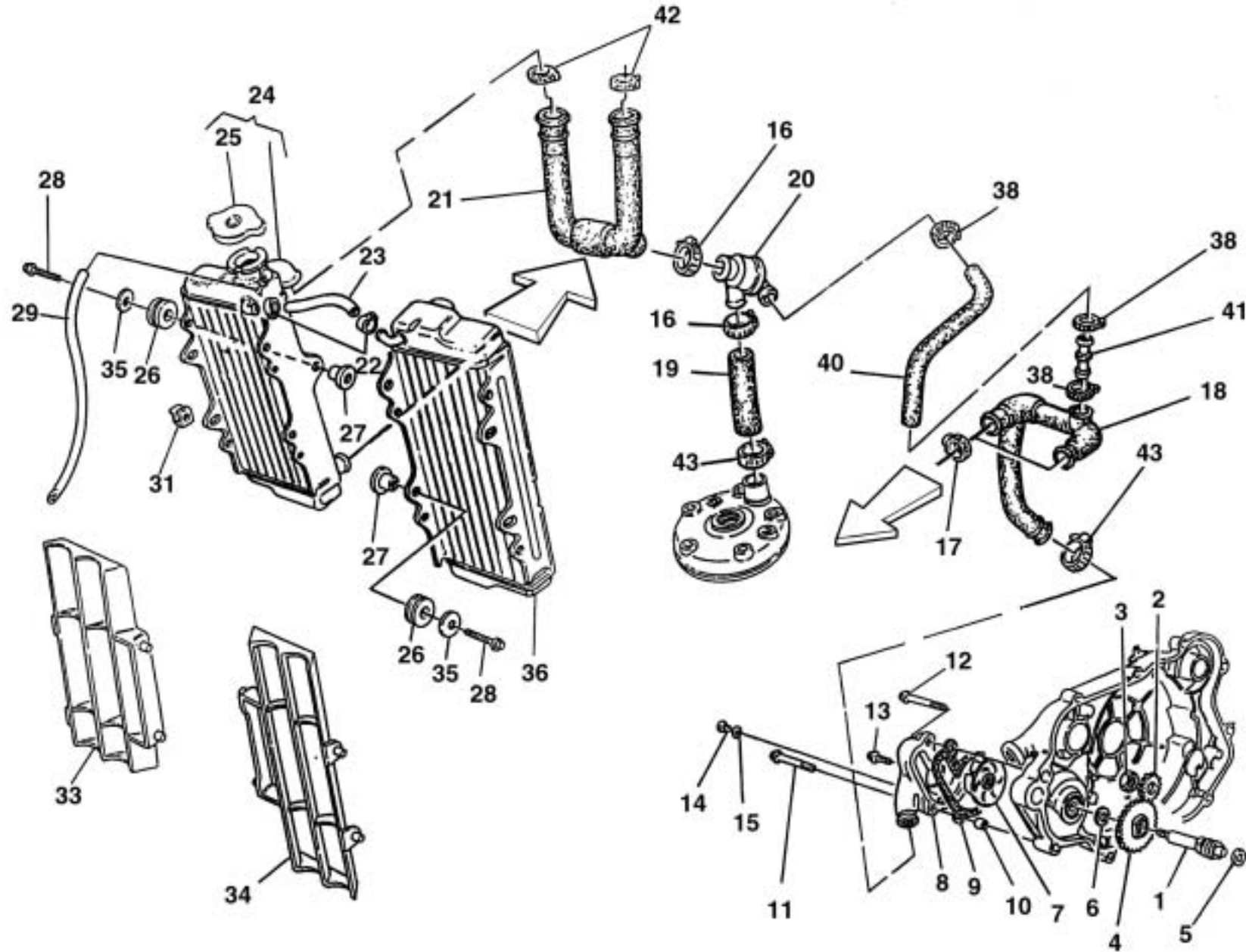

Note Notes Marke Notas	Pos. No. N. Index Pos.	N. Cod. Code No. Nr. Code Code Nr N. Cod.	Q.tà Q.ty Q.te M.ge C.ad	DENOMINAZIONE	NAME	DESIGNATION	BESHREIBUNG	DENOMINACION	Validità Validity Validité Gültig Validez
	1	8000 79561	1	Alber.com.pompa acqua	Shaft	Arbre	Welle	Eje	
	2	8000 65923	1	Pignone (Z16)	Pinion (Z16)	Pignon (Z16)	Ritzel (Z16)	Engranaje (Z16)	
	3	8A00 04883	1	Dado	Nut	Ecrou	Mutter	Tuerca	
	4	8000 65935	1	Ingranaggio pompa (Z32)	Pinion (Z32)	Pignon (Z32)	Ritzel (Z32)	Engranaje (Z32)	
	5	8E00 34292	1	Rosetta	Washer	Rondelle	Scheibe	Arandela	
	6	8F00 28960	1	Rosetta	Washer	Rondelle	Scheibe	Arandela	
	7	8000 68277	1	Girante	Rotor	Couronne	Laufrad	Rotor	
	8	80B0 83024	1	Corpo pompa	Pump body	Corps pompe	Pumpenkoper	Corpo bomba	
	9	8000 65922	1	Guarnizione	Gasket	Garniture	Dichtung	Junta	
	10	1617 95501	2	Bussola	Bushing	Douille	Buchse	Manguito	
	11	8000 62731	1	Vite	Screw	Vis	Schraube	Tornilo	
	12	8B00 67545	1	Vite	Screw	Vis	Schraube	Tornilo	
	13	8000 62728	1	Vite	Screw	Vis	Schraube	Tornilo	
	14	8S00 67545	1	Vite	Screw	Vis	Schraube	Tornilo	
	15	8000 03271	1	Rosetta	Washer	Rondelle	Scheibe	Arandela	
	16	8B00 99475	2	Fascetta	Clamp	Collier	Schelle	Banda	
	17	8000 46881	2	Fascetta	Clamp	Collier	Schelle	Banda	
	18	8000 94131	1	Tubo radiatori pompa	Pipe	Tuyau	Rohr	Tubo	
	19	8000 94682	1	Tubo testa-termostato	Pipe	Tuyau	Rohr	Tubo	
	20	8000 75984	1	Termostato	Thermo-switch	Thermostate	Thermostat	Termostato	
	21	8000 94681	1	Tubo termostato-radiatori	Pipe	Tuyau	Rohr	Tubo	
	22	8000 56462	2	Fascetta	Clamp	Collier	Schelle	Banda	
	23	8C00 43716	1	Tubo raccordo radiatori	Pipe	Tuyau	Rohr	Tubo	
	24	8000 92216	1	Radiatore destro	Right radiator	Radiateur droit	Rechter Kühler .	Radiador derecho	
	25	8000 79077	1	Tappo radiatore	Plug	Bouchon	Verschluss	Tapón	
	26	8000 59803	6	Gommino	Rubber pad	Pièce caoutchouc	Gummistück	Junta de goma	
	27	8D00 59802	6	Bussola	Bushing	Douille	Buchse	Manguito	
	28	8000 62729	6	Vite	Screw	Vis	Schraube	Tornilo	
	29	8B00 43715	1	Tubo sfiato	Pipe	Tuyau	Rohr	Tubo	
	31	8000 60873	4	Dado	Nut	Ecrou	Mutter	Tuerca	
	33	8000 A0872	1	Griglia destra	R. grid	Grille D.	R. Rost	Parrilla Der.	
	34	8000 A0872	1	Griglia sinistra	L. grid	Grille G.	L. Rost	Parrilla Izq.	
	35	8000 59801	6	Rosetta	Washer	Rondelle	Scheibe	Arandela	

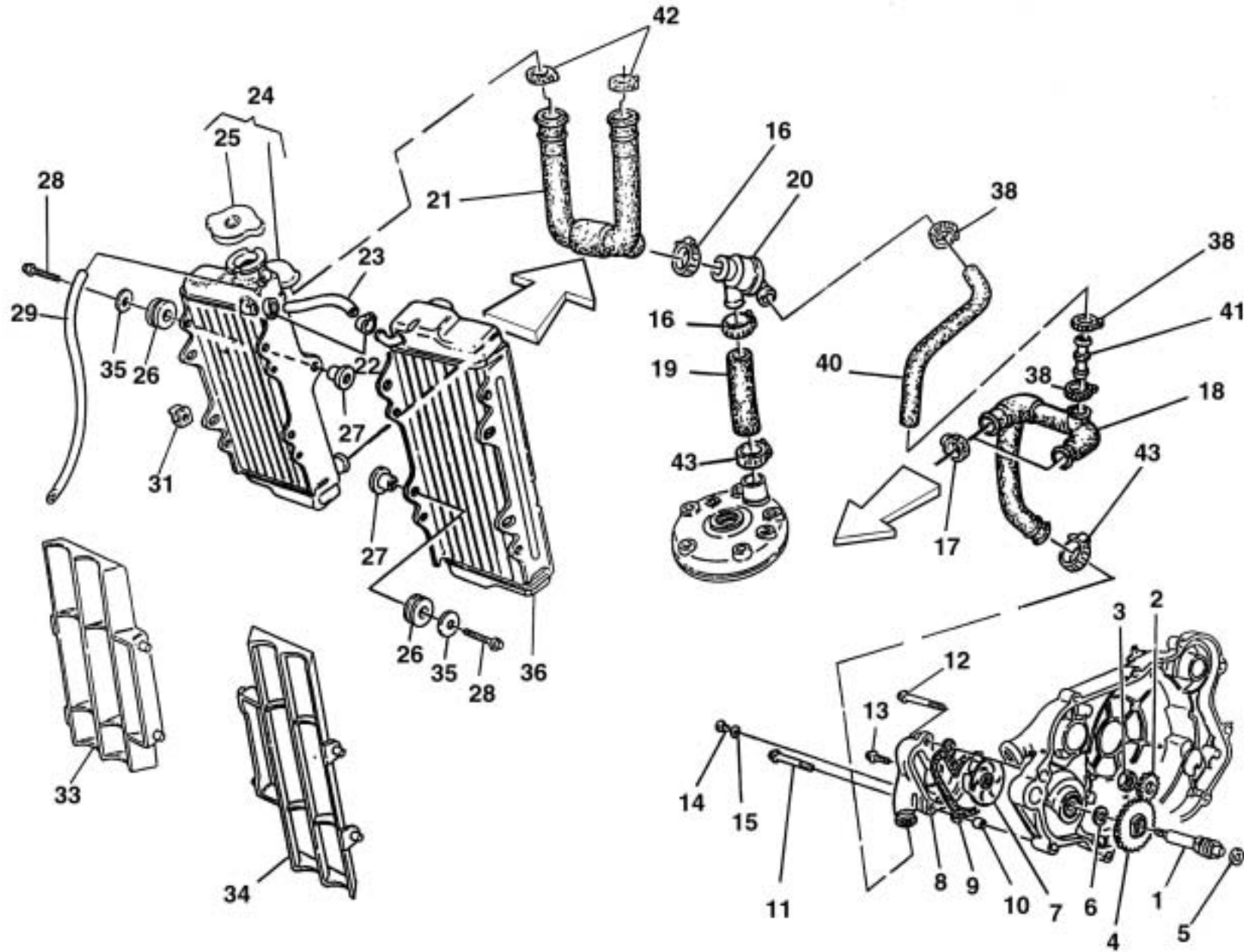

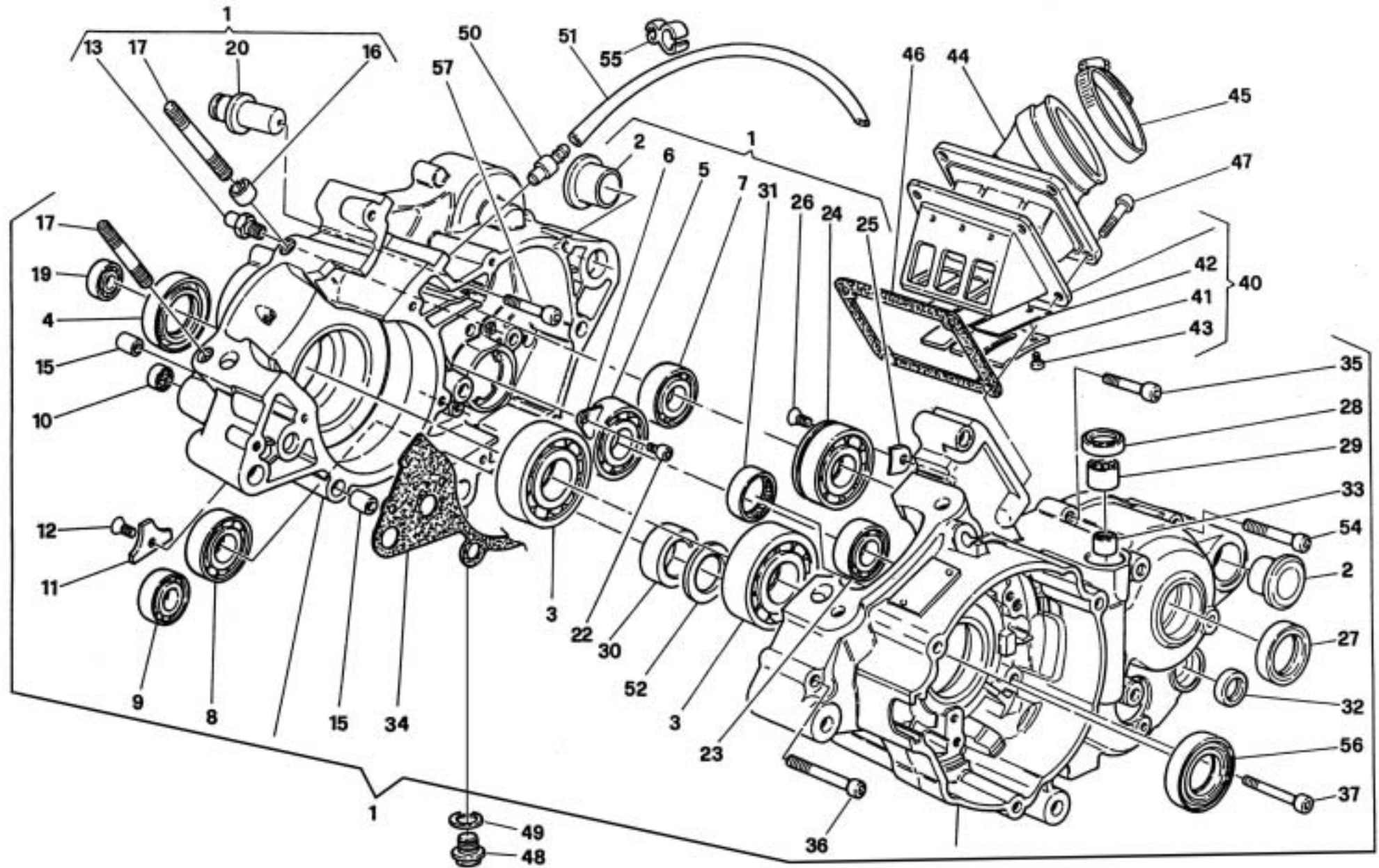

Note Notes Marke Notas	Pos. No. N. Index Pos.	N. Cod. Code No. Nr. Code Code Nr N. Cod.	Q.tà Q.ty Q.te M.ge C.ad	DENOMINAZIONE	NAME	DESIGNATION	BESHREIBUNG	DENOMINACION	Validità Validity Validité Gültig Validez
	1	8000 A1103	1	Carter accoppiati compl.	Crankcase assy	Carters assemblé compl.	Kürbelgehäuse kpl.	Carter motor compl.	
	2	8A00 71154	2	Bussola	Bushing	Douille	Büshse	Manguito	
	3	8000 88828	2	Cuscinetto (ø22xø56x16 mm)	Ball bearing(ø22xø56x16mm)	Roulement (ø22xø56x16 mm)	Lager (ø22xø56x16 mm)	Cojienete (ø22xø56x16 mm)	
	4	8000 83590	1	Anello di tenuta (ø32xø40x7,5 mm)	Seal ring (ø32xø40x7,5 mm)	Bague d'étanchéité (ø32xø40x7,5 mm)	Dichtungsring (ø32xø40x7,5 mm)	Anillo de retención (ø32xø40x7,5 mm)	
	5	8000 43382	1	Cuscinetto (ø17xø47x14 mm)	Bearing (ø17xø47x14 mm)	Roulement (ø17xø47x14 mm)	Lager (ø17xø47x14 mm)	Cojienete (ø17xø47x14 mm)	
	6	8000 53324	1	Piastrina	Plate	Plaquette	Plättchen	Placa	
	7	8000 21939	1	Cuscinetto (ø15xø35x11 mm)	Bearing (ø15xø35x11 mm)	Roulement (ø15xø35x11 mm)	Lager (ø15xø35x11 mm)	Cojienete (ø15xø35x11 mm)	
	8	8A00 53248	1	Cuscinetto	Bearing	Roulement	Lager	Cojienete	
	9	8A00 54164	1	Cuscinetto	Bearing	Roulement	Lager	Cojienete	
	10	8000 47678	1	Cuscinetto a rullini (ø8xø12x8 mm)	Needle bearing (ø8xø12x8 mm)	Roulement à aiguilles (ø8xø12x8 mm)	Nadelkafig (ø8xø12x8 mm)	Cojinete (ø8xø12x8 mm)	
	11	8000 66952	1	Piastrina	Plate	Plaquette	Plättchen	Placa	
	12	8000 42643	1	Vite	Screw	Vis	Schraube	Tornillo	
	13	8A00 66953	1	Perno	Pin	Pivot	Bolzen	Perno	
	15	8000 07719	4	Bussola	Bushing	Douille	Büshse	Manguito	
	16	8000 99767	2	Spina elastica	Pin	Goupille	Stift	Clavija	
	17	8000 74836	4	Prigioniero (M8 x 51 mm)	Stud bolt (M8 x 51 mm)	Prisonnier (M8 x 51 mm)	Stiftschraube (M8 x 51 mm)	Prisionero (M8 x 51 mm)	
	19	8000 06597	1	Cuscinetto (ø8xø22x7 mm)	Bearing (ø8xø22x7 mm)	Roulement (ø8xø22x7 mm)	Lager (ø8xø22x7 mm)	Cojienete (ø8xø22x7 mm)	
	20	8000 77841	1	Perno	Pin	Pivot	Bolzen	Perno	
	22	8000 67997	1	Vite	Screw	Vis	Schraube	Tornillo	
	23	8000 21939	1	Cuscinetto (ø15xø35x11 mm)	Bearing (ø15xø35x11 mm)	Roulement (ø15xø35x11 mm)	Lager (ø15xø35x11 mm)	Cojienete (ø15xø35x11 mm)	
	24	8000 51745	1	Cuscinetto (ø20xø52x15 mm)	Bearing (ø20xø52x15 mm)	Roulement (ø20xø52x15 mm)	Lager (ø20xø52x15 mm)	Cojienete (ø20xø52x15 mm)	
	25	8000 51746	1	Piastrina	Plate	Plaquette	Plättchen	Placa	
	26	8000 42643	3	Vite	Screw	Vis	Schraube	Tornillo	
	27	8000 36357	2	Anello di tenuta (ø26xø35x7 mm)	Seal ring ((ø26xø35x7 mm)	Bague d'étanchéité (ø26xø35x7 mm)	Dichtungsring (ø26xø35x7mm)	Anillo de retención (ø26xø35x7 mm)	
	28	8000 48856	2	Anello di tenuta (ø13xø20x4 mm)	Seal ring (ø13xø20x4 mm)	Bague d'étanchéité (ø13xø20x4 mm)	Dichtungsring (ø13xø20x4mm)	Anillo de retención (ø13xø20x4 mm)	
	29	8000 49016	1	Boccola (ø13xø19x12 mm)	Bushing (ø13xø19x12 mm)	Douille (ø13xø19x12 mm)	Büchse (ø13xø19x12 mm)	Manguito (ø13xø19x12 mm)	
	30	8000 54427	1	Rullo di contrasto	Roller	Aiguille	Rolle	Rodillo	
	31	8000 62200	1	Cuscinetto a rullini (ø24xø30x7,5 mm)	Needle bearing (ø24xø30x7,5 mm)	Roulement à aiguilles (ø24xø30x7,5 mm)	Nadelkafig (ø24xø30x7,5 mm)	Cojienete (ø24xø30x7,5 mm)	

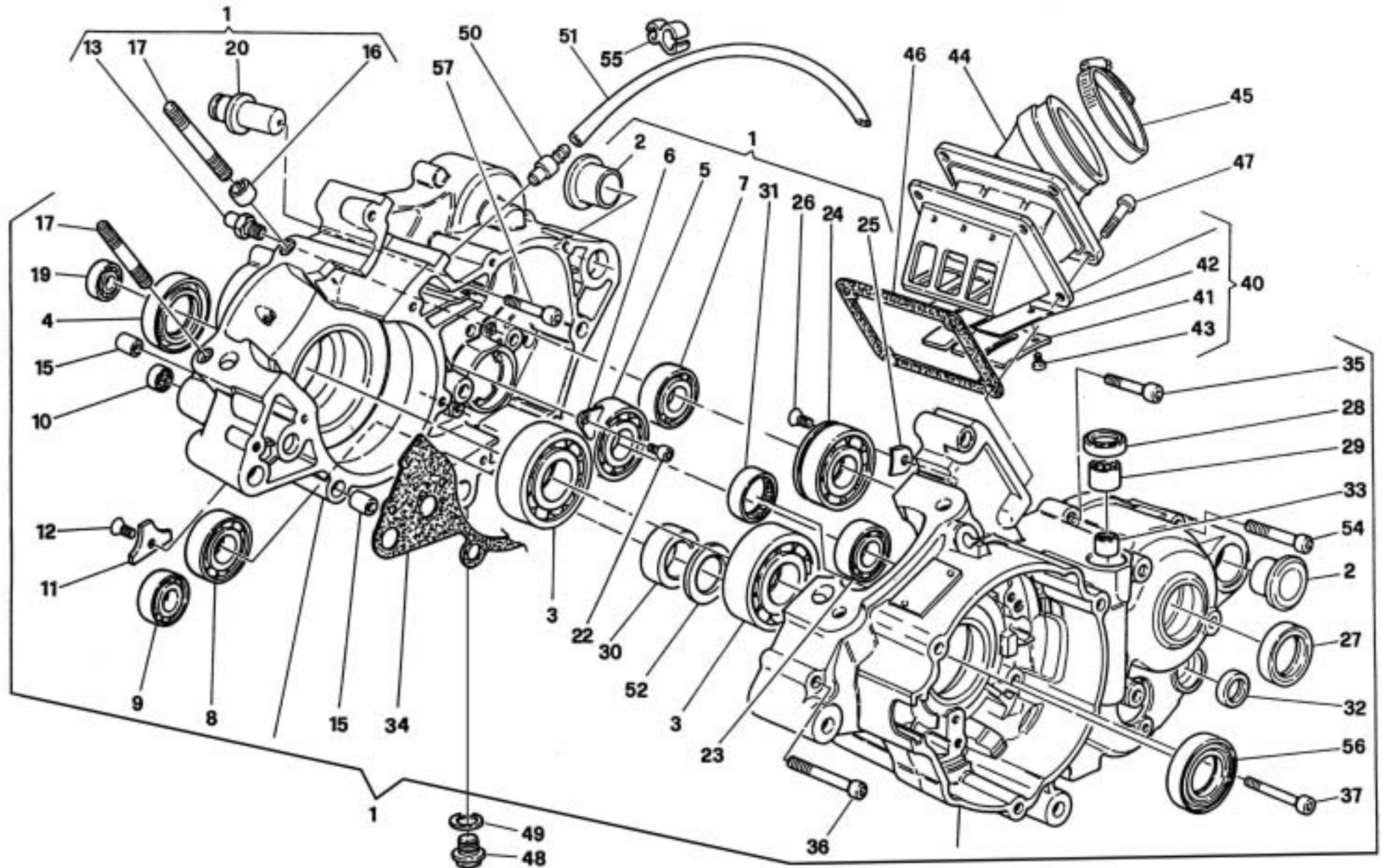

Note Notes Marke Notas	Pos. No. N. Index Pos.	N. Cod. Code No. Nr. Code Code Nr N. Cod.	Q.tà Q.ty Q.te M.ge C.ad	DENOMINAZIONE	NAME	DESIGNATION	BESHREIBUNG	DENOMINACION	Validità Validity Validité Gültig Validez
	32	8000 34451	1	Anello di tenuta ($\varnothing 12 \times \varnothing 19 \times 5$ mm)	Seal ring ($\varnothing 12 \times \varnothing 19 \times 5$ mm)	Bague d'étanchéité ($\varnothing 12 \times \varnothing 19 \times 5$ mm)	Dichtungsring ($\varnothing 12 \times \varnothing 19 \times 5$ mm)	Anillo de retención ($\varnothing 12 \times \varnothing 19 \times 5$ mm)	
	33	8000 47678	1	Cuscinetto a rullini ($\varnothing 8 \times \varnothing 12 \times 8$ mm)	Needle bearing ($\varnothing 8 \times \varnothing 12 \times 8$ mm)	Roulement à aiguilles ($\varnothing 8 \times \varnothing 12 \times 8$ mm)	Nadelkafig ($\varnothing 8 \times \varnothing 12 \times 8$ mm)	Cojienete ($\varnothing 8 \times \varnothing 12 \times 8$ mm)	
	34	8000 72889	1	Guarnizione	Gasket	Garniture	Dichtung	Junta	
	35	60N1 02512	5	Vite (M6 x 35 mm)	Screw (M6 x 35 mm)	Vis (M6 x 35 mm)	Schraube (M6 x 35 mm)	Tornillo (M6 x 35 mm)	
	36	60N1 02515	2	Vite (M6 x 50 mm)	Screw (M6 x 50 mm)	Vis (M6 x 50 mm)	Schraube (M6 x 50 mm)	Tornillo (M6 x 50 mm)	
	37	60N1 02514	3	Vite (M6 x 45 mm)	Screw (M6 x 45 mm)	Vis (M6 x 45 mm)	Schraube (M6 x 45 mm)	Tornillo (M6 x 45 mm)	
	40	8000 76074	1	Valvola d'aspirazione compl.	Inlet valve	Soupape admission	Einlass-Ventil	Valvula aspiracion	
	41	8000 76075	2	Piastrina fermo lamella	Plate	Plaquette	Plättchen	Placa	
	42	8000 76076	2	Lamella	Plate	Plaquette	Plättchen	Placa	
	43	8000 61102	6	Vite	Screw	Vis	Schraube	Tornillo	
	44	8000 87813	1	Raccordo carburatore	Union	Raccord	Anschluss	Empalme	
	45	8000 27521	1	Fascetta	Clamp	Collier	Schelle	Banda	
	46	8000 83043	1	Guarnizione	Gasket	Garniture	Dichtung	Junta	
	47	8000 98213	4	Vite	Screw	Vis	Schraube	Tornillo	
	48	8000 75415	1	Tappo scarico olio	Oil drain plug	Bouchon vidange huile	Stöpsel f. ölablass	Tapón purga aceite	
	49	62N0 15678	1	Rosetta di tenuta	Washer	Rondelle	Scheibe	Arandela	
	50	8000 76262	1	Raccordo sfiato	Union	Raccord	Anschluss	Empalme	
	51	8000 41750	1	Tubetto	Pipe	Tuyau	Rohr	Tubo	
	52	8E00 32069	1	Rosetta	Washer	Rondelle	Scheibe	Arandela	
	54	60N1 02518	2	Vite (M6 x 65 mm)	Screw (M6 x 65 mm)	Vis (M6 x 65 mm)	Schraube (M6 x 65 mm)	Tornillo (M6 x 65 mm)	
	55	8000 78727	1	Molletta ritegno tubi	Guide ring	Bague de guide	Rohring	Guja cable	
	56	8000 92896	1	Anello di tenuta ($\varnothing 20 \times \varnothing 40 \times 7$ mm)	Seal ring ($\varnothing 20 \times \varnothing 40 \times 7$ mm)	Bague d'étan. ($\varnothing 20 \times \varnothing 40 \times 7$ mm)	Dichtungsring ($\varnothing 20 \times \varnothing 40 \times 7$ mm)	Anillo de reten. ($\varnothing 20 \times \varnothing 40 \times 7$ mm)	
	57	60N1 07335	1	Vite	Screw	Vis	Schraube	Tornillo	

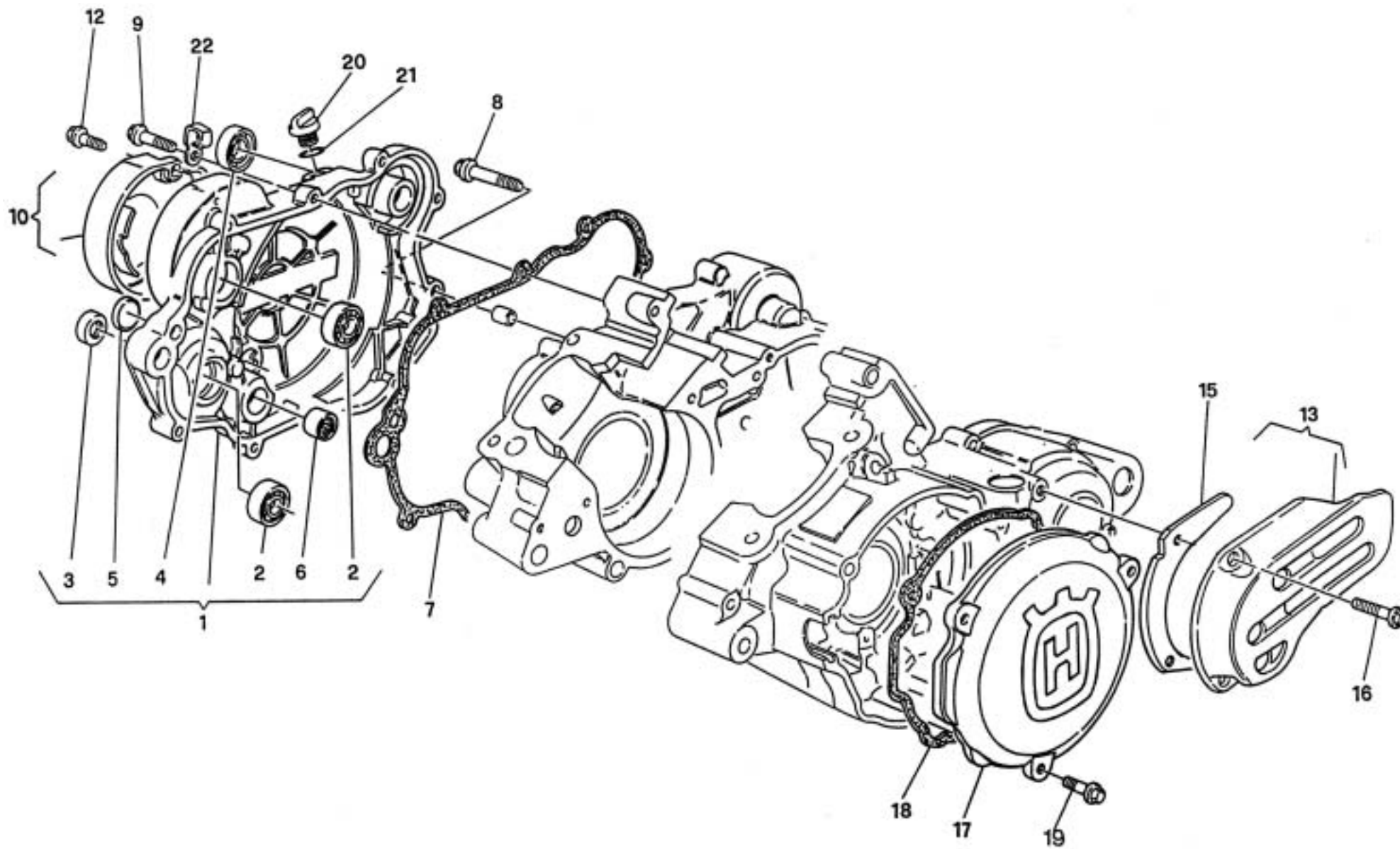

Note Notes Marke Notas	Pos. No. N. Index Pos.	N. Cod. Code No. Nr. Code Code Nr N. Cod.	Q.tà Q.ty Q.te M.ge C.ad	DENOMINAZIONE	NAME	DESIGNATION	BESHREIBUNG	DENOMINACION	Validità Validity Validité Gültig Validez
	1	8000 74414	1	Coperchio carter DX	R.H. Cover	Couvercle carter D.	Deckel R.	Tapa carter D.	
	2	8000 28959	2	Cuscinetto (ø10xø26x8 mm)	Bearing (ø10xø26x8 mm)	Roulement (ø10xø26x8 mm)	Lager (ø10xø26x8 mm)	Cojinete (ø10xø26x8 mm)	
	3	8000 68278	1	Anello CORCOS (ø8,6xø18x8 mm)	CORCOS ring (ø8,6xø18x8 mm)	Bague CORCOS (ø8,6xø18x8 mm)	Ring CORCOS (ø8,6xø18x8 mm)	Anillo CORCOS (ø8,6xø18x8 mm)	
	4	8000 36653	1	Anello CORCOS (ø16xø25x4 mm)	CORCOS ring (ø16xø25x4 mm)	Bague CORCOS (ø16xø25x4 mm)	Ring CORCOS (ø16xø25x4 mm)	Anillo CORCOS (ø16xø25x4 mm)	
	5	8000 53340	1	Spia livello olio	Oil inspection cap	Bouchon controle huile	Oeelstandkontrolle	Mirilla nivel aceite	
	6	8000 53322	1	Cuscinetto (ø12xø19x12 mm)	Bearing (ø12xø19x12 mm)	Roulement (ø12xø19x12 mm)	Lager (ø12xø19x12 mm)	Cojinete (ø12xø19x12 mm)	
	7	8000 66968	1	Guarnizione	Gasket	Garnitue	Dichtung	Junta	
	8	8A00 67545	1	Vite (M6 x 35 mm)	Screw (M6 x 35 mm)	Vis (M6 x 35 mm)	Schraube (M6 x 35 mm)	Tornillo (M6 x 35 mm)	
	9	8000 62729	7	Vite (M6 x 25 mm)	Screw (M6 x 25 mm)	Vis (M6 x 25 mm)	Schraube (M6 x 25 mm)	Tornillo (M6 x 25 mm)	
	10	8000 73021	1	Coperchio pompa olio	Cover	Couvercle	Deckel	Tapa	
	12	8A00 66525	2	Vite	Screw	Vis	Schraube	Tornillo	
	13	8000 66973	1	Coperchio pignone	Cover	Couvercle	Deckel	Tapa	
	15	8000 74758	1	Piastrina	Plate	Plaque	Platte	Placa	
	16	8000 62728	2	Vite	Screw	Vis	Schraube	Tornillo	
	17	8AC0 66947	1	Coperchio volano	Cover	Couvercle	Deckel	Tapa	
	18	8000 66972	1	Guarnizione	Gasket	Garnitue	Dichtung	Junta	
	19	8000 62728	3	Vite	Screw	Vis	Schraube	Tornillo	
	20	8000 54141	1	Tappo per carico olio	Plug	Bouchon	Verschluss	Tapón intruduecion aceite	
	21	8000 01199	1	Anello OR	OR ring	Bague OR	Ring OR	Anillo OR	
	22	8000 35370	2	Piastrina	Plate	Plaque	Platte	Placa	

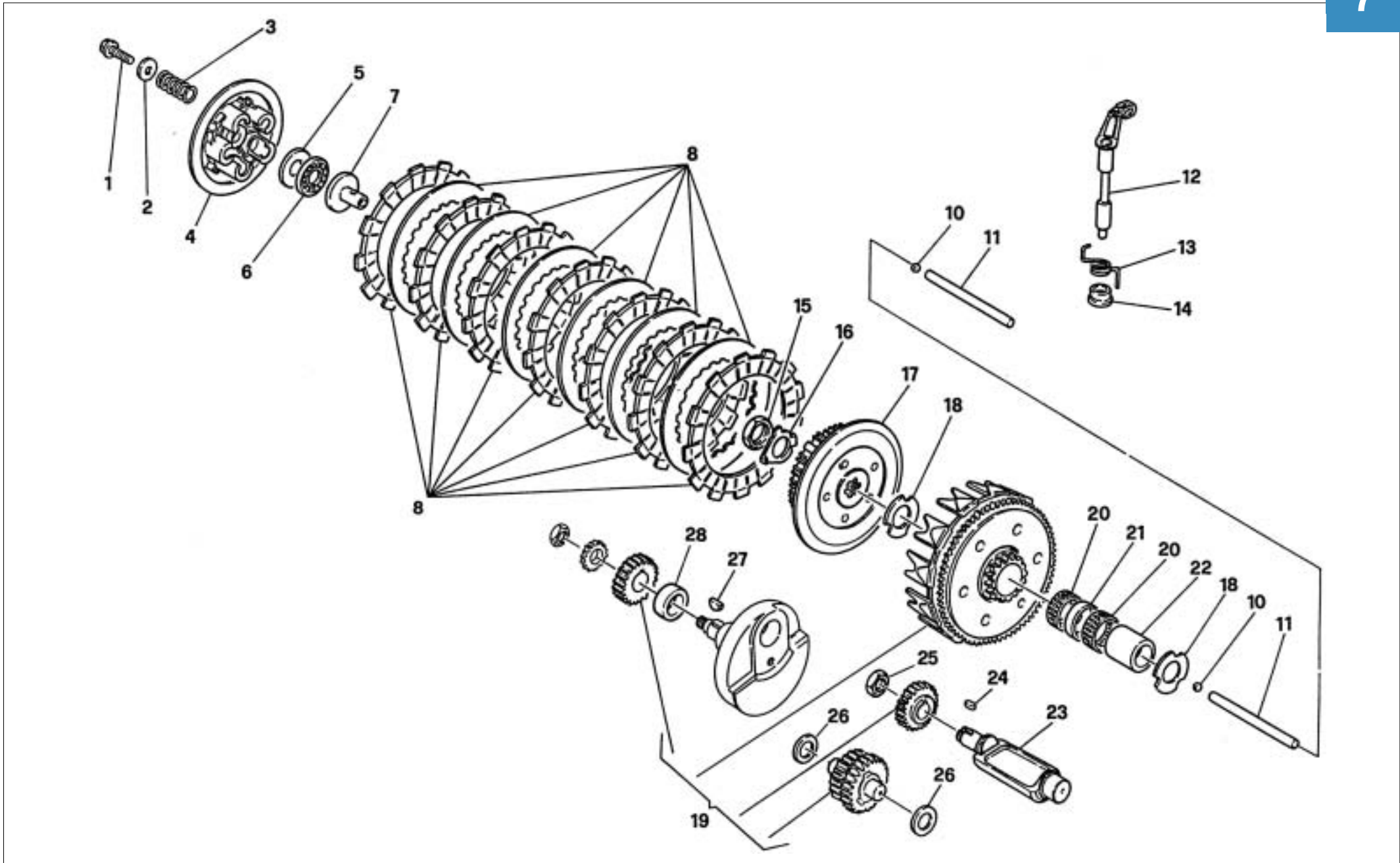

Note Notes Marke Notas	Pos. No. N. Index Pos.	N. Cod. Code No. Nr. Code Code Nr N. Cod.	Q.tà Q.ty Q.te M.ge C.ad	DENOMINAZIONE	NAME	DESIGNATION	BESHREIBUNG	DENOMINACION	Validità Validity Validité Gültig Validez
	1	8000 62728	5	Vite	Screw	Vis	Schraube	Tornillo	
	2	8000 48814	5	Rosetta	Washer	Rondelle	Scheibe	Arandela	
	3	8000 75390	5	Molla	Spring	Ressort	Feder	Resorte	
A	3	8000 83085	5	Molla	Spring	Ressort	Feder	Resorte	
	4	8000 70467	1	Spingidisco	Pressure plate	Pousse disque	Scheibendrucker	Empuia disco	
	5	8000 70551	1	Ralla	Washer	Rondelle	Scheibe	Arandela	
	6	8000 70550	1	Cuscinetto a rullini	Needle bearing	Roulement à aiguilles	Nadelkäfig	Cojinete	
	7	8000 70549	1	Piattello	Disc	Disque	Scheibe	Disco	
	8	8000 88822	1	Ass. gruppo frizione	Clutch group assy	Groupe embrayage compl.	Kupplungsgruppe Kpl.	Grupo embrague compl.	
A	8	8000 88823	1	Ass. gruppo frizione	Clutch group assy	Groupe embrayage compl.	Kupplungsgruppe Kpl.	Grupo embrague compl.	
	10	6BN0 21506	2	Sfera	Ball	Bille	Kugel	Esfera	
	11	8000 70309	2	Astina	Rod	Tige	Stange	Varilla	
	12	8000 70552	1	Albero comando frizione	Shaft	Arbre	Welle	Eje	
	13	8000 70554	1	Molla	Spring	Ressort	Feder	Resorte	
	14	8000 55532	1	Bussola	Bushing	Douille	Buchse	Casquillo	
	15	8A00 31386	1	Dado	Nut	Ecrou	Mutter	Tuerca	
	16	8000 29089	1	Rosetta di sicurezza	Washer	Rondelle	Scheibe	Arandela	
	17	8000 70468	1	Mozzo portadischi	Clutch hub	Moyeu porte disque	Scheibenthalernabe	Porta discos	
	18	8000 46428	2	Rosetta	Washer	Rondelle	Scheibe	Arandela	
	19	8000 A1473	1	Coppia ingranaggi primaria (Z 22/72)	Set of matched primary (Z 22/72)	Engrenages primarie (Z 22/72)	Stirnraderpaar(Z 22/72)	Copla engranaje transmisiòn primaria (Z 22/72)	
	20	8A00 25044	2	Cuscinetto a rullini (ø24xØ28x10 mm)	Needle bearing (ø24xØ28x10 mm)	Roulement à aiguilles (ø24xØ28x10 mm)	Nadelkäfig (ø24xØ28x10 mm)	Cojinete (ø24xØ28x10 mm)	
	21	8A00 36849	1	Distanziale	Spacer	Entretoise	Distanzstück	Separador	
	22	8A00 65845	1	Distanziale	Spacer	Entretoise	Distanzstück	Separador	
	23	8000 66954	1	Contralbero d'equilibrio	Layshhaft	Arbre de bal.	Worgelegewelle	Conta eje	
	24	8000 38707	1	Linguetta	Key	Clavette	Keil	Lengüeta americana	
	25	80A0 47665	1	Dado	Nut	Ecrou	Mutter	Tuerca	
	26	8000 04551	2	Rosetta di rasamento (0,3 mm)	Washer (0,3 mm)	Rondelle (0,3 mm)	Scheibe (0,3 mm)	Arandela (0,3 mm)	
	26	8C00 04551	2	Rosetta di rasamento (0,6 mm)	Washer (0,6 mm)	Rondelle (0,6 mm)	Scheibe (0,6 mm)	Arandela (0,6 mm)	
	26	8E00 04551	2	Rosetta di rasamento (0,8 mm)	Washer (0,8 mm)	Rondelle (0,8 mm)	Scheibe (0,8 mm)	Arandela (0,8 mm)	
	26	8G00 04551	2	Rosetta di rasamento (1,0 mm)	Washer (1,0 mm)	Rondelle (1,0 mm)	Scheibe (1,0 mm)	Arandela (1,0 mm)	
	27	8000 54507	1	Linguetta a disco	Key	Clavette	Keil	Lengüeta americana	

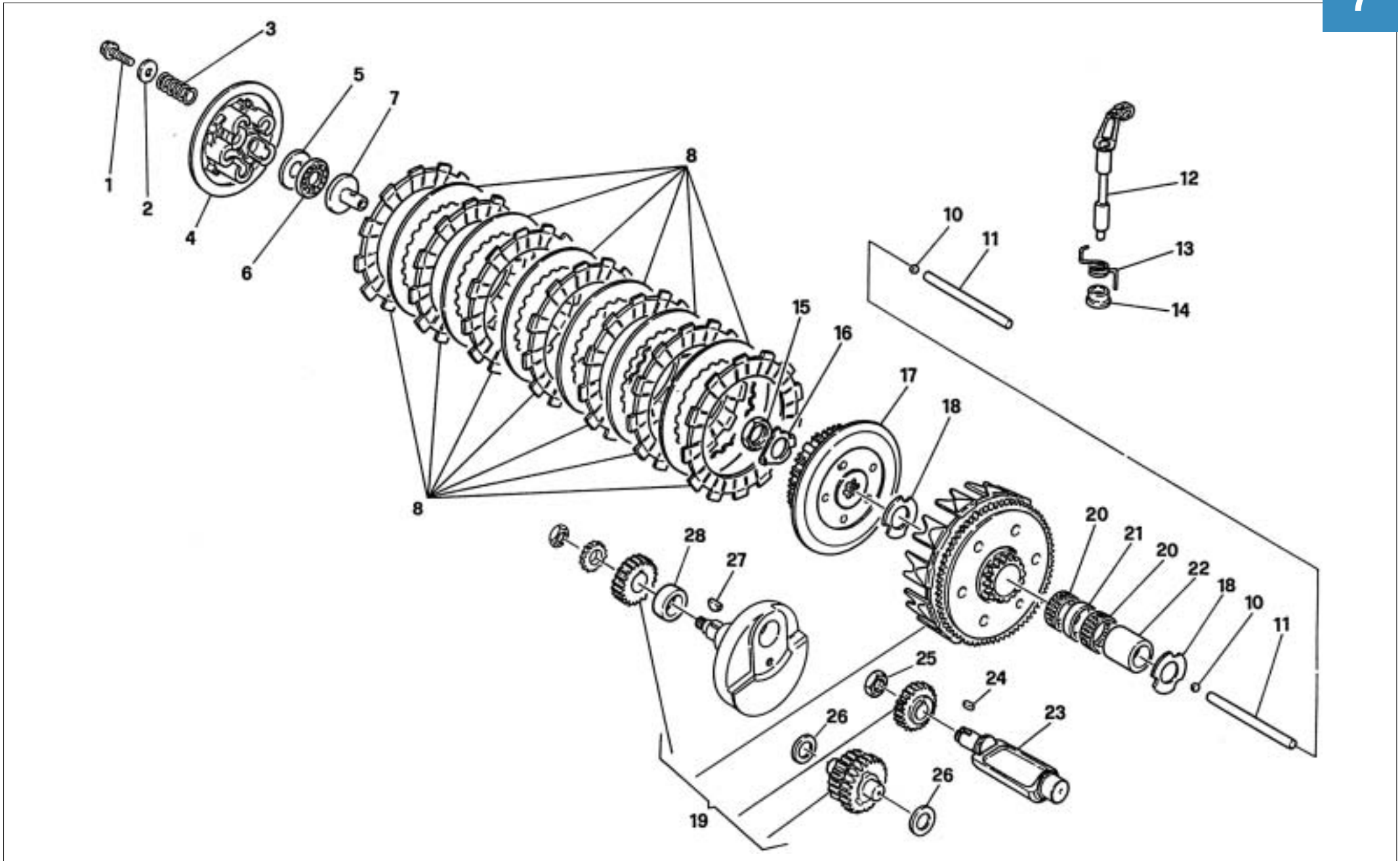

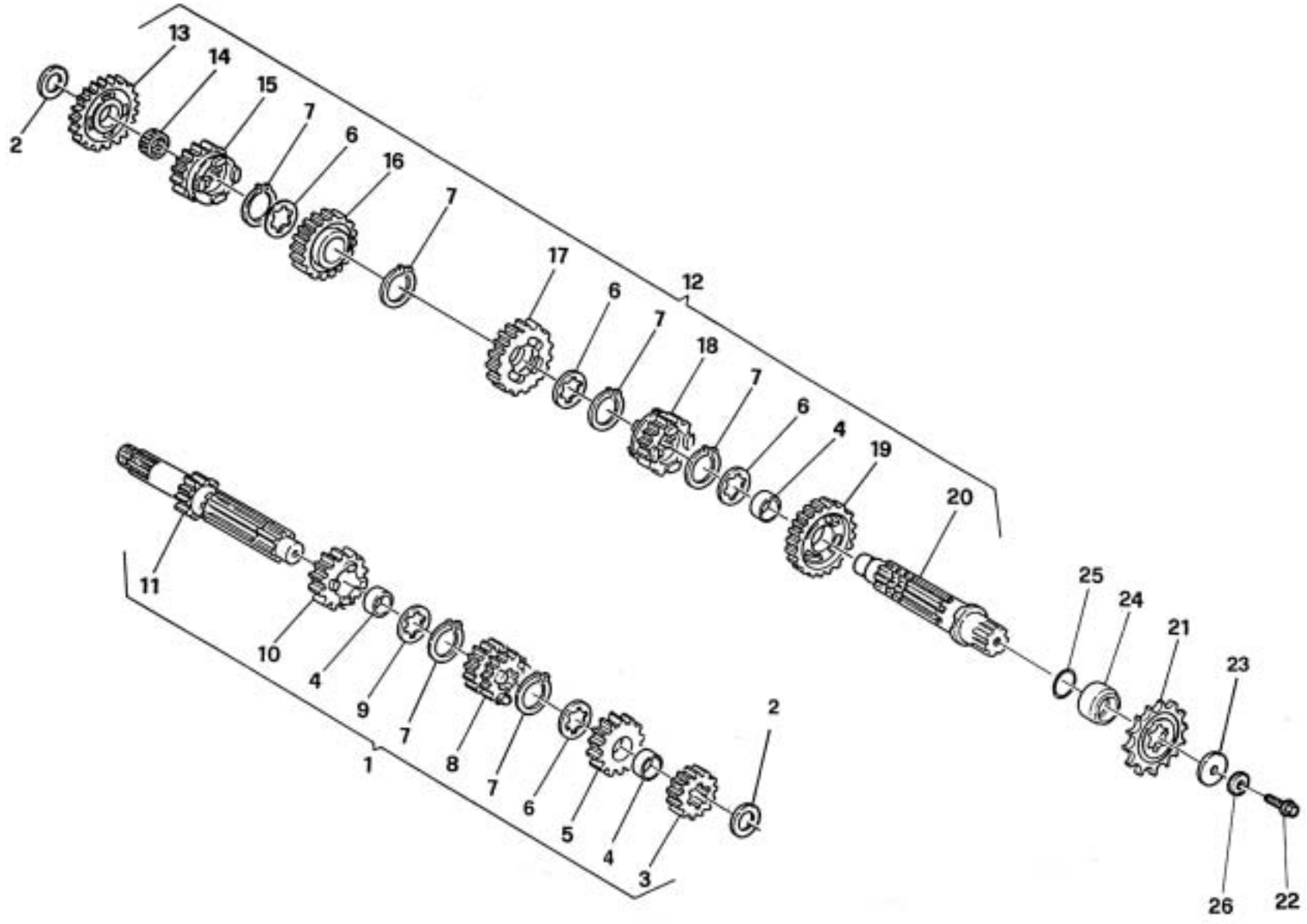

Note Notes Notas	Pos. No. Index Pos.	N. Cod. Code No. Nr. Code Code Nr N. Cod.	Q.tà Q.ty Q.te M.ge C.ad	DENOMINAZIONE	NAME	DESIGNATION	BESHREIBUNG	DENOMINACION	Validità Validité Gültig Validez
	1	8000 75962	1	Assieme albero primario	Main shaft compl.	Arbre primaire compl.	Hauptwelle, Kpl.	Eje primario comp.	
	2	8000 68860	2	Rosetta di rasamento (0,3 mm)	Washer (0,3 mm)	Rondelle (0,3 mm)	Scheibe (0,3 mm)	Arandela (0,3 mm)	
	2	8B00 68860	2	Rosetta di rasamento (0,5 mm)	Washer (0,5 mm)	Rondelle (0,5 mm)	Scheibe (0,5 mm)	Arandela (0,5 mm)	
	2	8C00 68860	2	Rosetta di rasamento (0,6 mm)	Washer (0,6 mm)	Rondelle (0,6 mm)	Scheibe (0,6 mm)	Arandela (0,6 mm)	
	2	8D00 68860	2	Rosetta di rasamento (0,8 mm)	Washer (0,8 mm)	Rondelle (0,8 mm)	Scheibe (0,8 mm)	Arandela (0,8 mm)	
	2	8E00 68860	2	Rosetta di rasamento (1,0 mm)	Washer (1,0 mm)	Rondelle (1,0 mm)	Scheibe (1,0 mm)	Arandela (1,0 mm)	
	2	8F00 68860	2	Rosetta di rasamento (1,2 mm)	Washer (1,2 mm)	Rondelle (1,2 mm)	Scheibe (1,2 mm)	Arandela (1,2 mm)	
	3	8000 75967	1	Ingr. seconda vel. A. P. (Z15)	2nd gear, counter shaft (Z15)	Engrenage 2ème A.P. (Z15)	Zahnrad 2 (Z15)	Engr. 2° velocidad (Z15)	
	4	8A00 61261	3	Bussola	Bush	Douille	Buchse	Casquillo	
	5	8000 75966	1	Ingr. sesta vel A. P. (Z23)	6th gear, main shaft (Z23)	Pignon 6ème A.P. (Z23)	Zahnrad 6 A.W. (Z23)	Engranaje 6° velocidad (Z23)	
	6	8000 72800	3	Rosetta	Washer	Rondelle	Scheibe	Arandela	
	7	8000 31768	6	Anello elastico	Split ring	Anneau ressort	Sprengring	Anillo elástico	
	8	8000 75965	1	Ingr. A.P. 3ª e 4ª (Z18/20)	3rd and 4 th gears, main shaft (Z18/20)	Engrenage 3ème et 4 éme (Z18/20)	Zahnrad A.W. 3 u. 4.Gang (Z18/20)	Engr. 3° y 4° velocidad (Z18/20)	
	9	8000 36023	1	Rosetta	Washer	Rondelle	Scheibe	Arandela	
	10	8000 75964	1	Ingr. quinta vel. A. P. (Z22)	5th gear, main shaft (Z22)	Pignon A.P. 5ème (Z22)	Zahnrad 5 A.W. (Z22)	Engranaje 5° velocidad (Z22)	
	11	8000 75963	1	Albero primario (Z13)	Main shaft (Z13)	Arbre primaire (Z13)	Hauptwelle (Z13)	Eje primario (Z13)	
	12	8000 75968	1	Assieme albero secondario	Layshaft compl.	Arbre secondaire compl.	Vorgelegewelle, Kpl.	Eje secundario comp.	
	13	8000 75975	1	Ingr. prima vel. A. S. (Z35)	1st gear, counter shaft (Z35)	Pignon 1ère A.S. (Z35)	Zahnrad 1 N.W. (Z35)	Engr. 1° velocidad (Z35)	
	14	8000 40449	1	Cuscinetto a rullini (ø16xø20x10 mm)	Needle bearing (ø16xø20x10 mm)	Roulement à aiguilles (ø16xø20x10 mm)	Nadelkäfig (ø16xø20x10 mm)	Cojinete (ø16xø20x10 mm)	
	15	8000 75974	1	Ingr. quinta vel. A. S. (Z21)	5th gear, counter shaft (Z21)	Pignon 5ème A.S. (Z21)	Zahnrad 5 N.W. (Z21)	Engr. 5° velocidad (Z21)	
	16	8000 75973	1	Ingr. quarta vel. A. S. (Z22)	4th gear, counter shaft (Z22)	Engrenage 4ème A.S. (Z22)	Zahnrad 4 N.W. (Z22)	Engr. 4° velocidad (Z22)	
	17	8000 75972	1	Ingran. terza vel. A. S. (Z24)	3rd gear, counter shaft (Z24)	Pignon 3ème A.S. (Z24)	Zahnrad 3 N.W. (Z24)	Engr. 3° velocidad (Z24)	
	18	8000 75971	1	Ingr. sesta vel. A. S. (Z20)	6th gear, counter shaft (Z20)	Pignon 6ème A.S. (Z20)	Zahnrad 6 N.W. (Z20)	Engr. 6° velocidad (Z20)	
	19	8000 75970	1	Ingran. sec. vel. A. S. (Z27)	2nd gear, counter shaft (Z27)	Pignon 2ème A.S. (Z27)	Zahnrad 2 N.W. (Z27)	Engr. 2° velocidad (Z27)	
	20	8000 75969	1	Albero secondario	Layshaft	Arbre secondaire	Vorgelegewelle	Eje secundario	
WR	21	8A00 65955	1	Pignone uscita cambio (Z13)	Pinion (Z13)	Pignon (Z13)	Ritzel (Z13)	Piñón (Z13)	
R	21	8000 65955	1	Pignone uscita cambio (Z12)	Pinion (Z12)	Pignon (Z12)	Ritzel (Z12)	Piñón (Z12)	
SR	21	8B00 65955	1	Pignone uscita cambio (Z14)	Pinion (Z14)	Pignon (Z14)	Ritzel (Z14)	Piñón (Z14)	
	22	60N1 01140	1	Vite	Screw	Vis	Schraube	Tornillo	
	23	8000 73649	1	Rosetta	Washer	Rondelle	Scheibe	Arandela	
	24	8000 31744	1	Distanziale	Spacer	Entretoise	Distanzstück	Separador	

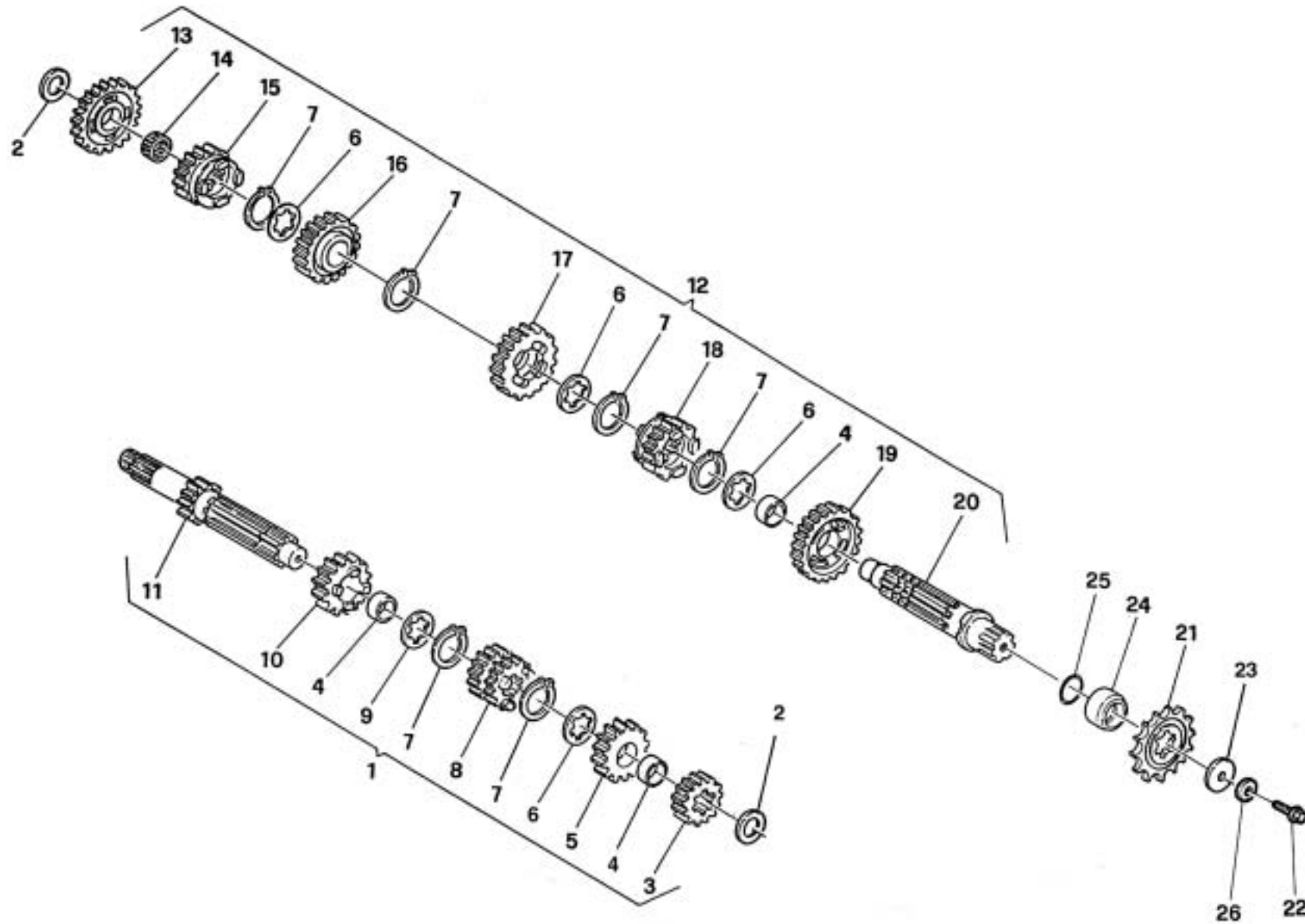

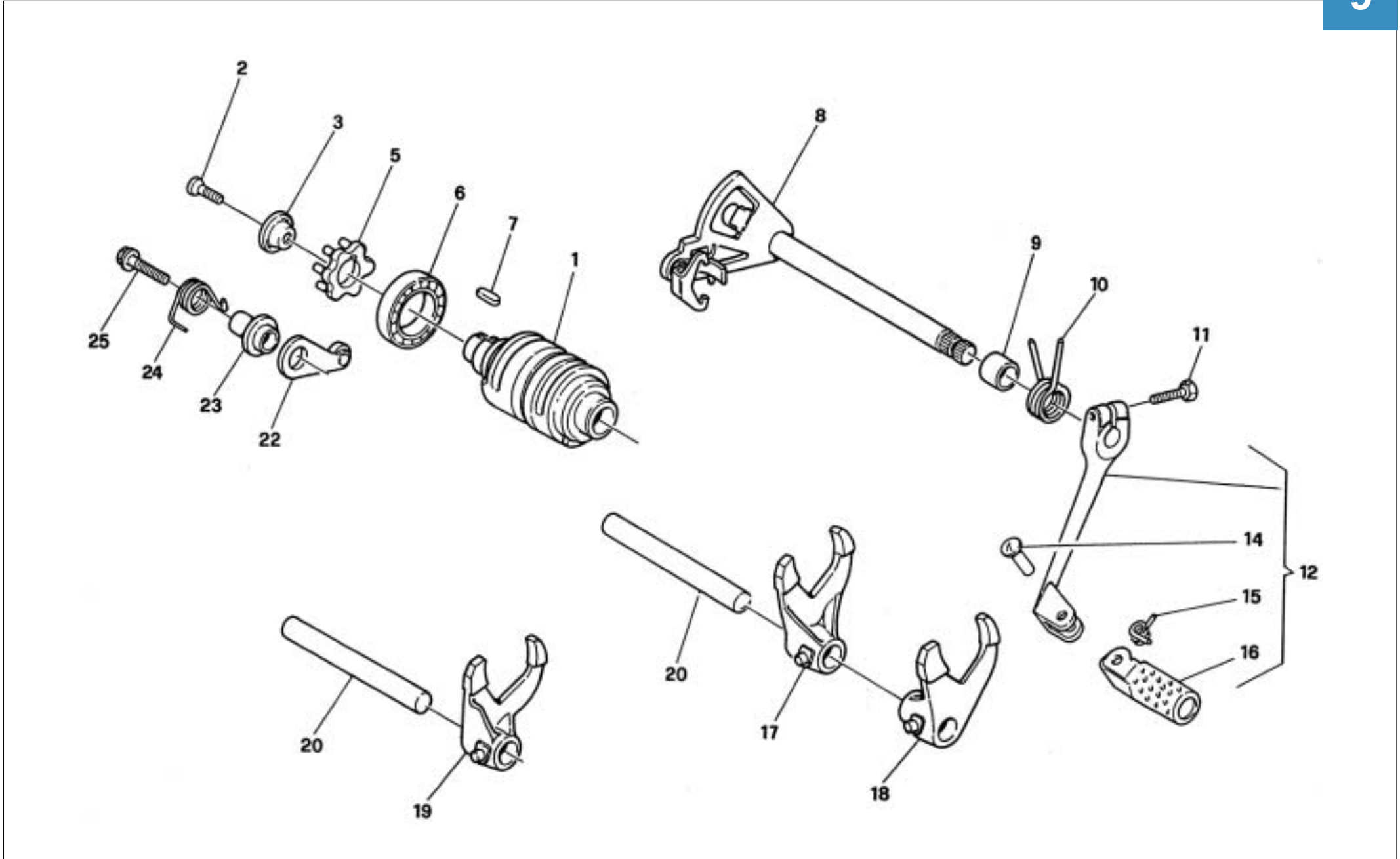

Note Notes Notes Marke Notas	Pos. No. N. Index Pos.	N. Cod. Code No. Nr. Code Code Nr N. Cod.	Q.tà Q.ty Q.te M.ge C.ad	DENOMINAZIONE	NAME	DESIGNATION	BESHREIBUNG	DENOMINACION	Validità Validity Validité Gültig Validez
	1	8000 77347	1	Albero comando forcelle	Fork driving shaft	Arbre de commande fourche	Steuerwelle f. Gabel	Eje mando horquilla	
	2	8000 47496	1	Vite	Screw	Vis	Schraube	Tornillo	
	3	8000 38708	1	Rosetta	Washer	Rondelle	Scheibe	Arandela	
	5	8000 38706	1	Rocchetto	Sprocket	Rochet	Spule	Piñon	
	6	8000 65884	1	Cuscinetto a sfere (ø25xø37x7 mm)	Ball bearing (ø25xø37x7 mm)	Roulement à billes (ø25xø37x7 mm)	Kugellager (ø25xø37x7 mm)	Cojinete de bolas (ø25xø37x7 mm)	
	7	8000 38707	1	Linguetta	Woodruff key	Clé woodruff	Federkeil	Lengüeta	
	8	8000 65975	1	Assieme selettore	Selector assembly	Ensemble sélecteur	Aggregat Wählschalter	Juego selector	
	9	8A00 46226	1	Distanziale	Spacer	Entretoise	Distanzstück	Separador	
	10	8000 46225	1	Molla	Spring	Ressort	Feder	Resorte	
	11	8000 62728	1	Vite	Screw	Vis	Schraube	Tornillo	
E	12	8000 72431	1	Assieme leva comando cambio	Crank lever assy	Levier compl.	Hebel kpl.	Pedal mando cambio compl.	
	12	8000 76605	1	Assieme leva comando cambio	Crank lever assy	Levier compl.	Hebel kpl.	Pedal mando cambio compl.	
	14	8000 70217	1	Rivetto	Rivet	Rivet	Niet	Remarche	
	15	8000 70216	1	Molla	Spring	Ressort	Feder	Resorte	
	16	8000 70215	1	Pedalino	Pedal	Pedale	Pedal	Pedal	
	17	8000 76132	1	Forcella com. ingr. 1ª, 4ª vel.	Fork gear shifter 1st, 4th	Fourche 1ère, 4ème	Schaltgabel 1. 4. Gang	Horquilla compl. engr. 1°, 4°	
	18	8000 67011	1	Forcella ingr 2ª e 3ª veloc.	2nd & 3rd gear control fork	Fourche c.de 2ème & 3ème	Gabel Zahnr. 2. & 3. Geschw.	Horquilla engr. 2° y 3° vel.	
	19	8000 76133	1	Forcella ingr.5ª e 6ª velocità	5th & 6th gear control fork	Fourche c.de 5ème & 6ème	Gabel Zahnr. 5. & 6. Geschw.	Horquilla engr. 5° y 6° vel.	
	20	8000 35876	2	Perno forcella	Pin	Pivot	Stift	Perno	
	22	8A00 65895	1	Saltarello fissa marce	Gear fixing click	Cliquet	Strumhaken	Salt. fijo marchas	
	23	8000 66962	1	Bussola	Bushing	Douille	Buchse	Manguito	
	24	8000 65921	1	Molla	Spring	Ressort	Feder	Resorte	
	25	8000 62730	1	Vite	Screw	Vis	Schraube	Tornillo	

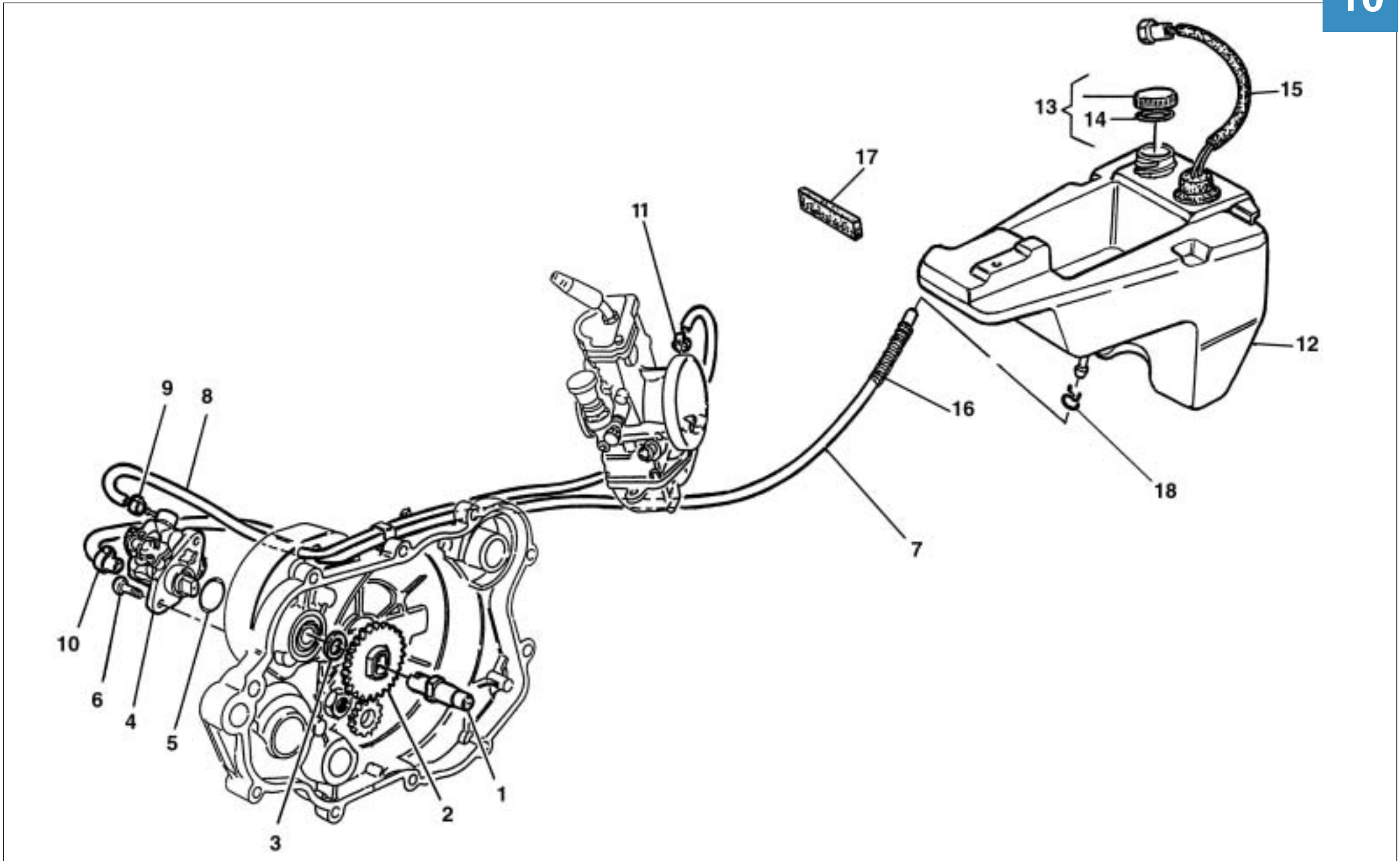

Note Notes Notes Marke Notas	Pos. No. N. Index Pos.	N. Cod. Code No. Nr. Code Code Nr N. Cod.	Q.tà Q.ty Q.te M.ge C.ad	DENOMINAZIONE	NAME	DESIGNATION	BESCHREIBUNG	DENOMINACION	Validità Validity Validité Gültig Validez
	1	8000 67024	1	Albero di rinvio	Lay shaft	Arbre renvoi	Vorgelegewelle	Eje reenvío	
	2	8000 65935	1	Ingran. com. pompa (Z32)	Pump gear (Z32)	Engrenage pompe (Z32)	Zahnrad f. Pumpe (Z32)	Engranaje com. bomba (Z32)	
	3	8F00 28960	1	Rosetta di rasamento	Washer	Rondelle	Scheibe	Arandela	
	4	8000 67025	1	Pompa olio	Oil pump	Pompe à huile	Ölpumpe	Anillo de retención	
	5	8000 17693	1	Anello OR	O Ring	Bague OR	O Ring	Anillo OR	
	6	8000 24962	2	Vite	Screw	Vis	Schraube	Tornillo	
	7	8N00 68873	1	Condotto	Duct	Conduit	Rohr	Conducto	
	8	8A00 33272	1	Condotto	Duct	Conduit	Rohr	Conducto	
	9	8000 49642	1	Fascetta	Clamp	Collier	Schelle	Banda	
	10	8000 56458	1	Fascetta	Clamp	Collier	Schelle	Banda	
	11	8000 33273	2	Fascetta	Clamp	Collier	Schelle	Banda	
	12	8000 94721	1	Serbatoio olio	Oil tank	Reservoir huile	Öltank	Depósito aceite	
	13	8000 53717	1	Tappo	Plug	Bouchon	Verschluss	Tapón	
	14	8000 56722	1	Anello di tenuta	Seal ring	Bague d'étanchéité	Dichtungsring	Anillo de retención	
	15	8A00 81900	1	Interruttore livello olio	Oil level switch	Interrupteur du niveau d'huile	Schalter Oelstand	Interruptor nivel aceite	
	16	80A0 64805	1	Molla sostegno cavi	Spring	Ressort	Feder	Resorte	
	17	8000 96739	1	Spessore elastico	Spacer	Entretoise	Distanzstück	Separador	
	18	8000 18922	1	Anello elastico	Split ring	Anneau ressort	Sprengring	Anillo elástico	

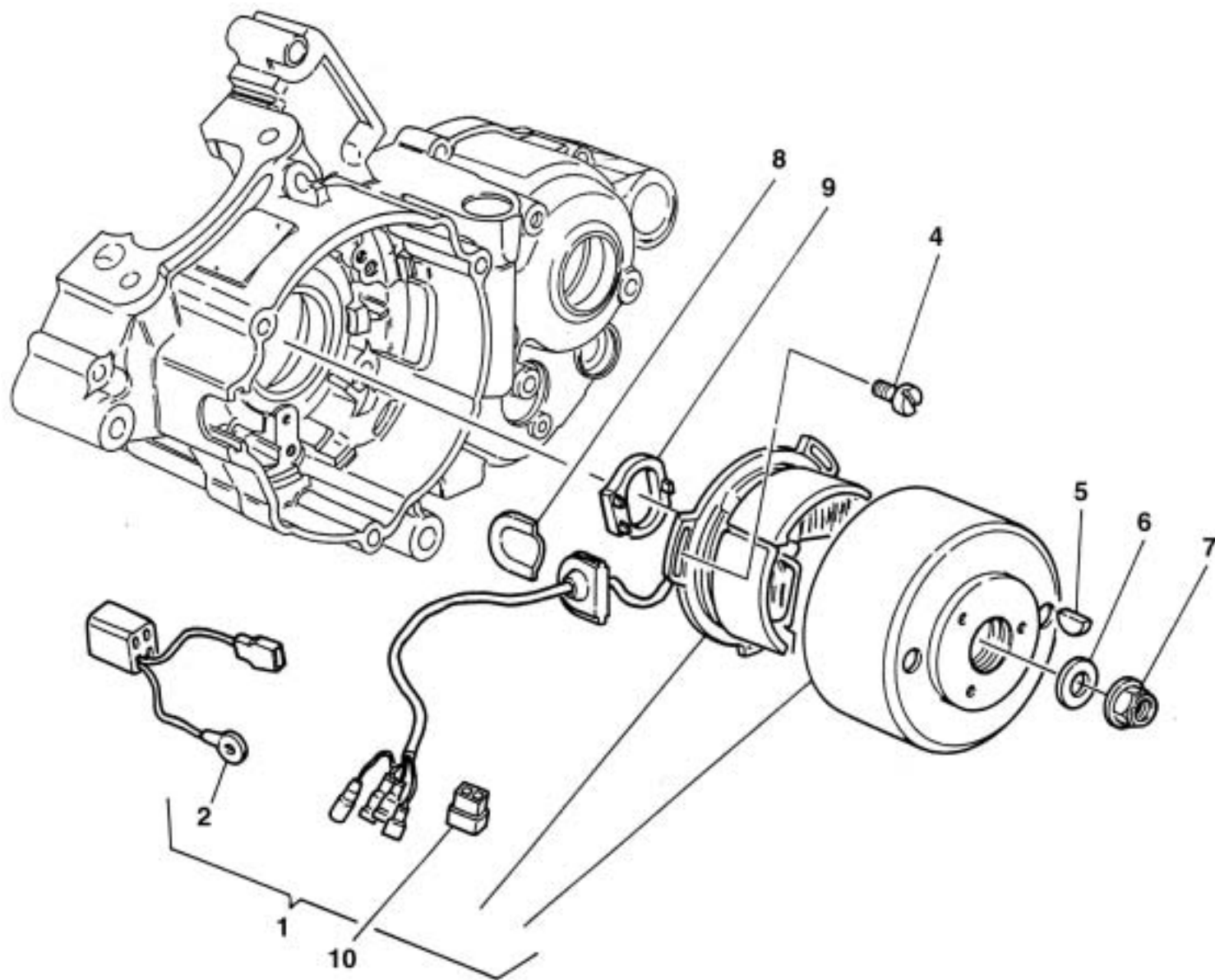

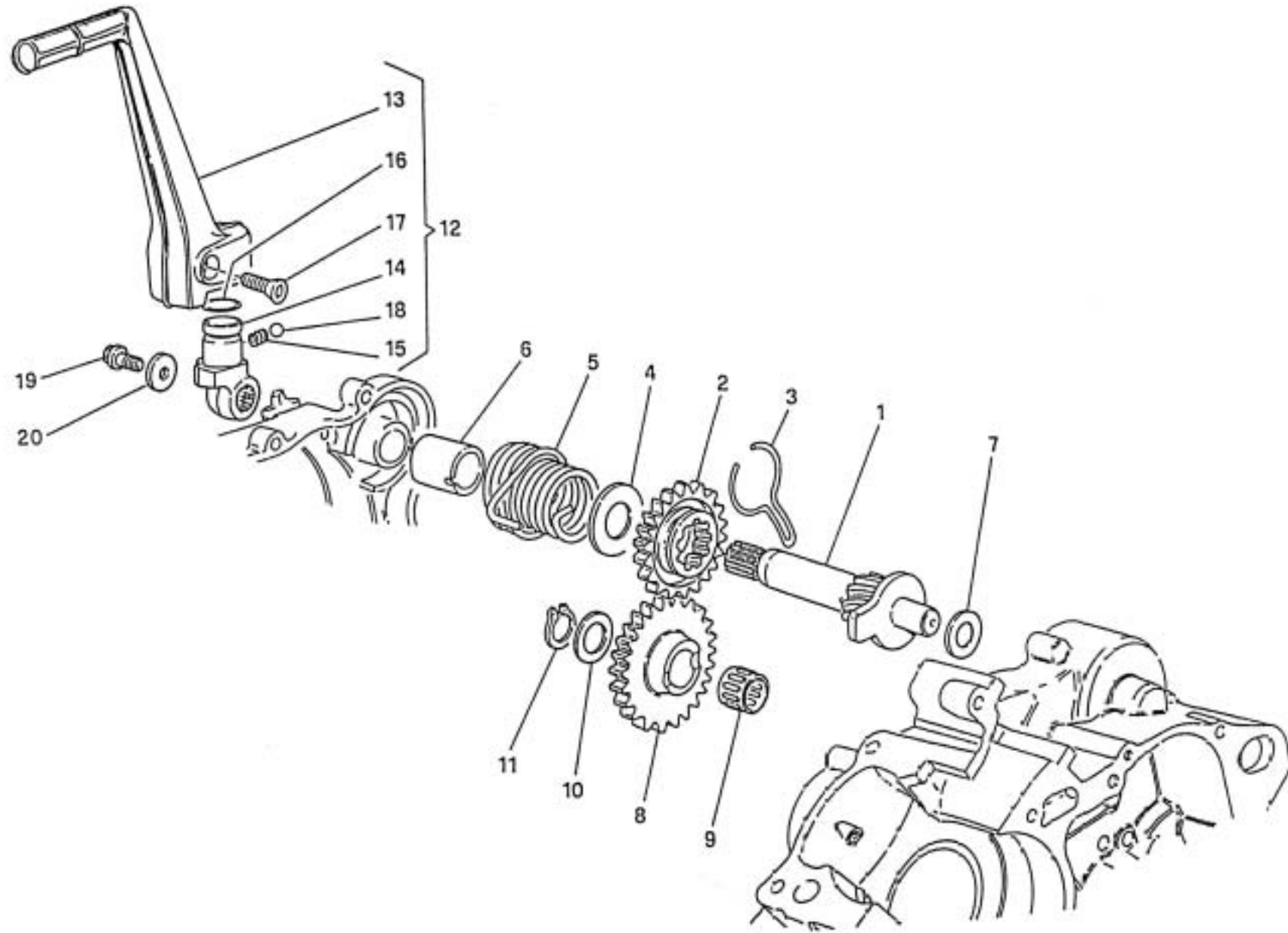



wre 125 dual purpose
sm 125 s / 2004

TAVOLA
DRAWING
TABLE
BILD
TABLA

11A

AVVIAMENTO A PEDALE - KICK STARTER
PEDAL DE MISE EN MARCHE - ANLASSER
PUESTA EN MARCHA A PEDAL

Note Notes Notes Marke Notas	Pos. No. N. Index Pos.	N. Cod. Code No. Nr. Code Code Nr N. Cod.	Q.tà Q.ty Q.te M.ge C.ad	DENOMINAZIONE	NAME	DESIGNATION	BESHREIBUNG	DENOMINACION	Validità Validity Validité Gültig Validez
	1	8000 67017	1	Albero avviamento	Starter crank shaft	Arbre de démarrage	Kickstarterwelle	Eje arranque	
	2	8000 67015	1	Ingranaggio (Z22)	Gear (Z22)	Engrenage (Z22)	Zahnrad (Z22)	Engranaje (Z22)	
	3	8000 67016	1	Molla di frizione	Spring	Resort	Feder	Resorte	
	4	8E00 18282	2	Rosetta	Washer	Rondelle	Scheibe	Arandela	
	5	8000 83095	1	Molla di ritorno leva	Spring	Resort	Feder	Resorte	
	6	8000 67020	1	Distanziale	Spacer	Entretoise	Distanzstück	Separador	
	7	8D00 10789	1	Rosetta	Washer	Rondelle	Scheibe	Arandela	
	8	8000 67013	1	Ingranaggio di rinvio (Z25)	Gear (Z25)	Engrenage (Z25)	Zahnrad (Z25)	Engranaje (Z25)	
	9	8A00 19946	1	Cuscinetto a rulli	Needle bearing	Roulement à l'aguilles	Nadelkafig	Cojinete	
	10	8E00 01049	1	Rosetta	Washer	Rondelle	Scheibe	Arandela	
	11	66N0 21203	1	Anello elastico	Split ring	Anneau ressort	Sprengring	Anillo elástico	
	12	8000 67045	1	Leva avviamento completa	Starter lever assy	Levier démarrage compl.	Hebelanlasser kpl.	Palanca arranque compl.	
	13	8000 74415	1	Leva avviamento	Lever	Levier	Hebelanlasser	Palanca	
	14	8000 67047	1	Mozzetto	Hub	Moyeau	Radnabe	Cubo	
	15	8000 66946	1	Molla	Spring	Ressort	Feder	Resorte	
	16	8000 36380	1	Anello OR	Ring	Anneau OR	RING OR	Anillo OR	
	17	8A00 38287	1	Vite	Screw	Vis	Scchraube	Tornillo	
	18	6BN0 21506	1	Sfera	Ball	Bille	Kugel	Esfera	
	19	8000 62725	1	Vite	Screw	Vis	Scchraube	Tornillo	
	20	8000 79973	1	Rosetta	Washer	Rondelle	Scheibe	Arandela	

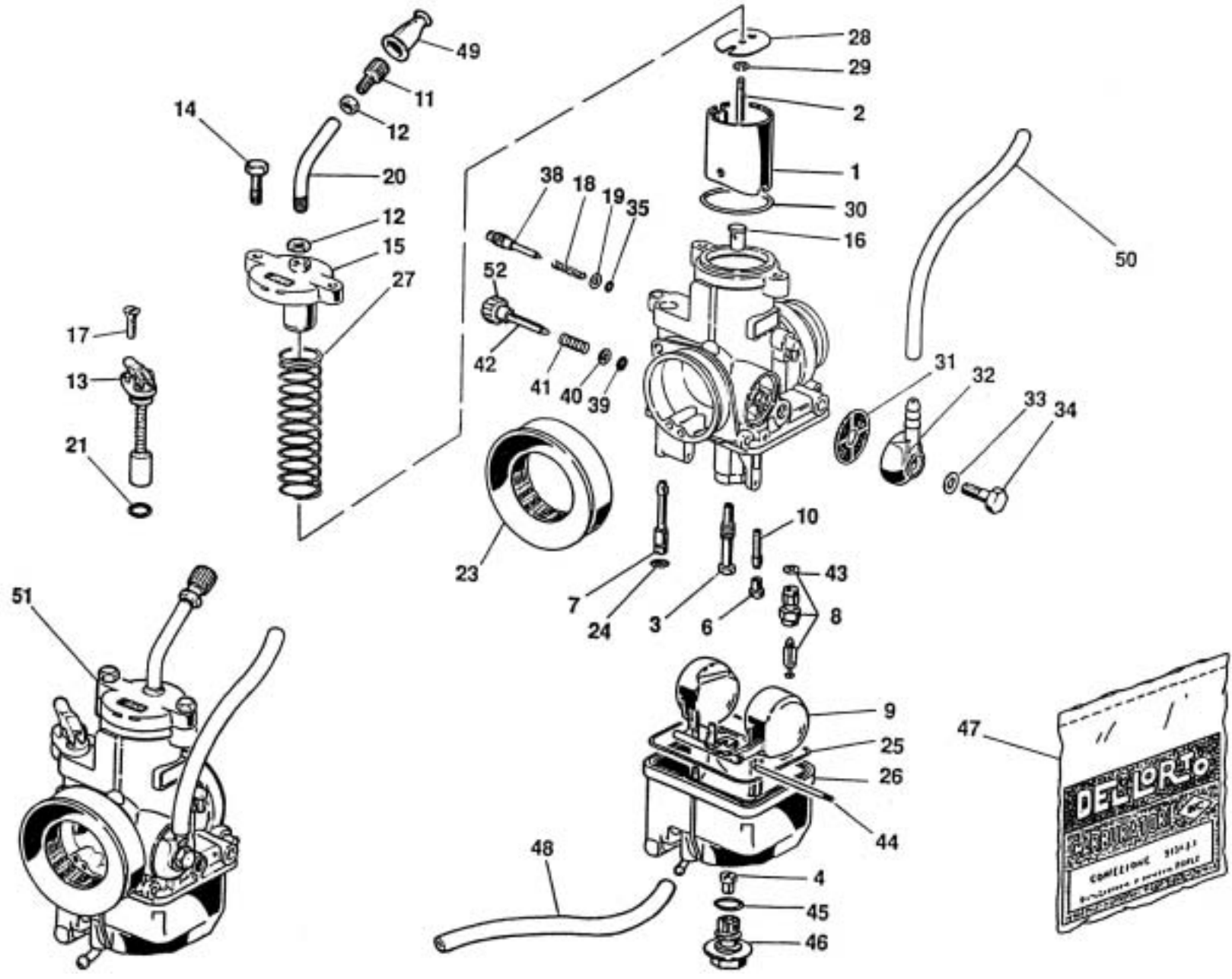



wre 125 dual purpose
sm 125 s / 2004

TAVOLA
DRAWING
TABLE
BILD
TABLA

12

CARBURATORE - CARBURETOR
CARBURATEUR - VERGASER
CARBURADOR

Note Notes Marke Notas	Pos. No. N. Index Pos.	N. Cod. Code No. Nr. Code Code Nr N. Cod.	Q.tà Q.ty Q.te M.ge C.ad	DENOMINAZIONE	NAME	DESIGNATION	BESHREIBUNG	DENOMINACION	Validità Validity Validité Gültig Validez
	1	80C0 36681	1	Valvola gas (50)	Throttle valve (50)	Papillon de gaz (50)	Drosselklappe (50)	Válvula (50)+	
R	1	80D0 36681	1	Valvola gas (45)	Throttle valve (45)	Papillon de gaz (45)	Drosselklappe (45)	Válvula (45)	
	2	80T0 36683	1	Spillo conico (X3)	Needle (X3)	Pointeau conique (X3)	Kon. Nadel (X3)	Pasador cónico (X3)	
	3	8B00 49525	1	Polverizzatore (BN 264)	Fuel nozzle (BN 264)	Pulvérisateur (BN 264)	Einspritzdüse (BN 264)	Pulverizador (BN 264)	
R	3	8G00 49525	1	Polverizzatore (BN 266)	Fuel nozzle (BN 266)	Pulvérisateur (BN 266)	Einspritzdüse (BN 266)	Pulverizador (BN 266)	
	4	80A0 12041	1	Getto massimo (110)	Main jet (110)	Gicleur principal (110)	Hauptdüse (110)	Chiclé máximo (110)	
R	4	80G0 12041	1	Getto massimo (125)	Main jet (125)	Gicleur principal (125)	Hauptdüse (125)	Chiclé máximo (125)	
	6	8B00 87148	1	Getto minimo (60)	Idle jet (60)	Gicleur minimum (60)	Leerlaufdüse (60)	Chiclé mínimo (60)	
	7	80F0 12032	1	Getto avviamento (65)	Starting jet (65)	Gicleur de starter (65)	Starterdüse (65)	Chiclé arranque (65)	
	8	8000 30794	1	Valvola a spillo (300)	Needle valve (300)	Soupape à pointeau (300)	Nadelventi (300)(300)	Válvula de aguja (300)	
	9	80C0 35357	1	Galleggiante (g 9,5)	Float (g 9,5)	Flotteur (g 9,5)	Schwimmer (g 9,5)	Flotador (g 9,5)	
	10	80B0 63846	1	Emulsionatore minimo	Emulsifier	Emulsionneur	Mischer	Emulsionador	
	11	8000 51986	1	Vite	Screw	Vis	Schraube	Tornillo	
	12	8000 51987	2	Dado	Nut	Ecrou	Mutter	Tuerca	
	13	8000 32854	1	Dispositivo avviamento	Starting device	Dispositif de démarrage	Startvorrichtung	Dispositivo puesta en marcha	
	14	8000 23981	2	Vite	Screw	Vis	Schraube	Tornillo	
	15	8000 36685	1	Coperchio valvola gas	Throttle valve cover	Couvercle papillon de gaz	Drosselkappe Deckel	Tapa válvula acelerador	
	16	8000 87150	1	Ugello polverizzatore	Spray nozzle	Buse atomiseur	Einspritzdüse	Injector	
	17	8000 32855	1	Vite	Screw	Vis	Schraube	Tornillo	
	18	8000 50472	1	Molla	Spring	Ressort	Feder	Resorte	
	19	8000 23985	1	Rosetta piana	Washer	Rondelle	Scheibe	Arandela	
	20	8000 57401	1	Tubetto	Pipe	Tuyau	Rohr	Tubo	
	21	H	1	Guarnizione	Gasket	Garniture	Dichtung	Junta	
	23	8000 36687	1	Raccordo	Union	Raccord	Anschluss	Empalme	
	24	H	1	Guarnizione	Gasket	Garniture	Dichtung	Junta	
	25	H	1	Guarnizione	Gasket	Garniture	Dichtung	Junta	
	26	8000 64168	1	Vaschetta	Chamber	Cuvette	Becken	Cubeta	
	27	8000 90682	1	Molla	Spring	Ressort	Feder	Resorte	
	28	8000 36682	1	Piastrina	Plate	Plaquette	Plättchen	Placa	
	29	8000 35353	1	Fermaglio spillo conico	Retainer	Arret	Klammer	Pasador cónico	
	30	H	1	Guarnizione	Gasket	Garniture	Dichtung	Junta	
	31	8000 12045	1	Filtro benzina	Fuel filter	Filtre essence	Benzinfilter	Filtro gasolina	
	32	8000 44059	1	Pipetta	Pipette	Pipette	Pipette	Pipa	

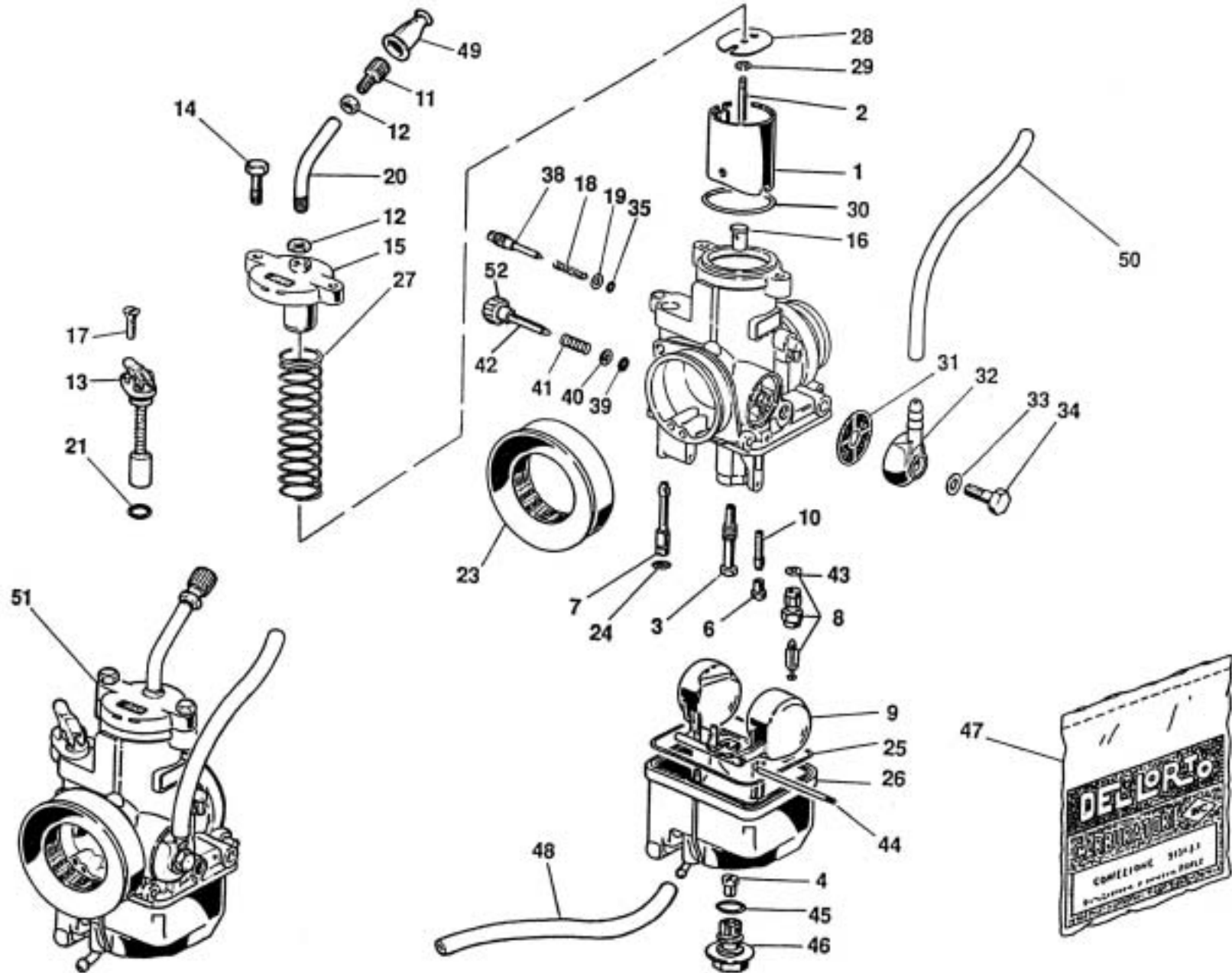



wre 125 dual purpose
sm 125 s / 2004

TAVOLA
DRAWING
TABLE
BILD
TABLA

12

CARBURATORE - CARBURETOR
CARBURATEUR - VERGASER
CARBURADOR

Note Notes Notes Marke Notas	Pos. No. N. Index Pos.	N. Cod. Code No. Nr. Code Code Nr N. Cod.	Q.tà Q.ty Q.te M.ge C.ad	DENOMINAZIONE	NAME	DESIGNATION	BESHREIBUNG	DENOMINACION	Validità Validity Validité Gültig Validez
	33	H	1	Guarnizione	Gasket	Garniture	Dichtung	Junta	
	34	8000 12048	1	Vite	Screw	Vis	Schraube	Tornillo	
	35	H	1	Guarnizione	Gasket	Garniture	Dichtung	Junta	
	38	8000 12033	1	Vite	Screw	Vis	Schraube	Tornillo	
	39	H	1	Guarnizione	Gasket	Garniture	Dichtung	Junta	
	40	8000 23983	1	Rosetta piana	Washer	Rondelle	Scheibe	Arandela	
	41	8000 12030	1	Molla	Spring	Ressort	Feder	Resorte	
	42	8000 12029	1	Vite	Screw	Vis	Schraube	Tornillo	
	43	H	1	Guarnizione	Gasket	Garniture	Dichtung	Junta	
	44	8000 12037	1	Perno galleggiante	Pin	Pivot	Bolzen	Perno	
	45	H	1	Guarnizione	Gasket	Garniture	Dichtung	Junta	
	46	8000 49531	1	Tappo	Plug	Bouchon	Verschluss	Tapón	
	47	8000 64170	1	Gruppo guarnizioni	Gasket set	Groupe garnitures	Dichtungssatz	Grupo juntas	
	48	8B00 55507	1	Tubetto (L=280 mm)	Pipe	Tuyau	Rohr	Tubo	
	48	8D00 55507	1	Tubetto (L=405 mm)	Pipe	Tuyau	Rohr	Tubo	
	49	8000 58660	1	Cappuccio	Cap	Capuchon	Kappe	Capuchòn	
	50	8000 52078	1	Tubetto	Pipe	Tuyau	Rohr	Tubo	
	51	8000 94657	1	Ass. carburatore	Carburetor assy	Carburateur complet	Vegaser, kpl.	Carburador compl.	
	52	8000 57413	1	Pomello	Knob	Poignée	Knopf	Pomo	

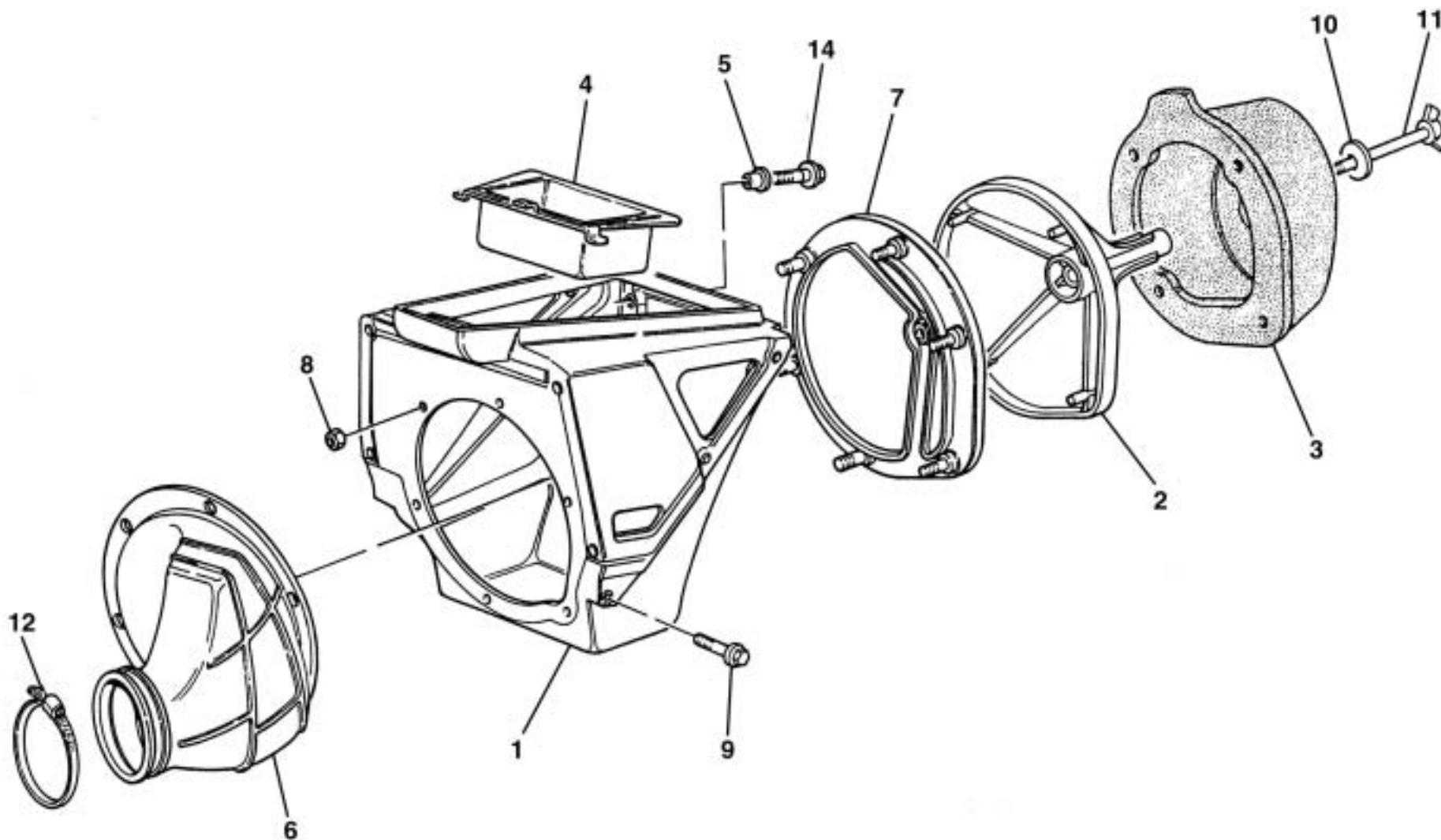



wre 125 dual purpose
sm 125 s / 2004

TAVOLA
DRAWING
TABLE
BILD
TABLA

13

FILTRO ARIA - AIR FILTER
FILTRE AIRE - AIRFILTER
FILTRO DE AIRE

Note Notes Notes Marke Notas	Pos. No. N. Index Pos.	N. Cod. Code No. Nr. Code Code Nr N. Cod.	Q.tà Q.ty Q.te M.ge C.ad	DENOMINAZIONE	NAME	DESIGNATION	BESCHREIBUNG	DENOMINACION	Validità Validity Validité Gültig Validez
	1	8A00 73622	1	Scatola filtro	Air filter box	Boitre filtre	Filterkasten	Caja filtro aire	
	2	8000 69549	1	Gabbia filtro	Cleaner cage	Cage pour filtre	Filterkafig	Caja filro	
	3	8000 72641	1	Filtro aria	Air filter	Filtre à air	Luftfilter	Filtro aire	
	4	8000 75479	1	Coperchio	Cover	Couvercle	Deckel	Tapa	
	5	8000 69429	2	Bussola	Bushing	Duille	Buchse	Manguito	
	6	8D00 73623	1	Raccordo	Union	Raccord	Anschluss	Empalme	
	7	8000 70024	1	Flangia	Flange	Bride	Flansch	Brida	
	8	8000 40718	6	Dado	Nut	Ecrou	Mutter	Tuerca	
	9	8000 62725	2	Vite	Screw	Vis	Schraube	Tornillo	
	10	62N1 15549	1	Rosetta piana	Washer	Rondelle	Scheibe	Arandela	
	11	8A00 37947	1	Vite	Screw	Vis	Schraube	Tornillo	
	12	8E00 99475	1	Fascetta	Clamp	Collier	Schelle	Banda	
	14	8000 62728	2	Vite	Screw	Vis	Schraube	Tornillo	

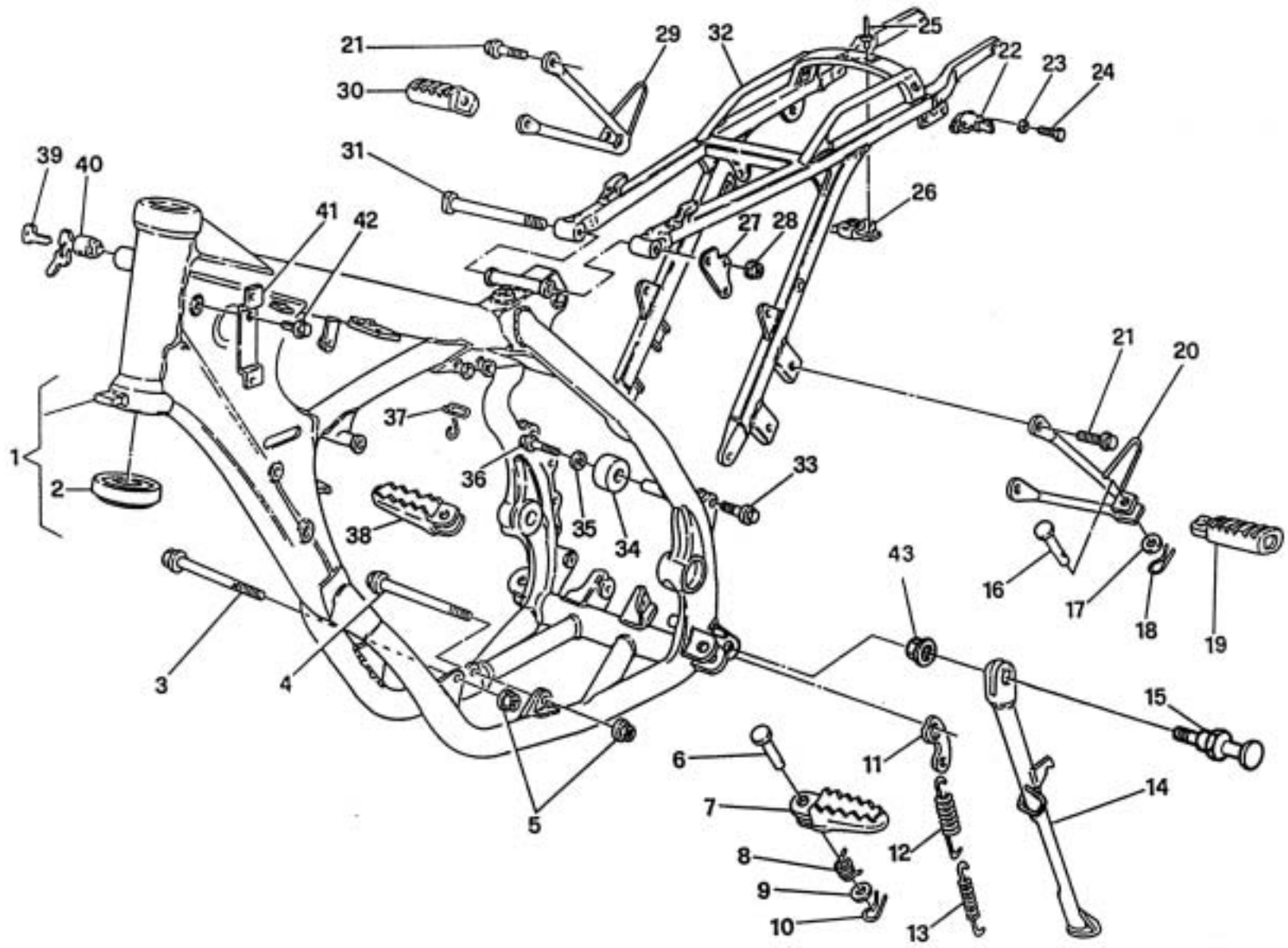

Note Notes Marke Notas	Pos. No. N. Index Pos.	N. Cod. Code No. Nr. Code Code Nr N. Cod.	Q.tà Q.ty Q.te M.ge C.ad	DENOMINAZIONE	NAME	DESIGNATION	BESHREIBUNG	DENOMINACION	Validità Validity Validité Gültig Validez
	1	8A00 98229	1	Parte anteriore compl.	Frame front side assy	Chassis av. compl.	Rahmen kpl.	Cuadro anterior compl.	
	2	1513 07001	2	Cuscinetto a rulli conici (ø25xø50x17,5 mm)	Bearing (ø25xø50x17,5 mm)	Roulement à rouleaux coniques (ø25xø50x17,5 mm)	Lager (ø25xø50x17,5 mm)	Cojinete de rodillos cónicos (ø25xø50x17,5 mm)	
E	3	8A00 73458	1	Perno ant. fiss. motore (M8x115 mm)	Pin (M8x115 mm)	Pivot (M8x115 mm)	Bolzen (M8x115 mm)	Perno (M8x115 mm)	
	3	8N00 73458	1	Perno ant. fiss. motore (M8x120 mm)	Pin (M8x120 mm)	Pivot (M8x120 mm)	Bolzen (M8x120 mm)	Perno (M8x120 mm)	
E	4	8B00 73458	1	Perno inf. fiss. motore (M8x130 mm)	Pin (M8x130 mm)	Pivot (M8x130 mm)	Bolzen (M8x130 mm)	Perno (M8x130 mm)	
	4	8P00 73458	1	Perno inf. fiss. motore (M8x135 mm)	Pin (M8x135 mm)	Pivot (M8x135 mm)	Bolzen (M8x135 mm)	Perno (M8x135 mm)	
	5	8000 45498	2	Dado	Nut	Ecrou	Mutter	Tuerca	
	6	8000 73140	2	Perno	Pin	Pivot	Bolzen	Perno	
	7	80A0 89962	1	Pedana sinistra	L.H. foot-rest	Repose-pieds	L. Fussraste	Pedal del. i.comp.	
	8	8000 89882	1	Molla Dx	R.H. spring	Ressort D.	Feder Rechte	Resorte der.	
	8	8A00 89882	1	Molla Sx	L.H. spring	Ressort G.	Feder Linke	Resorte iz.	
	9	8A00 01815	2	Rosetta	Washer	Rondelle	Scheibe	Arandela	
	10	64N1 20068	2	Copiglia	Split pin	Goupille	Splint	Clavija	
	11	8000 84176	1	Piastrina	Plate	Plaque	Platte	Plaque	
	12	8000 62675	1	Molla esterna	Spring	Ressort	Feder	Resorte	
	13	8000 62676	1	Molla interna	Spring	Ressort	Feder	Resorte	
W	14	8C00 95638	1	Gamba laterale	Side stand	Bequille lat.	Seitenständer	Horquilla lateral	
S	14	8B00 95638	1	Gamba laterale	Side stand	Bequille lat.	Seitenständer	Horquilla lateral	
	15	8A00 97976	1	Vite	Screw	Vis	Schraube	Tornillo	
	16	8000 41459	2	Perno	Pin	Pivot	Bolzen	Perno	
	17	62N1 15504	2	Rosetta	Washer	Rondelle	Scheibe	Arandela	
	18	64N1 20048	2	Copiglia	Split pin	Goupille	Splint	Clavija	
	19	8000 66651	1	Poggiapiedi passeggero Sx.	L.H. foot rest support	Support repose pied G.	L. Fussraster	Posapie izq.	
	20	8A00 75432	1	Supporto Sx.	L.H. support	Support G.	Halterung L.	Soporte izq.	
	21	8B00 69056	4	Vite	Screw	Vis	Schraube	Tornillo	
	22	8000 38211	1	Serratura antifurto casco	Lock assy	Serrure compl.	Schloss kpl.	Cerradura compl.	
	23	62N1 15536	2	Rosetta	Washer	Rondelle	Scheibe	Arandela	
	24	8000 62725	2	Vite	Screw	Vis	Schraube	Tornillo	

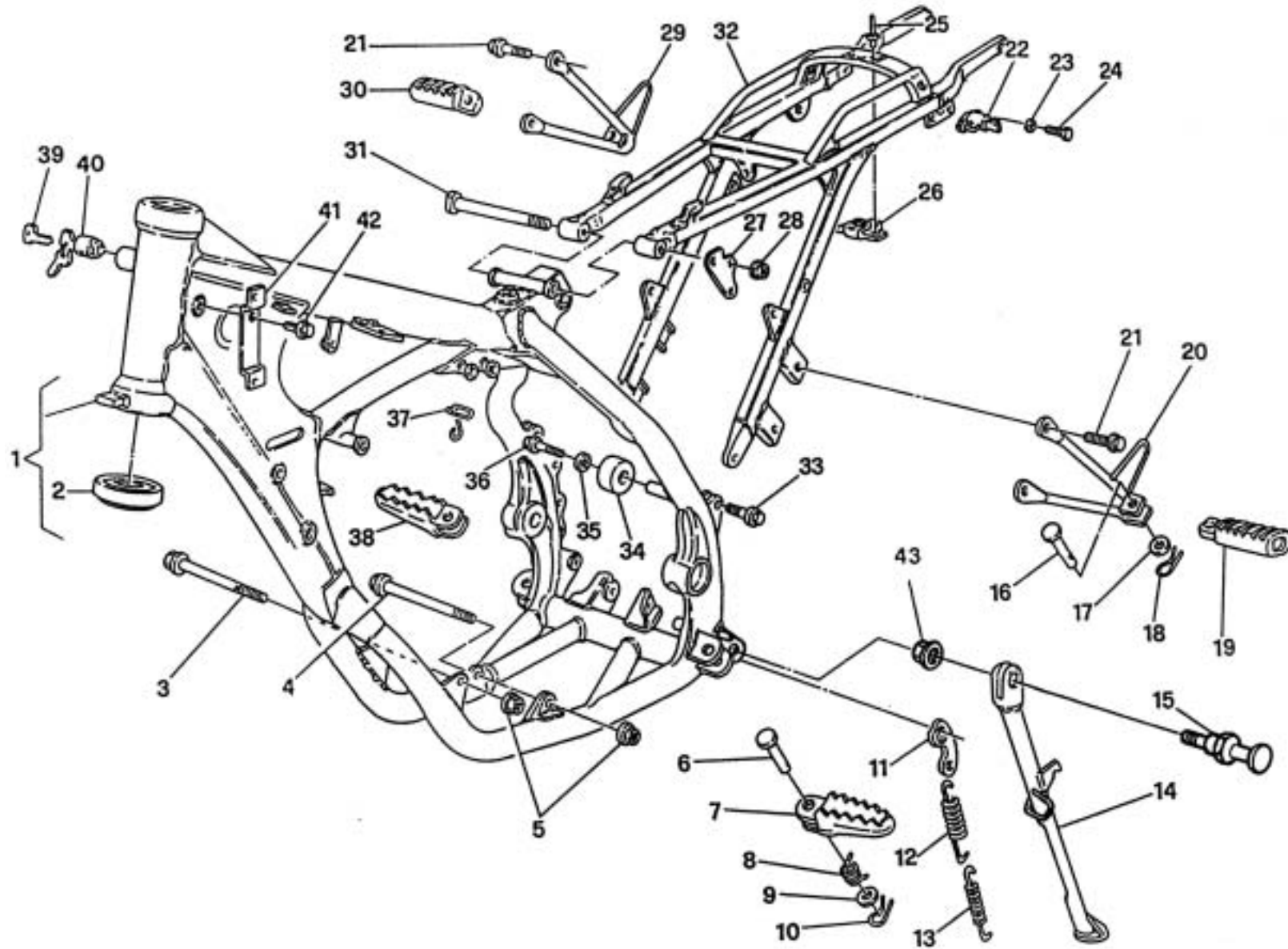



wre 125 dual purpose
sm 125 s / 2004

TAVOLA
DRAWING
TABLE
BILD
TABLA

14

TELAIO, PEDANE - FRAME, FOOT RESTS
CADRE, REPOSE PIEDS - RAHMEN, FUSSBRETT
BASTIDOR, REPOSAPIES

Note Notes Marke Notas	Pos. No. N. Index Pos.	N. Cod. Code No. Nr. Code Code Nr N. Cod.	Q.tà Q.ty Q.te M.ge C.ad	DENOMINAZIONE	NAME	DESIGNATION	BESCHREIBUNG	DENOMINACION	Validità Validity Validité Gültig Validez
	25	8000 33373	2	Rivetto	Rivet	Rivet	Niet	Remache	
	26	8000 69150	1	Piastrina	Plate	Plaquette	Plättchen	Placa	
	27	8000 77385	1	Piastrina	Plate	Plaquette	Plättchen	Placa	
	28	8000 40720	1	Dado autobloccante	Nut	Ecrou	Mutter	Tuerca	
	29	8000 77052	1	Supporto Dx	R.H. support	Support D.	Halterung R.	Soporte der.	
	30	8000 66652	1	Poggiapiedi passeggero Dx.	R.H. foot rest support	Support repose pied D.	R. Fussraster	Posapie der.	
	31	8000 61357	1	Vite	Screw	Vis	Schraube	Tornillo	
	32	8000 94662	1	Parte posteriore telaio	Rear frame side	Chassis arrière	Sattelbrücke	Cuadro posterior	
	33	8000 69056	2	Vite	Screw	Vis	Schraube	Tornillo	
	34	8000 56800	2	Rullo catena	Roller	Aiguille	Rolle	Rodillo	
	35	8000 30319	2	Rosetta	Washer	Rondelle	Scheibe	Arandela	
	36	8000 62725	2	Vite	Screw	Vis	Schraube	Tornillo	
	37	8000 78031	1	Passatubo	Fairlead	Passe cable	Kabelführung	Prensa cable	
	38	80A0 89953	1	Pedana destra	R.H. foot-rest	Repose-pieds D.	R. Fussraste	Pedal del.d.com.	
	39	8000 35531	1	Chiave grezza	Raw key	Clef primitive	Schlüssel	Llave	
	40	8000 43391	1	Serratura antifurto completa	Anti-left lock assy	Serrure anti-vol compl.	Sicherheitsschloss kpl.	Cerradura compl.	
	41	8000 75354	1	Piastrina	Plate	Plaquette	Plättchen	Placa	
	42	8000 62725	1	Vite	Screw	Vis	Schraube	Tornillo	
	43	8000 41513	1	Dado	Nut	Ecrou	Mutter	Tuerca	

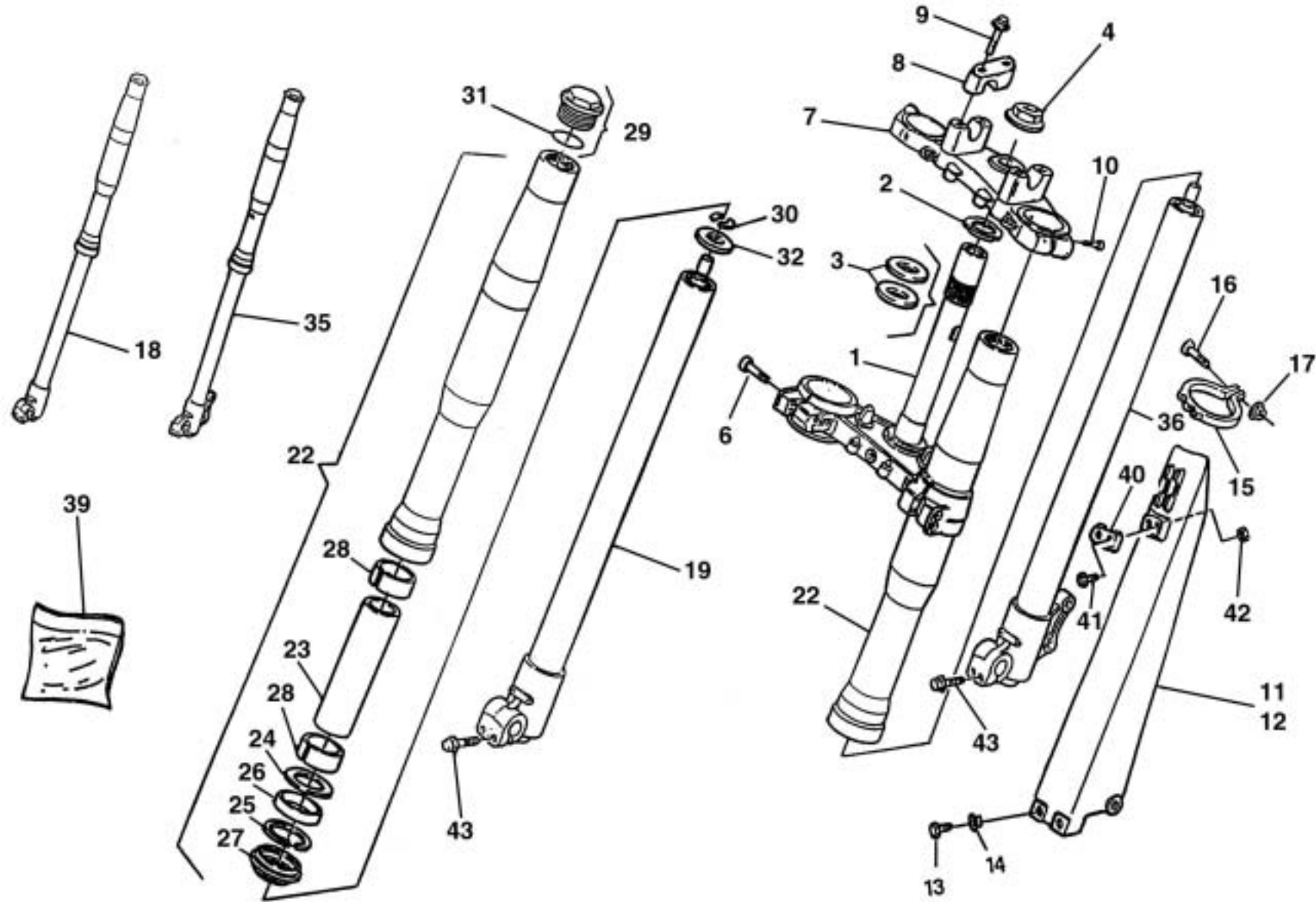

Note Notes Notas	Pos. No. Index Pos.	N. Cod. Code No. Nr. Code Code Nr N. Cod.	Q.tà Q.ty Q.te M.ge C.ad	DENOMINAZIONE	NAME	DESIGNATION	BESHREIBUNG	DENOMINACION	Validità Validity Validité Gültig Validez
	1	8A00 90334	1	Base di sterzo con perno	Steering crown with pin	Socle de direction avec pivot	Gabelbrücke mit Bolzen	Base de dirección con perno	
	2	8000 83395	1	Ghiera registro cuscinetti	Ring nut	Embout	Nutmutter	Virola	
	3	8A00 65503	2	Rosetta piana	Washer	Rondelle	Scheibe	Arandela	
	4	8000 69315	1	Dado	Nut	Ecrou	Mutter	Tuerca	
	6	8000 62796	4	Vite (M8x40 mm)	Screw (M8x40 mm)	Vis (M8x40 mm)	Schraube (M8x40 mm)	Tornillo (M8x40 mm)	
	7	8A00 72387	1	Testa di sterzo	Steering head	Tête direction	Lenkkopf	Cabezal de dirección	
	8	8000 68516	2	Mozzetto superiore	Hub	Moyeau	Radnabe	Cubo	
	9	8000 62733	4	Vite (M8x35 mm)	Screw (M8x35 mm)	Vis (M8x35 mm)	Schraube (M8x35 mm)	Tornillo (M8x35 mm)	
	10	60N1 02557	4	Vite (M8x30 mm)	Screw (M8x30 mm)	Vis (M8x30 mm)	Schraube (M8x30 mm)	Tornillo (M8x30 mm)	
W	11	80G0 69337	1	Protezione Sx	Guard L.H.	Protection D.	Schutz L.	Protección iz.	
S	11	80G0 69337	1	Protezione Sx (cod. col. E)	Guard L.H. (col.code E)	Protection D. (code col. E)	Schutz L. (Code Farbe E)	Protección iz. (cod. col. E)	
S	11	80C0 69337	1	Protezione Sx (cod. col. G)	Guard L.H. (col.code G)	Protection D. (code col. G)	Schutz L. (Code Farbe G)	Protección iz. (cod. col. G)	
W	12	80G0 69338	1	Protezione Dx	Guard R.H.	Protection G.	Schutz R.	Protección der.	
S	12	80G0 69338	1	Protezione Dx (cod. col. E)	Guard R.H. (col.code E)	Protection G. (code col. E)	Schutz R. (Code Farbe E)	Protección der. (cod. col. E)	
S	12	80C0 69338	1	Protezione Dx (cod. col. G)	Guard R.H. (col.code G)	Protection G. (code col. G)	Schutz R. (Code Farbe G)	Protección der. (cod. col. G)	
	13	8000 67997	6	Vite	Screw	Vis	Schraube	Tornillo	
	14	8000 69282	6	Bussola	Bushing	Douille	Buchse	Manguito	
	15	8BA0 70558	2	Anello	Ring	Bague	Ring	Anillo	
	16	8B00 66525	2	Vite	Screw	Vis	Schraube	Tornillo	
	17	8000 40718	2	Dado	Nut	Ecrou	Mutter	Tuerca	
	18	8A00 78996	1	Gamba Dx. compl.	R.H. fork leg assy	Fourche complete D.	Telegabel Kpl. R.	Horquilla D compl.	
	19	8000 97727	1	Gruppo pompante DX	Pumping element R	Element de pompage D	Pumpenelement R	Bombardadora compl. D	
	22	8000 79004	2	Portastelo compl.	Comp. stem holder	Porte-tige compl.	Kpl. Schafthalter	Portavastago	
	23	8000 79005	2	Tubetto	Pipe	Tuyau	Rohr	Tubo	
	24	8000 77378	2	Scodellino	Cup	Cuvette	Teller	Cubeta	
	25	8000 55520	2	Anello elastico	Seal ring	Bague d'étanchéité	Dichtungsring	Anillo elástico	
*	26	8000 37977	2	Anello di tenuta	Seal ring	Bague d'étanchéité	Dichtungsring	Anillo de retención	
*	27	8000 87038	2	Raschiapolvere	Dust scraper	Racloir poudre	Pulverabschaber	Rascador de polvo	
	28	8000 70966	4	Boccola	Bush	Douille	Buchse	Casquillo	
	29	8000 77362	2	Tappo	Plug	Bouchon	Verschluss	Tapòn	
	30	8000 79007	4	Semirondella	Split washer	Demi-rondelle	Halbscheibe	Semiarandela	
*	31	8000 77360	2	Anello OR	O-Ring	Bague OR	O-Ring	Anillo OR	
	32	8000 79006	2	Anello	Ring	Bague	Ring	Anillo	

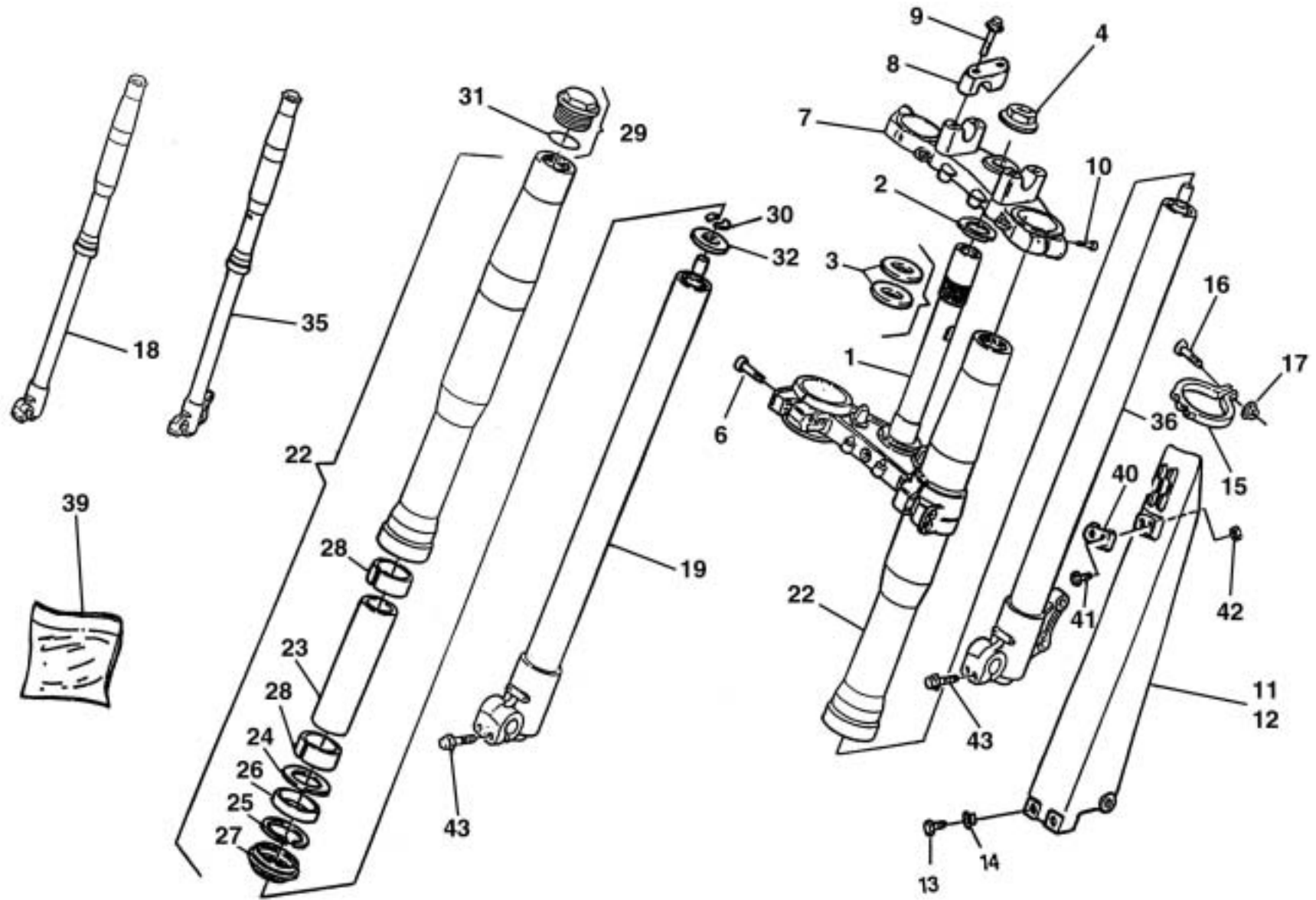

Note Notes Marke Notas	Pos. No. N. Index Pos.	N. Cod. Code No. Nr. Code Code Nr N. Cod.	Q.tà Q.ty Q.te M.ge C.ad	DENOMINAZIONE	NAME	DESIGNATION	BESHREIBUNG	DENOMINACION	Validità Validity Validité Gültig Validez
	35	8B00 78997	1	Gamba Sx. com.	Compl. L.H. leg	Jambe G. compl.	Kpl. L. Bein	Pata izq. compl.	
	36	8000 97726	1	Gruppo pompante SX	L pumping element	Element de pompage G	Pumpenelement L	Bombedora compl. I	
	39	8000 79008	1	Gruppo guarnizioni	Gasket set	Grupe garniture	Dichtungssatz	Grupo juntas	
WS	40	8000 A0633	1	Piastrina Sx (cod. col. E)	Plate (col.code E)	Plaque (code col. E)	Platte (Code Farbe E)	Placa (cod. col. E)	
S	40	80A0 A0633	1	Piastrina Sx (cod. col. G)	Plate (col.code G)	Plaque (code col. G)	Platte (Code Farbe G)	Placa (cod. col. G)	
	41	8A00 67997	2	Vite	Screw	Vis	Schraube	Tornillo	
	42	8000 61355	2	Dado	Nut	Ecrou	Mutter	Tuerca	
	43	80A075097	4	Vite (M6x25 mm)	Screw (M6x25 mm)	Vis (M6x25 mm)	Schraube (M6x25 mm)	Tornillo (M6x25 mm)	
*				I ricambi sono forniti in gruppo pos. 39.	Gasket are supplied in bag ref. N° 39.	Pieces de rechange son fournies en unités pos. 39.	Die Dichtungen sind im Umschlag Bez. Nr 39.	Partes de recambio es provisto en grupo pos. 39.	

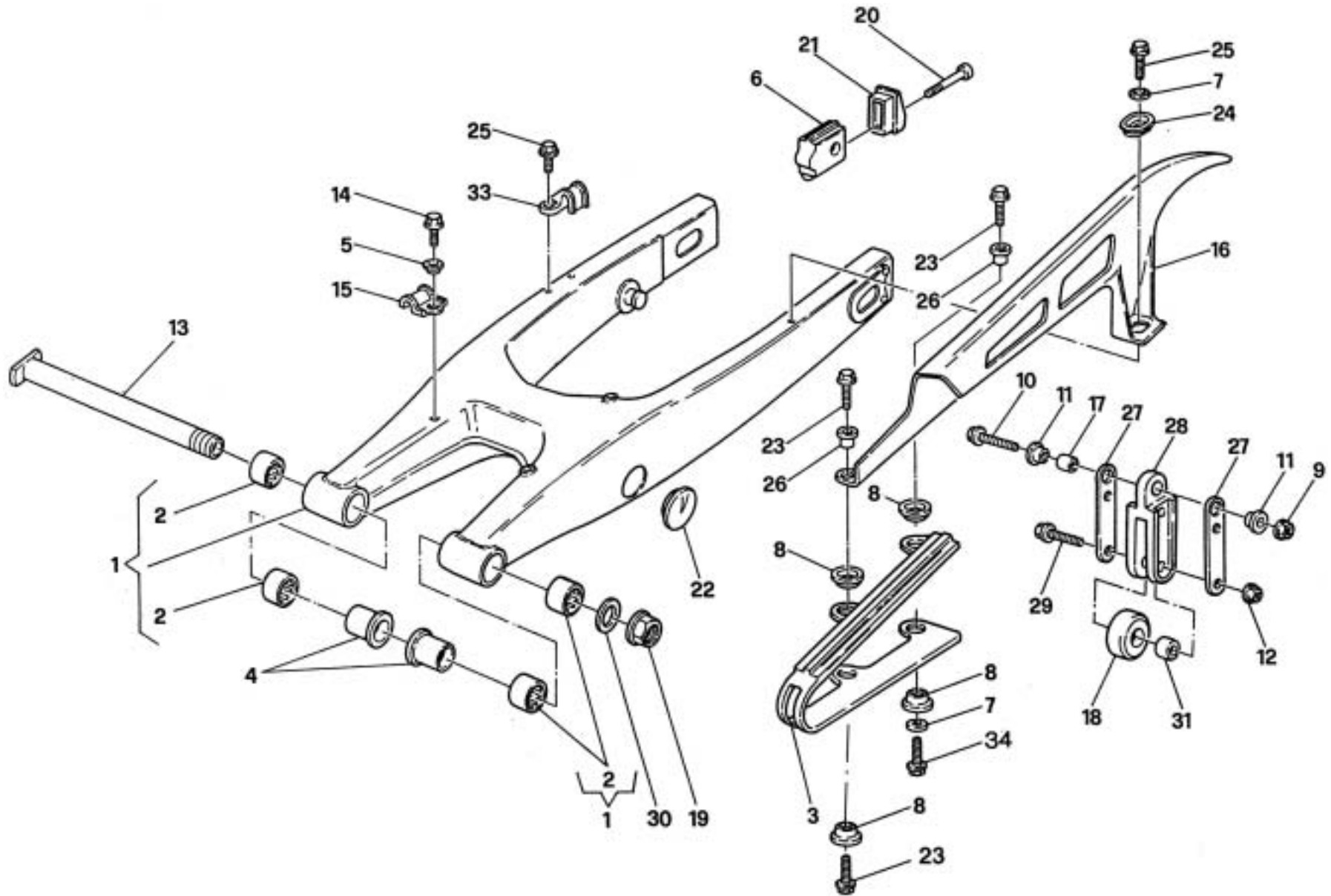

Note Notes Notas	Pos. No. N. Index Pos.	N. Cod. Code No. Nr. Code Code Nr N. Cod.	Q.tà Q.ty Q.te M.ge C.ad	DENOMINAZIONE	NAME	DESIGNATION	BESHREIBUNG	DENOMINACION	Validità Validity Validité Gültig Validez
	1	8A00 74794	1	Forcellone completo	Compl. fork	Fourche complete	Gabel, Kpl.	Horquilla compl.	
	2	8000 76283	4	Gabbia a rullini (ø22xø28x18 mm)	Needle cage (ø22xø28x18 mm)	Cage à aiguilles (ø22xø28x18 mm)	Nadelkaefig (ø22xø28x18 mm)	Jaula de agujas del cojinete (ø22xø28x18 mm)	
	3	8000 72884	1	Pattino catena	Chain slider	Glissière	Gleitbahn	Plato cadena	
	4	8000 71621	2	Bussola	Bushing	Douille	Buchse	Manguito	
	5	8000 69282	1	Bussola	Bushing	Douille	Buchse	Manguito	
	6	8000 74815	2	Tendicatena	Chain adjuster	Tendeur de chaine	Kettenspanner	Tensor de cadena	
	7	8000 36137	3	Rosetta	Washer	Rondelle	Scheibe	Arandela	
	8	8000 75166	3	Scodellino anteriore	Front cup	Cuvette avant	Vorderteller	Cubeta delantera	
	8	8000 59289	1	Scodellino posteriore	Rear cup	Cuvette arriere	Hinterteller	Cubeta trasera	
	9	8000 40720	1	Dado	Nut	Ecrou	Mutter	Tuerca	
	10	8000 62795	1	Vite	Screw	Vis	Schraube	Tornillo	
	11	8A00 66661	2	Bussola	Bushing	Douille	Buchse	Manguito	
	12	8000 61313	2	Dado	Nut	Ecrou	Mutter	Tuerca	
	13	8000 71620	1	Perno forcellone	Fork pin	Pivot fourche	Gabelbolzen	Perno horquilla	
	14	8000 67997	1	Vite	Screw	Vis	Schraube	Tornillo	
	15	80A0 73456	1	Guidacavo	Cable guide	Guide câble	Kabelführung	Guía-cable	
	16	8AB0 76028	1	Copricatena	Chain guard	Carter de chaine	Kettenkasten	Cubrecadena	
	17	8A00 36984	1	Bussola	Bushing	Douille	Buchse	Manguito	
	18	1511 31701	1	Rullo	Roller	Aiguille	Rolle	Rodillo	
	19	8000 71623	1	Dado	Nut	Ecrou	Mutter	Tuerca	
	20	8000 62400	2	Vite	Screw	Vis	Schraube	Tornillo	
	21	8000 74816	2	Coperchietto	Cover	Couvercle	Deckel	Tapa	
	22	80A0 74388	1	Tappo	Plug	Bouchon	Verschluss	Tapón	
	23	8C00 67997	3	Vite	Screw	Vis	Schraube	Tornillo	
	24	8000 59289	1	Scodellino	Cup	Cuvette	Teller	Cubeta	
	25	8000 20536	1	Vite	Screw	Vis	Schraube	Tornillo	
	26	8A00 69282	2	Bussola	Bushing	Douille	Buchse	Manguito	
	27	8000 76002	2	Piastra d'attacco	Plate	Plaque	Platte	Placa	
	28	8000 72874	1	Guidacatena	Chain guide	Guide-chaine	Kettenführung	Guía-cadena	
	29	8E00 67545	2	Vite	Screw	Vis	Schraube	Tornillo	
	30	8000 32388	1	Rosetta	Washer	Rondelle	Scheibe	Arandela	
	31	8A00 20182	1	Distanziale	Spacer	Entretoise	Distanzstück	Separador	

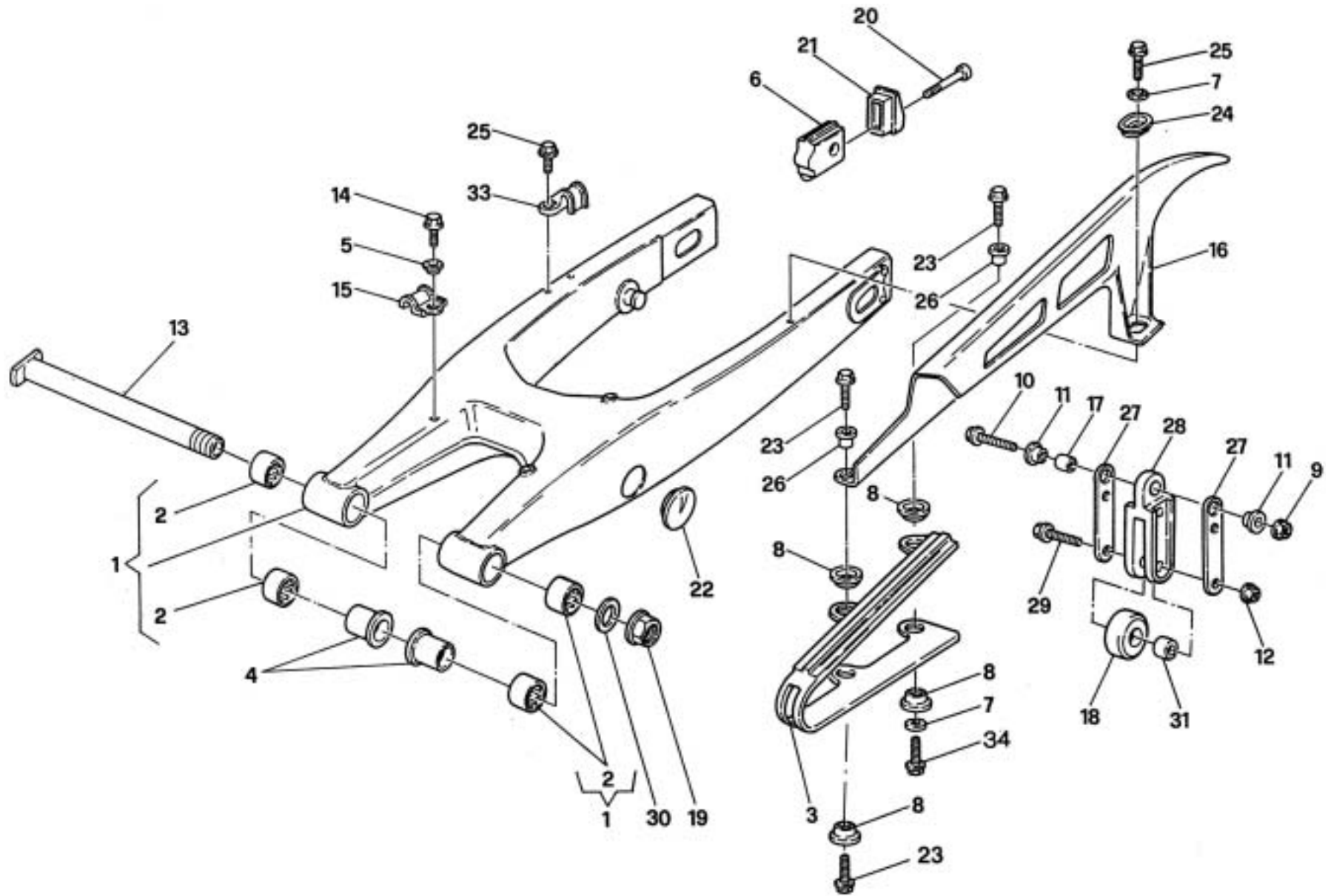



Note Notes Marke Notas	Pos. No. N. Index Pos.	N. Cod. Code No. Nr. Code Code Nr N. Cod.	Q.tà Q.ty Q.te M.ge C.ad	DENOMINAZIONE	NAME	DESIGNATION	BESHREIBUNG	DENOMINACION	Validità Validity Validité Gültig Validez
	33	80A0 59299	1	Fermatubo posteriore	Cable guide	Guide câble	Kabelführung	Guía-cable	
	34	8A00 67997	1	Vite	Screw	Vis	Schraube	Tornillo	

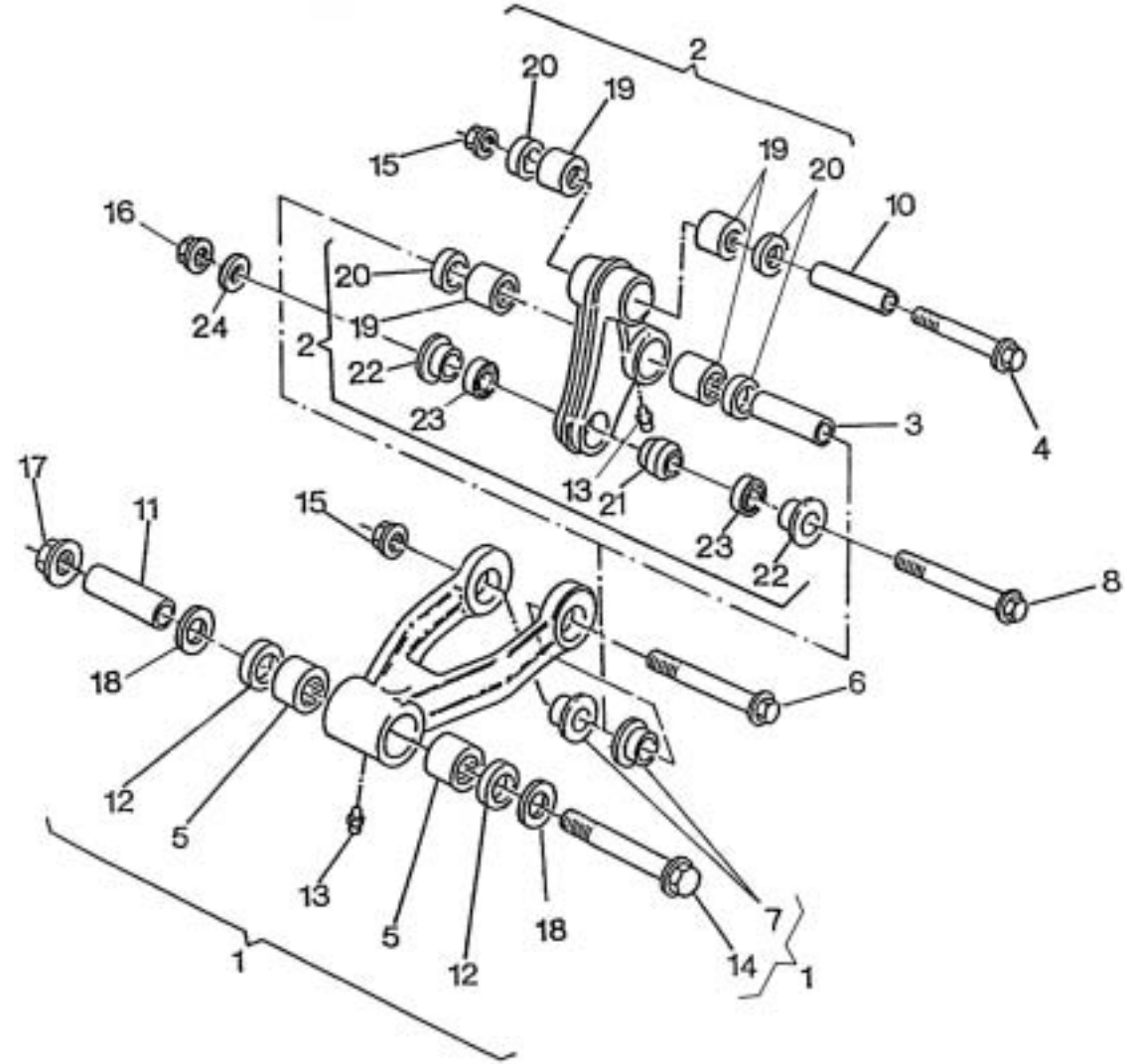

Note Notes Marke Notas	Pos. No. Index Pos.	N. Cod. Code No. Nr. Code Code Nr N. Cod.	Q.tà Q.ty Q.te M.ge C.ad	DENOMINAZIONE	NAME	DESIGNATION	BESHREIBUNG	DENOMINACION	Validità Validity Validité Gültig Validez
	1	8D00 68157	1	Tirante completo	Tie rod	Tirant	Spannstange	Tirante	
	2	8000 73348	1	Assieme bilanciare	Rocking lever assy	Balancier compl.	Schwinge Kpl.	Balancines compl.	
	3	8A00 75153	1	Spinotto	Gudgeon	Axe	Bolzen	Perno	
	4	8A00 74372	1	Perno (M12x80 mm)	Pin (M12x80 mm)	Pivot (M12x80 mm)	Bolzen (M12x80 mm)	Perno (M12x80 mm)	
	5	8000 38956	2	Boccola a rullini	Rollenbush	Douille rouleaux	Rollerbuchse	Casquillo	
	6	8000 74372	1	Perno (M12x160 mm)	Pin (M12x160 mm)	Pivot (M12x160 mm)	Bolzen (M12x160 mm)	Perno (M12x160mm)	
	7	8B00 42029	2	Bussola	Bushing	Douille	Buchse	Manguito	
	8	8A00 62797	1	Perno (M10x50 mm)	Pin (M10x50 mm)	Pivot (M10x50 mm)	Bolzen (M10x50 mm)	Perno (M10x50 mm)	
	10	8A00 75153	1	Spinotto	Gudgeon	Axe	Bolzen	Perno	
	11	8000 59839	1	Spinotto	Gudgeon	Axe	Bolzen	Perno	
	12	8000 38957	2	Anello di tenuta	Seal ring	Bague d'étanchéité	Dichtungsring	Anillo de retención	
	13	8000 01412	2	Ingrassatore	Lubricator	Graisseur	Schmierbüchse	Lubricador	
	14	8A00 69138	1	Perno (M10x75 mm)	Pin (M10x75 mm)	Pivot (M10x75 mm)	Bolzen (M10x75 mm)	Perno (M10x75 mm)	
	15	8000 40724	2	Dado	Nut	Ecrou	Mutter	Tuerca	
	16	8000 42022	1	Dado	Nut	Ecrou	Mutter	.Tuerca	
	17	8000 40722	1	Dado	Nut	Ecrou	Mutter	.Tuerca	
	18	8000 73394	2	Anello di spugna	Ring	Bague	Ring	Anillo	
	19	8000 42781	4	Boccola a rullini (ø20xø26x20 mm)	Rollenbush (ø20xø26x20 mm)	Douille rouleaux (ø20xø26x20 mm)	Rollerbuchse (ø20xø26x20 mm)	Casquillo (ø20xø26x20 mm)	
	20	8000 32065	4	Anello di tenuta (ø20xø26x4 mm)	Seal ring (ø20xø26x4 mm)	Bague d'étanchéité (ø20xø26x4 mm)	Dichtungsring (ø20xø26x4 mm)	Anillo de retención (ø20xø26x4 mm)	
	21	8000 72168	1	Snodo a sfera	Ball joint	Joint a rotule	Kugelgelenk	Articulacion esferica	
	22	1511 33302	2	Bussola	Bushing	Douille	Buchse	Manguito	
	23	8000 38767	2	Anello di tenuta	Seal ring	Bague d'étanchéité	Dichtungsring	Anillo de retención	
	24	8AA0 36237	1	Rosetta	Washer	Rondelle	Scheibe	Arandela	

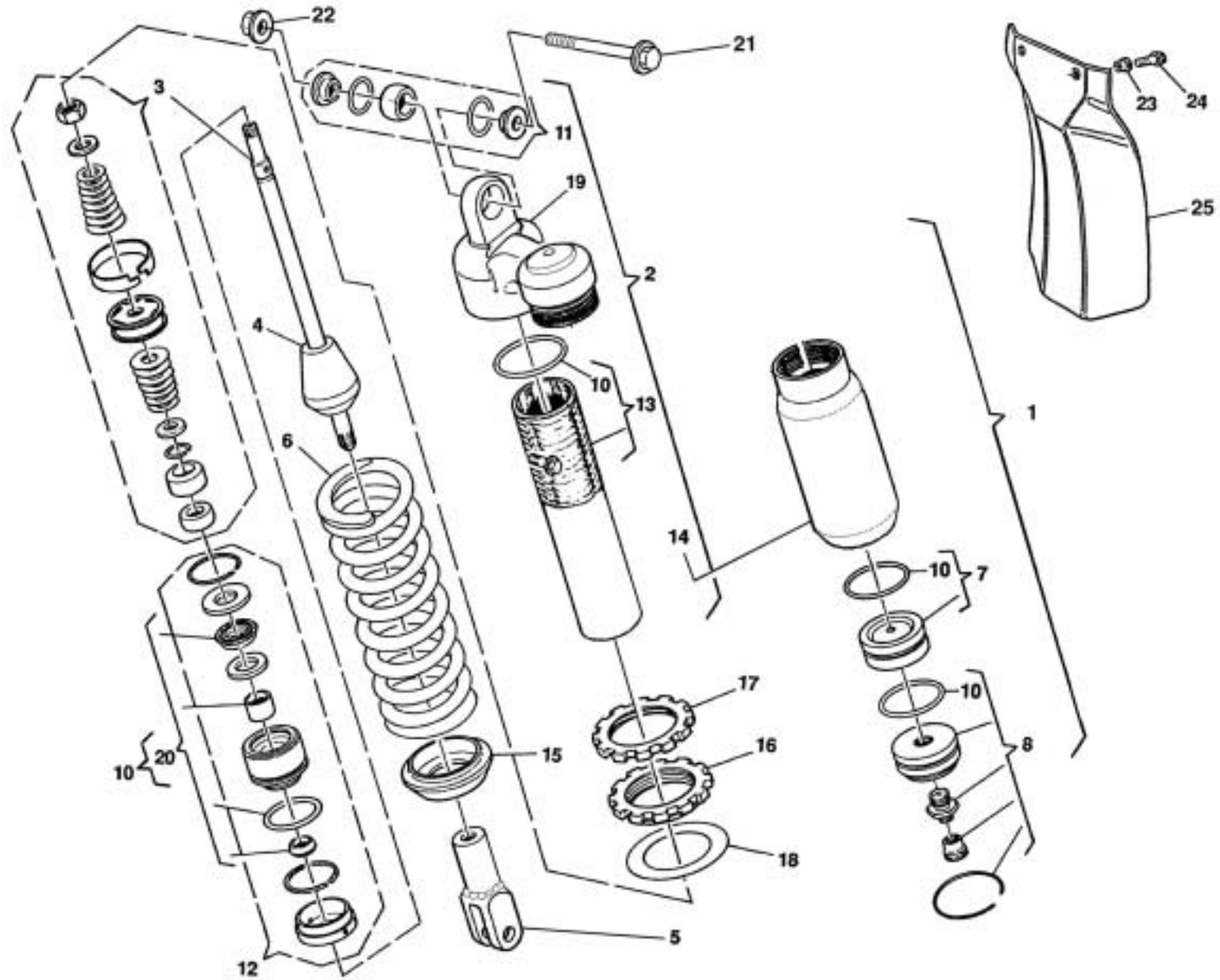

Note Notes Notes Marke Notas	Pos. No. N. Index Pos.	N. Cod. Code No. Nr. Code Code Nr N. Cod.	Q.tà Q.ty Q.te M.ge C.ad	DENOMINAZIONE	NAME	DESIGNATION	BESHREIBUNG	DENOMINACION	Validità Validity Validité Gültig Validez
W	1	8000 95008	1	Ammortizzatore completo	Shock-absorber	Ammortisseur	Stossdampfer	Amortigüador	
S	1	8A00 95008	1	Ammortizzatore completo	Shock-absorber	Ammortisseur	Stossdampfer	Amortigüador	
	2	8000 91862	1	Gruppo corpo	Damper case assy	Groupe corps ammortisseur	Stossdämpferkörper Kpl.	Corpo amortigüador compl.	
	3	8000 95895	1	Gruppo stelo	Rod assy	Groupe tige	Pumpenstückgruppe	Grupo espiga	
	4	8000 91864	1	Tampone	Pad	Tampon	Stopfen	Tampón	
	5	8000 91865	1	Gruppo forcella	Fork assy	Groupe fourche	Gabelgruppe Kpl.	Grupo horquilla	
	6	8AA0 79083	1	Molla	Spring	Ressort	Feder	Resorte	
	7	8000 89085	1	Diaframma	Diaphragm	Diaphragme	Biegeplatte	Diafragma	
	8	8000 89086	1	Gruppo serbatoio	Tank assy	Groupe reservoir	Tankgruppe Kpl.	Grupo deposito compl.	
	10	8000 95891	1	Gruppo guarnizioni	Gasket set	Groupe garnitures	Dichtungssatz	Grupo juntas	
	11	8000 91856	1	Gruppo snodo	Ball joint assy	Groupe joint a rotule	Kugelgelenkgruppe Kpl.	Grupo articulaciön esférica	
	12	8000 95892	1	Gruppo guida stelo	Guide rod assy	Groupe guide tige	Pumpenstückführunggr.	Grupo guja espiga	
	13	8000 91869	1	Corpo ammortizzatore	Damper case	Corps ammortisseur	Stossdämpferkörper	Corpo amortigüador	
	14	8000 91870	1	Serbatoio	Tank	Reservoir	Tank	Deposito	
	15	8000 91871	1	Fondello	Bottom	Fond	Bodenscheibe	Casquillo	
	16	8000 89097	1	Ghiera	Ring nut	Embout	Nutmutter	Virola	
	17	8000 89098	1	Ghiera	Ring nut	Embout	Nutmutter	Virola	
	18	8000 89099	1	Rosetta per molla	Washer	Rondelle	Scheibe	Arandela	
	19	8000 91872	1	Supporto serbatoio	Tank support	Support reservoir	Gastankhalterung	Soporte deposito	
	20	8000 91861	1	Gruppo guarnizioni per stelo	Rod gasket set	Jeu joints pour tige	Dichtungssatz	Serie juntas por espiga	
	21	8A00 62797	1	Vite (M10x50 mm)	Screw (M10x50 mm)	Vis (M10x50 mm)	Schraube (M10x50 mm)	Tornillo (M10x50 mm)	
	22	8000 42022	1	Dado	Nut	Ecrou	Mutter	Tuerca	
	23	8000 69429	2	Bussola	Bushing	Douille	Buchse	Manguito	
	24	8000 62726	2	Vite	Screw	Vis	Schraube	Tornillo	
	25	80A0 69551	1	Protezione ammortizzatore	Guard	Protection	Schutz	Protección	

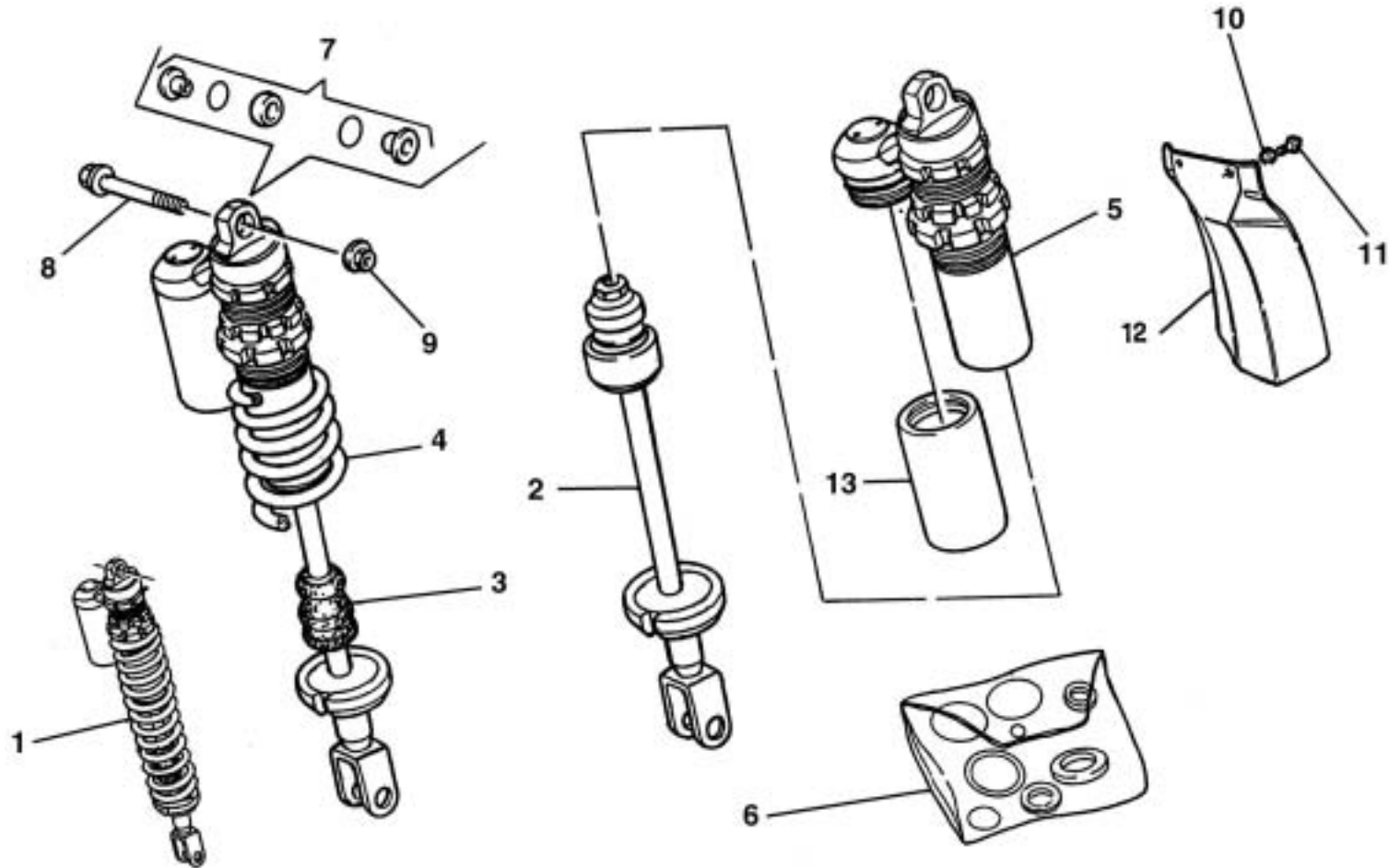

Note Notes Notes Marke Notas	Pos. No. N. Index Pos.	N. Cod. Code No. Nr. Code Code Nr N. Cod.	Q.tà Q.ty Q.te M.ge C.ad	DENOMINAZIONE	NAME	DESIGNATION	BESHREIBUNG	DENOMINACION	Validità Validity Validité Gültig Validez
	1	8000 94975	1	Ammortizzatore completo	Shock-absorber	Ammortisseur	Stossdämpfer	Amortigüador	
	2	8000 94971	1	Gruppo corpo	Damper case assy	Groupe corps amortisseur	Stossdämpferkörper Kpl.	Corpo amortigüador compl.	
	3	8000 94972	1	Tampone	Pad	Tampon	Stopfen	Tampón	
	4	8000 94973	1	Molla	Spring	Ressort	Feder	Resorte	
	5	8000 94970	1	Gruppo serbatoio	Tank assy	Groupe reservoir	Tankgruppe Kpl.	Grupo deposito compl.	
	6	8000 94974	1	Gruppo guarnizioni	Gasket set	Groupe garnitures	Dichtungssatz	Grupo juntas	
	7	8000 94968	1	Gruppo snodo	Ball joint assy	Groupe joint a rotule	Kugelgelenkgruppe Kpl.	Grupo articulaciön esferica	
	8	8A00 62797	1	Vite (M10x50 mm)	Screw (M10x50 mm)	Vis (M10x50 mm)	Schraube (M10x50 mm)	Tornillo (M10x50 mm)	
	9	8000 42022	1	Dado	Nut	Ecrou	Mutter	Tuerca	
	10	8000 69429	2	Bussola	Bushing	Douille	Buchse	Manguito	
	11	8000 62726	2	Vite	Screw	Vis	Schraube	Tornillo	
	12	80A0 69551	1	Protezione ammortizzatore	Guard	Protection	Schutz	Protección	
	13	8000 94969	1	Gruppo tappo	Plug	Bouchon	Verschluss	Tapòn	

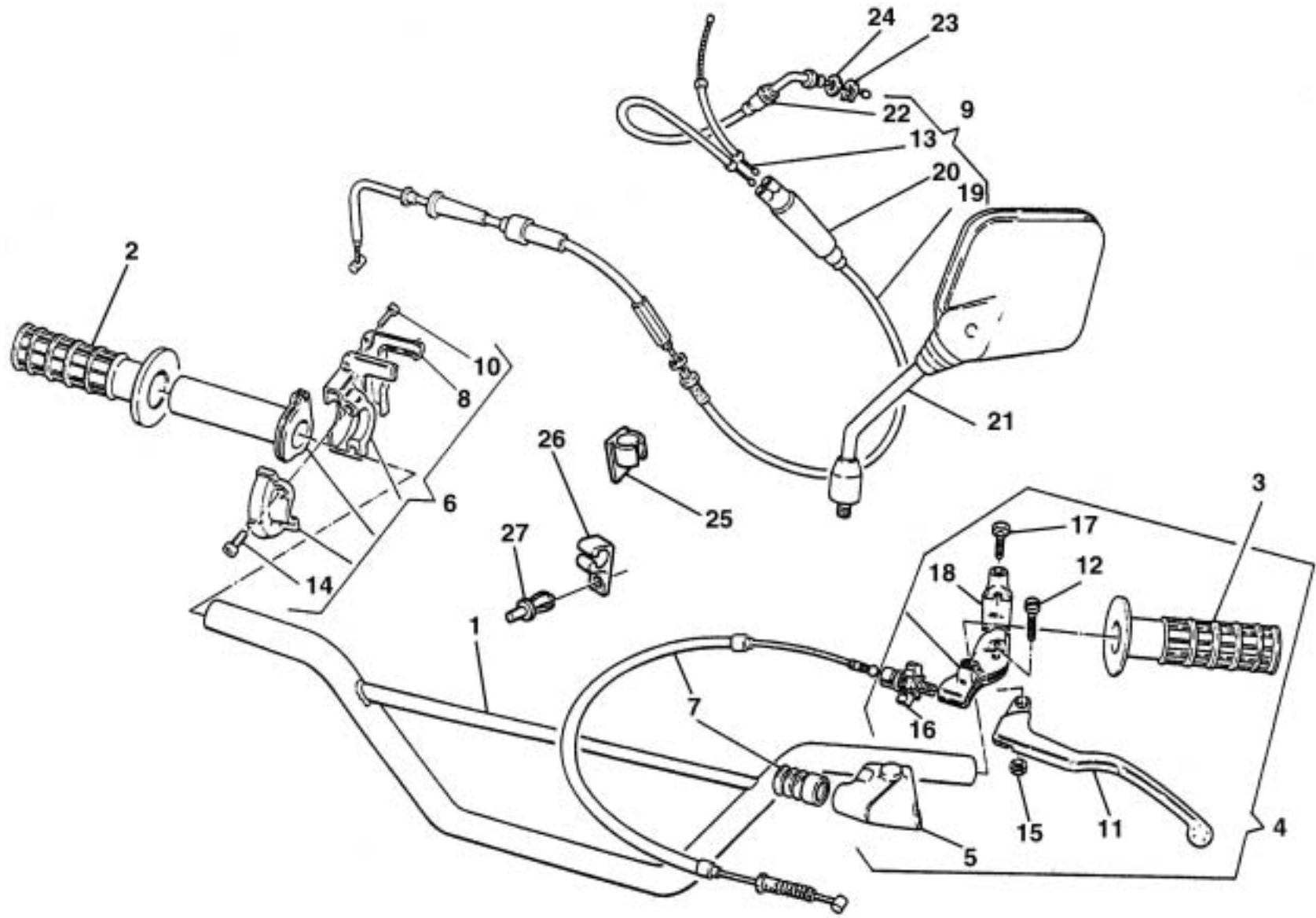

Note Notes Marke Notas	Pos. No. N. Index Pos.	N. Cod. Code No. Nr. Code Code Nr N. Cod.	Q.tà Q.ty Q.te M.ge C.ad	DENOMINAZIONE	NAME	DESIGNATION	BESHREIBUNG	DENOMINACION	Validità Validity Validité Gültig Validez
	1	8A00 92301	1	Manubrio	Hanblebar	Guidon	Lenker	Manillar	
	2	8000 76688	1	Manopola destra	R.H. grip	Poignée G.	Griff R.	Manopla der.	
	3	8000 76687	1	Manopola sinistra	L.H. grip	Poignée G.	Griff L.	Manopla izq.	
	4	8000 77736	1	Com. frizione completo	Clutch trasm. assy	Trasm. embrayage compl.	Führungssteuerung	Mando embrague compl.	
	5	8000 48917	1	Coprileva	Lever cover	Couvre levier	Hebeldeckel	Cubre-palanca	
	6	8000 75271	1	Comando gas completo	Throttle control compl.	Commande gaz compl.	Gasgriff kpl.	Accionam. acelerador com.	
	7	8000 92817	1	Trasmissione com. frizione	Clutch transm.	Transm. com. embrayage	Führungssteuerung	Trans. mando embrague com.	
	8	8000 75310	1	Coperchietto	Cover	Couvercle	Deckel	Tapa	
	9	8A00 76023	1	Trasmissione gas	Throttle trasm.	Trasm. comm. gaz	Führungsteuerung des Gases	Tran.mando acelerador compl.	
	10	8000 66774	2	Vite	Screw	Vis	Schraube	Tornillo	
	11	8000 77737	1	Leva comando frizione	Clutch lever	Levier embrayage	Kupplungshebel	Palanca mando embrague	
	12	8000 38797	1	Vite	Screw	Vis	Schraube	Tornillo	
	13	8B00 56707	1	Trasmissione carburatore	Wire	Fil	Kabel	Transmission	
	14	60N1 07330	2	Vite	Screw	Vis	Schraube	Tornillo	
	15	8000 38799	1	Dado	Nut	Ecrou	Mutter	Tuerca	
	16	8000 48916	1	Gruppo registro	Adjuster set	Groupe reglage	Kupplungsreglergruppe	Grupo regul.	
	17	8000 62729	2	Vite	Screw	Vis	Schraube	Tornillo	
	18	8000 77735	1	Cavallotto	U-bolt	Cavalier	Bügelbolzen	Caballote	
	19	8A00 76774	1	Trasmissione gas e pompa olio	Throttle and oil pump wire	Fil comm. gaz et pompe huile	Gassteuerung u.Ölpumpenkabel	Tran.acelerador-bomba aceite	
	20	8000 21198	1	Astuccio sdoppiatore	Cables cage	Etui fils	Kabeltasche	Estuche	
D	21	8000 58378	1	Specchio retrovisore compl.	Driving mirror	Rétroviseur	Rückspiegel	Espejo retrovisor	
	22	8B00 68570	1	Trasmissione compl.pompa olio	Throttle and oil pump	Trasm. compl. pompe huile	Oelppumpenkabel	Tran. compl.bomba aceite	
	23	66N0 21309	1	Anello elastico	Split ring	Anneau ressort	Sprengring	Anillo elastico	
	24	8000 09721	1	Rosetta	Washer	Rondelle	Scheibe	Arandela	
	25	8000 61068	1	Molletta guidatrasmissioni	Cable guide	Guide câble	Kabelführung	Guja cable	
	26	8000 85220	1	Molletta guidatrasmissioni	Cable guide	Guide câble	Kabelführung	Guja cable	
	27	8000 48966	1	Rivetto	Rivet	Rivet	Niet	Remache	

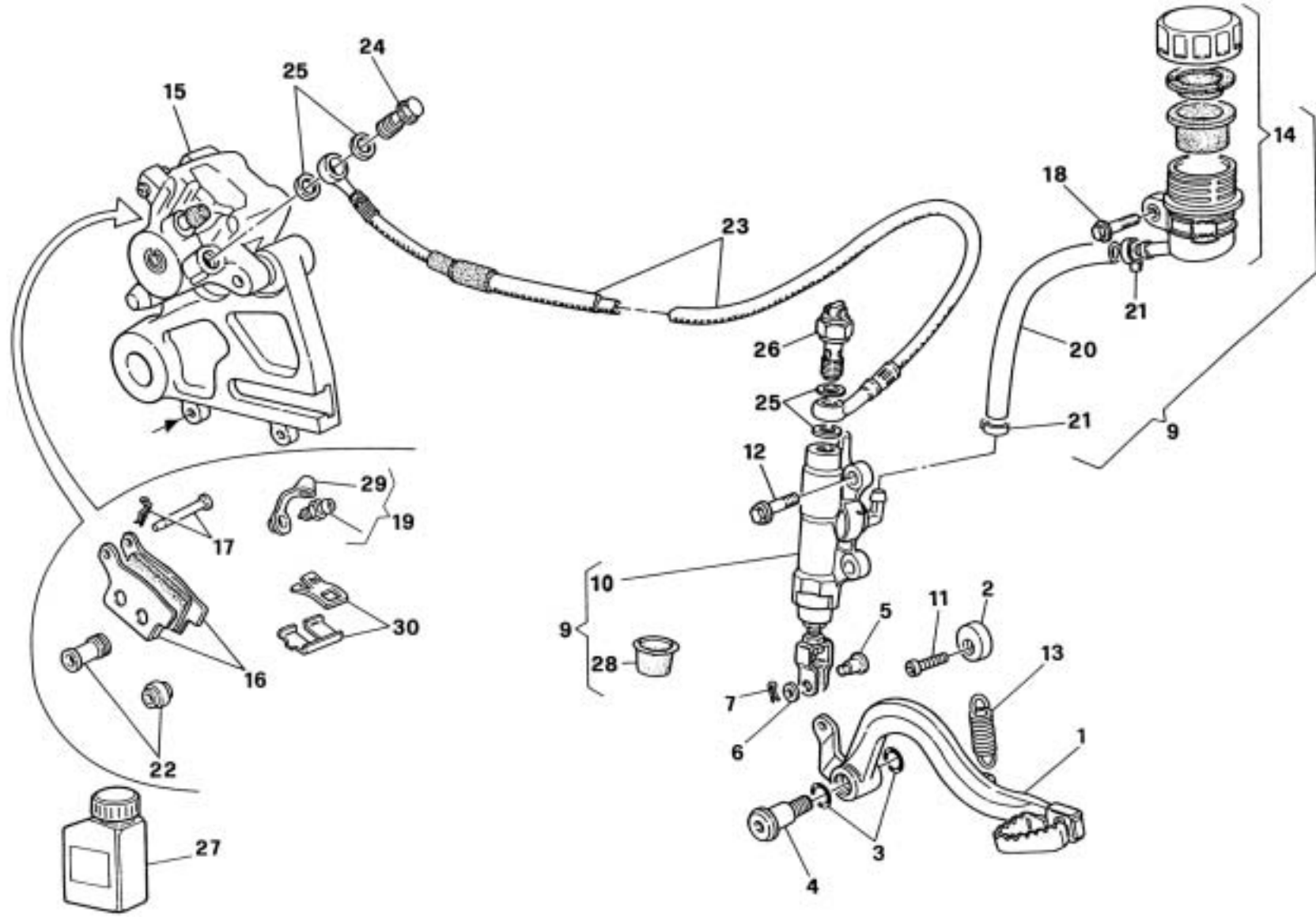



wre 125 dual purpose
sm 125 s / 2004

TAVOLA
DRAWING
TABLE
BILD
TABLA

18

FRENO IDRAULICO POSTERIORE - REAR HYDRAULIC BRAKE
FREIN HYDRAULIQUE ARRIERE - HINTERBREMSE
FRENO HIDRAULICO TRASERO

Note Notes Notes Marke Notas	Pos. No. N. Index Pos.	N. Cod. Code No. Nr. Code Code Nr N. Cod.	Q.tà Q.ty Q.te M.ge C.ad	DENOMINAZIONE	NAME	DESIGNATION	BESHREIBUNG	DENOMINACION	Validità Validity Validité Gültig Validez
	1	8000 73894	1	Leva comando freno	Brake control lever	Levier comm. frein	Bremshebel	Palanca accionamiento freno	
	2	8000 69125	1	Camma	Cam	Came	Nocken	Exéntrico	
	3	8000 22551	2	Anello OR	O-Ring	Bague OR	O-Ring	Anillo OR	
	4	8000 55902	1	Vite	Screw	Vis	Schraube	Tornillo	
	5	8000 70696	1	Perno	Pin	Pivot	Bolzen	Perno	
	6	8000 56377	1	Rosetta	Washer	Rondelle	Scheibe	Arandela	
	7	64N1 20068	1	Copiglia	Split pin	Goupille	Splint	Clavija	
	9	8000 76026	1	Pompa comando freno compl.	Brake pump aaassy	Pompe frein complet	Bremspumpe kl.	Bomba freno compl.	
	10	8000 76338	1	Pompa freno	Brake pump	Pompe frein	Bremspumpe	Bomba freno	
	11	8A00 55241	1	Vite	Screw	Vis	Schraube	Tornillo	
	12	8000 62726	2	Vite	Screw	Vis	Schraube	Tornillo	
	13	8A00 55903	1	Molla	Spring	Ressort	Feder	Resorte	
	14	8000 61078	1	Serbatoio olio completo	Oil tank assy	Reservoir huile compl.	Öltank Kpl.	Depósito aceite completo	
	15	8000 76032	1	Pinza freno completa	Brake caliper assy	Pince de frein, compl.	Bremszange, Kpl.	Pinza freno compl.	
	16	8000 79072	1	Coppia pastiglie	Pads pair	Paire plaquettes	Bremsbelagpaar	Pareja pastillas	
	17	8000 87152	1	Perno	Pin	Pivot	Bolzen	Perno	
	18	8000 62725	1	Vite	Screw	Vis	Schraube	Tornillo	
	19	8000 60404	1	Spurgo	Spurgo	Drain	Entleerung	Purga	
	20	8C00 70266	1	Tubazione	Pipe	Tuyau	Rohr	Tubo	
	21	8000 42349	2	Molletta	Spring	Ressort	Feder	Resorte	
	22	8000 79066	1	Cuffia	Boots	Poussiers	haube	Gorro	
	23	8000 78164	1	Tubo mandata olio	Pipe	Tuyau	Rohr	Tubo	
	24	8000 57155	1	Vite	Screw	Vis	Schraube	Tornillo	
	25	8000 21480	4	Rosetta ondulata	Washer	Rondelle	Scheibe	Arandela	
	26	8000 37891	1	Interruttore stop posteriore	Stop switch	Interrupteur stop	Stopschalter	Interruptor stop	
R	27	8000 71445	1	Olio freni	Brake oil	Huile de frein	BremsÖl	Aceite freno	
	28	8000 79075	1	Cuffia	Boot	Poussier	haube	Gorro	
	29	8000 53259	1	Parapolvere	Boots	Para-poudre	Schutzhaube	Para-polvo	
	30	8000 85932	1	Molla-lamierino	Spring-steel clip	Ressort	Feder	Rresorte	

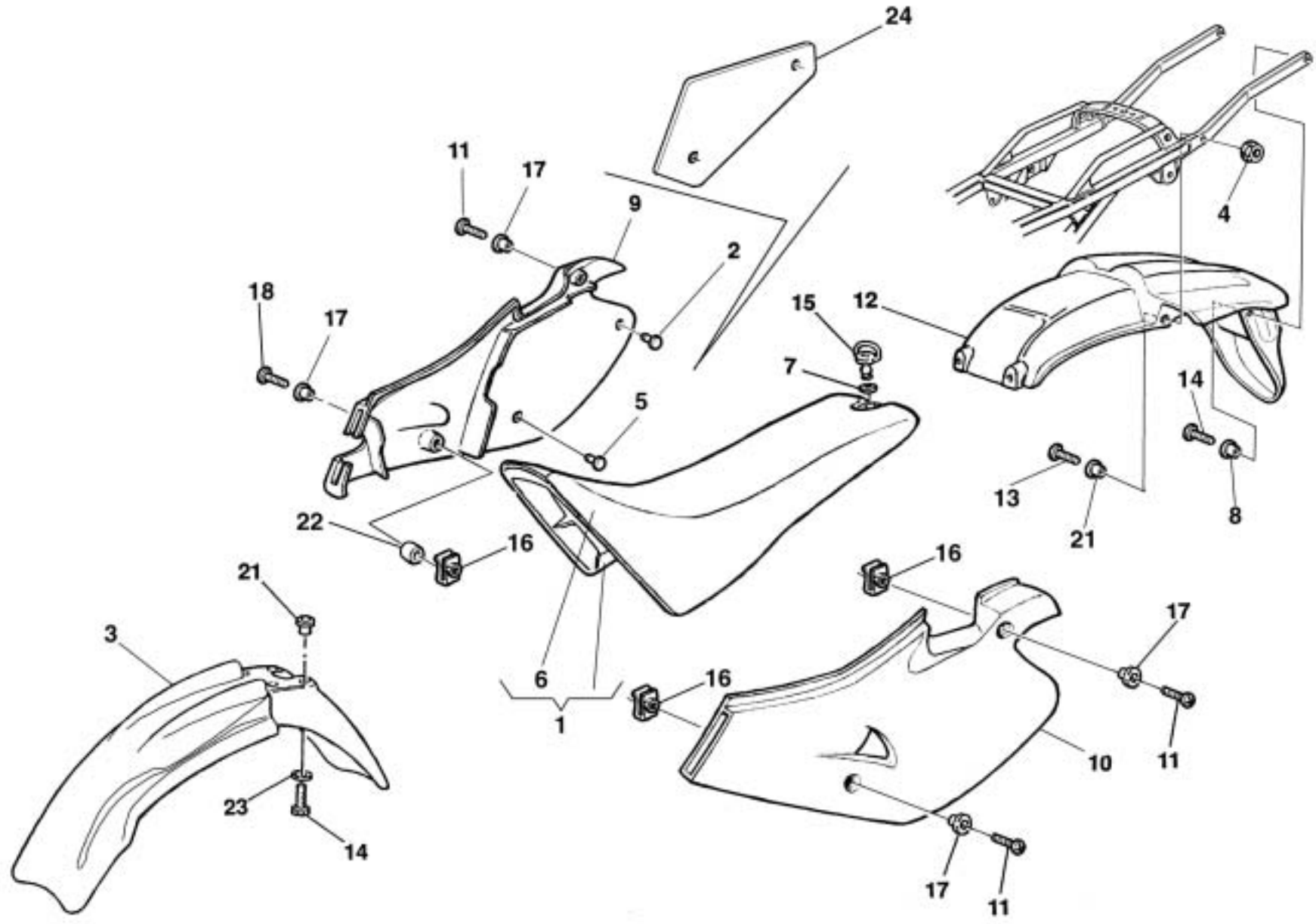



wre 125 dual purpose
sm 125 s / 2004

TAVOLA
DRAWING
TABLE
BILD
TABLA

19

PANNELLI LATERALI, PARAFANGHI, SELLA - SIDE PANEL, FENDERS, SEAT
PANNEAU, GARDE-BOUES, SIEGE - STREIFEN, KOTFLUGEL, SATTEL
PANELES, GUARDABARROS, SILLIN

Note Notes Notes Marke Notas	Pos. No. N. Index Pos.	N. Cod. Code No. Nr. Code Code Nr N. Cod.	Q.tà Q.ty Q.te M.ge C.ad	DENOMINAZIONE	NAME	DESIGNATION	BESHREIBUNG	DENOMINACION	Validità Validity Validité Gültig Validez
WS	1	8B00 A0050	1	Sella (cod. col. E)	Seat (col.code E)	Siège (code col. E)	Sattel (Code Farbe E)	Sillín (cod. col. E)	
S	1	8A00 A0050	1	Sella (cod. col. G)	Seat (col.code G)	Siège (code col. G)	Sattel (Code Farbe G)	Sillín (cod. col. G)	
	2	8000 45042	1	Gommino anticalore	Rubber pad	Pièce caoutchouc	Gummistück	Junta de goma	
WS	3	80F0 87059	1	Parafango ant. (cod. col. E)	Front mudguard (col. cod. E)	Garde-boue avant (cod.col. E)	Vord. Kotfluegel (C. Farbe E)	Guarda-barros del. (c.col. E)	
S	3	80G0 87059	1	Parafango ant. (cod. col. G)	Front mudguard (col. cod. G)	Garde-boue avant (cod.col. G)	Vord. Kotfluegel (C. Farbe G)	Guarda-barros del. (c. col. G)	
	4	8000 61313	2	Dado	Nut	Ecrou	Mutter	Tuerca	
	5	8000 48802	1	Gommino anticalore	Rubber pad	Pièce caoutchouc	Gummistück	Junta de goma	
WS	6	8000 A0051	1	Rivestimento sella (cod. col. E)	Saddle cover. (col.code E)	Revel. selle (code col. E)	Sattelverkleid. (C. Farbe E)	Rev. sillín (cod. col. E)	
S	6	8A00 A0051	1	Rivestimento sella (cod. col. G)	Saddle cover. (col.code G)	Revel. selle (code col. G)	Sattelverkleid. (C. Farbe G)	Rev. sillín (cod. col. G)	
	7	8000 69149	1	Rosetta elastica	Spring washer	Rondelle élastique	Federscheibe	Arandela elástica	
	8	8000 45495	1	Bussola	Bushing	Douille	Buchse	Casquillo	
WS	9	8AB0 88866	1	Pannello destro (cod. col. E)	R.H. panel (col. cod. E)	Panneau, D. (cod. col. E)	Streifen. R. (Cod. Farbe E)	Panel der. (cod. col. E)	
S	9	8AA0 88866	1	Pannello destro (cod. col. G)	R.H. panel (col. cod. G)	Panneau, D. (cod. col. G)	Streifen. R. (Cod. Farbe G)	Panel der. (cod. col. G)	
WS	10	8AB0 88867	1	Pannello sinistro (cod. col. E)	L.H. panel (col. cod. E)	Panneau, G. (cod. col. E)	Streifen. L. (Cod. Farbe E)	Panel izq. (cod. col. E)	
S	10	8AA0 88867	1	Pannello sinistro (cod. col. G)	L.H. panel (col. cod. G)	Panneau, G. (cod. col. G)	Streifen. L. (Cod. Farbe G)	Panel izq. (cod. col. G)	
	11	8000 62728	4	Vite	Screw	Vis	Schraube	Tornillo	
WS	12	8000 A0545	1	Parafango poster. (cod. col. E)	Rear mudguard (col. cod. E)	Gardeboue arriere (col.cod. E)	Hint. Kotfluegel (C. Farbe E)	Guarda-barros tra.(c. col. E)	
S	12	8CA0 A0545	1	Parafango poster. (cod. col. G)	Rear mudguard (col. cod. G)	Gardeboue arriere (cod.col. G)	Hint. Kotfluegel (C. Farbe G)	Guarda-barros tra.(c. col. G)	
	13	8000 62728	2	Vite	Screw	Vis	Schraube	Tornillo	
	14	8000 62726	2	Vite	Screw	Vis	Schraube	Tornillo	
	15	8000 69148	1	Perno	Pin	Pivot	Bolzen	Perno	
	16	8000 46893	2	Dado	Nut	Ecrou	Mutter	Tuerca	
	17	8000 69429	4	Boccola	Bushing	Douille	Buchse	Casquillo	
	18	8000 62729	1	Vite	Screw	Vis	Schraube	Tornillo	
	21	8000 69429	2	Bussola	Bushing	Douille	Buchse	Manguito	
	22	8B00 81884	4	Distanziale	Spacer	Entretoise	Distanzstück	Separador	
	23	8000 48814	4	Rosetta	Washer	Rondelle	Scheibe	Arandela	
	24	8000 95727	1	Protezione	Guard	Protection	Schutz	Protección	

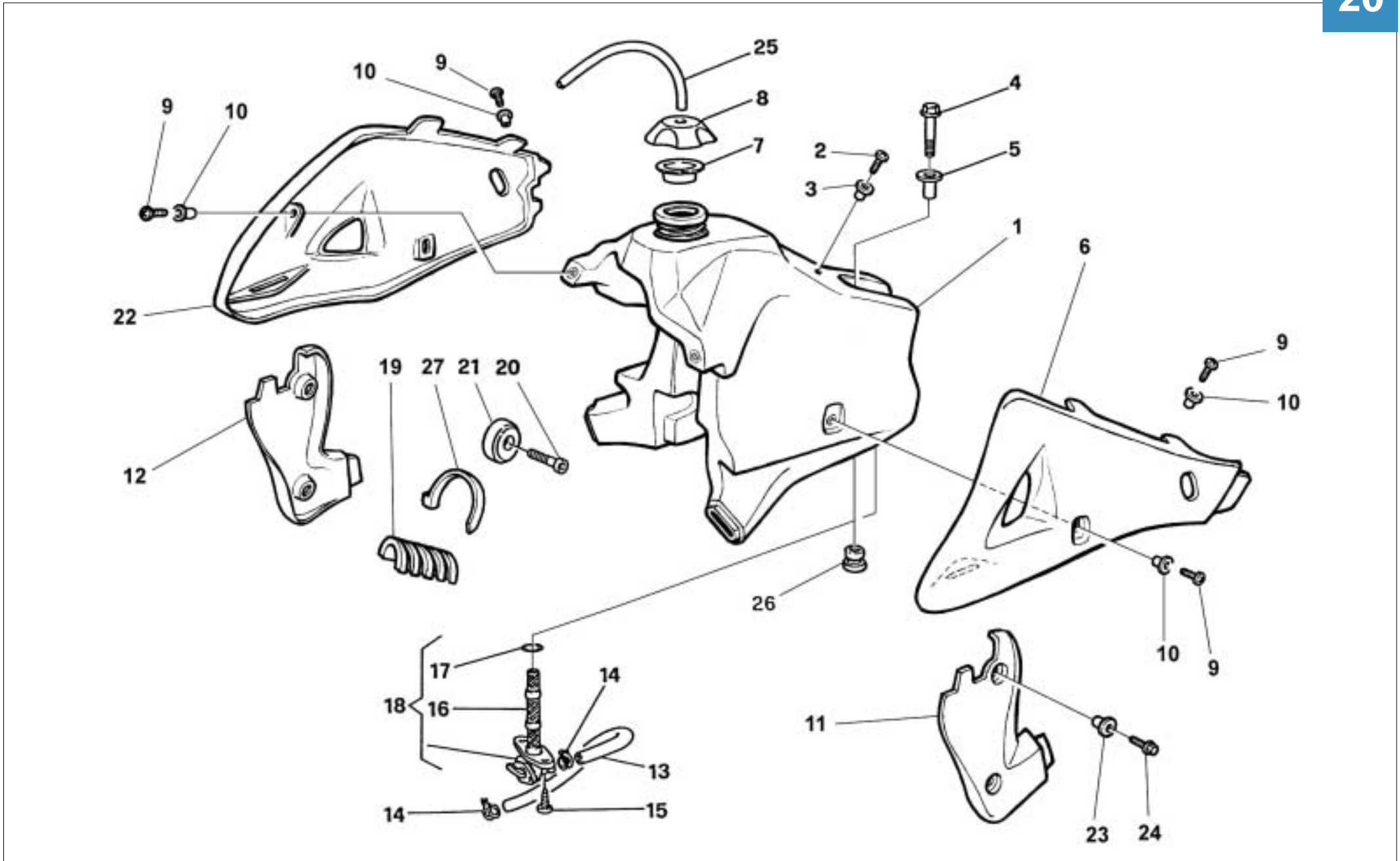



wre 125 dual purpose
sm 125 s / 2004

TAVOLA
DRAWING
TABLE
BILD
TABLA

20

SERBATOIO/ CONVOGLIATORI- GAS TANK/ PANEL
RESERVOIR/ FLANC - KRAFTSTOFFBEHALTER/ FLANKE
DEPOSITO/ LATERAL

Note Notes Marke Notas	Pos. No. N. Index Pos.	N. Cod. Code No. Nr. Code Code Nr N. Cod.	Q.tà Q.ty Q.te M.ge C.ad	DENOMINAZIONE	NAME	DESIGNATION	BESHREIBUNG	DENOMINACION	Validità Validity Validité Gültig Validez
	1	8000 88862	1	Serbatoio carburante (I 11,2)	Fuel tank (I 11,2)	Réservoir carburant (I 11,2)	Überdimensionierttank (I 11,2)	Depósito gasolina (I 11,2)	
	2	60N1 04134	1	Vite	Screw	Vis	Schraube	Tornillo	
	3	8000 66238	1	Distanziale	Spacer	Entretoise	Distanzstück	Separador	
	4	8A00 67545	1	Vite	Screw	Vis	Schraube	Tornillo	
	5	8000 69036	1	Distanziale	Spacer	Entretoise	Distanzstück	Separador	
WS	6	8AB0 88868	1	Convogliatore SX (cod. col. E)	L. side panel (cod. col. E)	Flanc G. (code col. E)	Flanke L. (Code Farbe E)	Lateral I. (cod. col. E)	
S	6	8AA0 88868	1	Convogliatore SX (cod. col. G)	L. side panel (col.code G)	Flanc G. (code col. G)	Flanke L. (Code Farbe G)	Lateral I. (cod. col. G)	
	7	8000 56381	1	Guarnizione	Gasket	GGarniture	Dichtung	Junta	
	8	8000 94098	1	Tappo	Plug	Bouchon	Verschluss	Tapón	
	9	8000 36467	8	Vite	Screw	Vis	Schraube	Tornillo	
	10	8000 45495	8	Bussola	Bushing	Douille	Buchse	Manguito	
	11	8000 93883	1	Protezione Sx	L.H. protection	Protection G.	Schutz Linke	Protección izquierda	
	12	8000 93017	1	Protezione Dx	R.H. protection	Protection D.	Schutz Rechte	Protección derecha	
	13	8000 94010	1	Condotto benzina	Pipe	Tuyau	Rohr	Tubo	
	14	80A0 42349	2	Fascetta	Split ring	Anneau ressort	Sprengring	Anillo elástico	
	15	8000 37745	2	Vite	Screw	Vis	Schraube	Tornillo	
	16	8000 38748	1	Filtro benzina	Fuel filter	Filtre essence	Benzinfilter	Filtro gasolina	
	17	8000 01199	1	Anello OR	O-Ring	Bague OR	O-Ring	Anillo OR	
	18	8000 43592	1	Rubinetto completo	Cock assy	Robinet compl.	Kraftstoffahn, Kpl.	Llave de paso compl.	
	19	8000 94009	1	Tampone	Pad	Tampon	Stopfen	Tampón	
	20	8000 41240	2	Vite	Screw	Vis	Schraube	Tornillo	
	21	8000 40813	1	Tampone	Pad	Tampon	Stopfen	Tampón	
WS	22	8AB0 88869	1	Convogliatore DX (cod. col. E)	R. side panel (cod. col. E)	Flanc D. (code col. E)	Flanke R. (Code Farbe E)	Lateral D. (cod. col. E)	
S	22	8AA0 88869	1	Convogliatore DX (cod. col. G)	R. side panel (col.code G)	Flanc D. (code col. G)	Flanke R. (Code Farbe G)	Lateral D. (cod. col. G)	
	23	8000 69429	4	Bussola	Bushing	Douille	Buchse	Manguito	
	24	8000 62727	4	Vite	Screw	Vis	Schraube	Tornillo	
	25	8S00 68873	1	Tubetto sfiato	Battery breather pipe	Event batterie	Batterieentlüfter	Tubo de purga batería	
	26	8000 69035	1	Gommino	Rubber pad	Pièce caoutchouc	Gummistück	Junta de goma	
	27	8000 50005	1	Fascetta	Split ring	Anneau ressort	Sprengring	Anillo elástico	

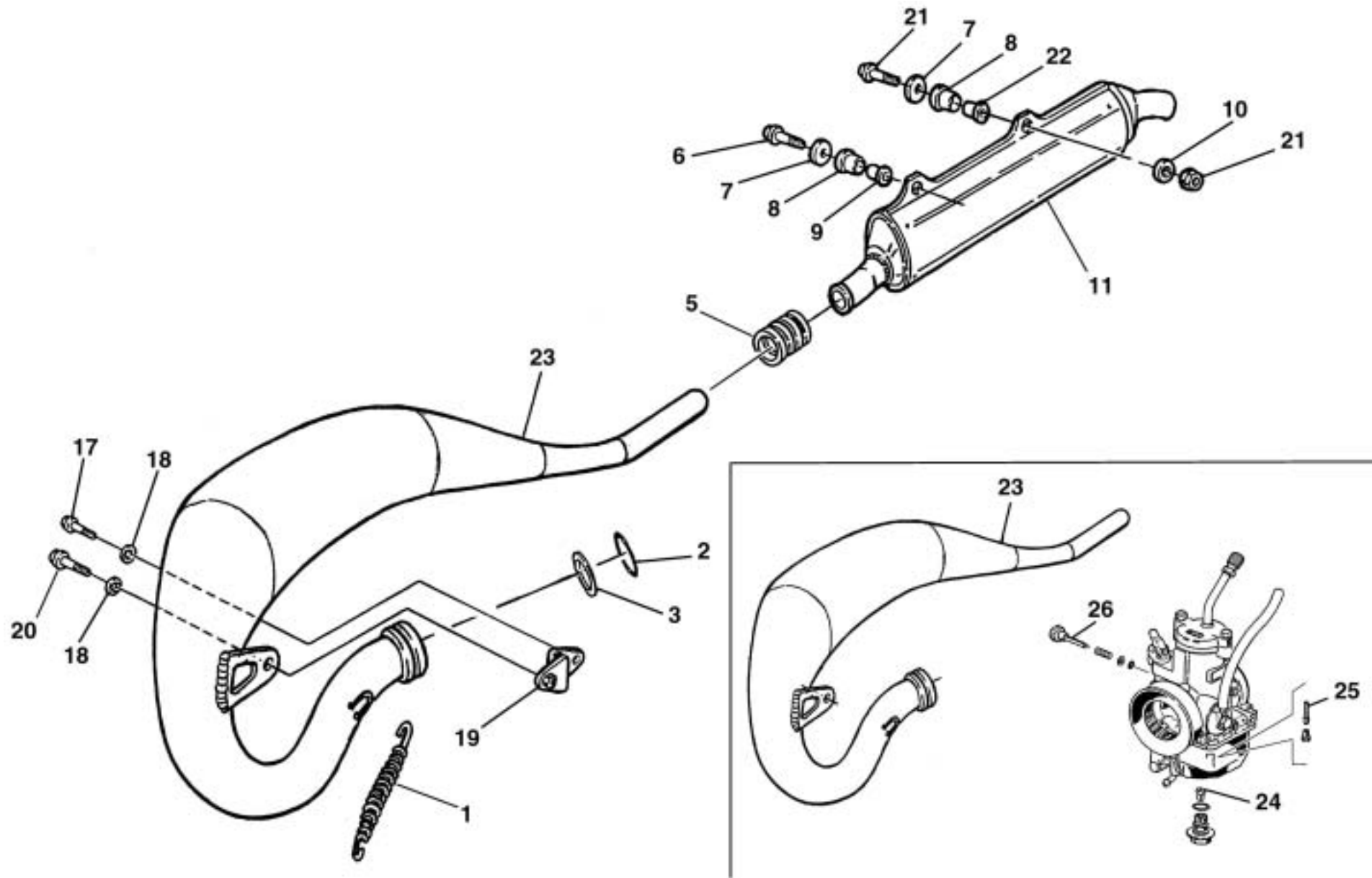



wre 125 dual purpose
sm 125 s / 2004

TAVOLA
DRAWING
TABLE
BILD
TABLA

21

SCARICO - EXHAUST SYSTEM
TUYAU D'ÉCHAPPEMENT - AUSPUFFROHR
TUBO DE ESCAPE

Note Notes Marke Notas	Pos. No. N. Index Pos.	N. Cod. Code No. Nr. Code Code Nr N. Cod.	Q.tà Q.ty Q.te M.ge C.ad	DENOMINAZIONE	NAME	DESIGNATION	BESHREIBUNG	DENOMINACION	Validità Validity Validité Gültig Validez
	1	8000 62341	2	Molla	Spring	Ressort	Feder	Resorte	
	2	8A00 23186	1	Anello OR	O-Ring	Bague OR	O-Ring	Anillo OR	
	3	8C00 73541	1	Rosetta	Washer	Rondelle	Scheibe	Arandela	
	5	8000 92788	1	Gommino	Rubber pad	Pièce caoutchouc	Gummistück	Junta de goma	
	6	8A00 67545	1	Vite	Screw	Vis	Schraube	Tornillo	
	7	1513 74301	1	Rosetta	Washer	Rondelle	Scheibe	Arandela	
	8	1514 10702	2	Gommino	Rubber pad	Pièce caoutchouc	Gummistück	Junta de goma	
	9	8B00 70379	1	Distanziale	Spacer	Entretoise	Distanzstück	Separador	
	10	1513 41401	2	Gommino	Rubber pad	Pièce caoutchouc	Gummistück	Junta de goma	
	11	8000 94808	1	Silenziatore	Exhaust silencer	Silencieux d'éch.	Schalldämpfer	Silenciador	
	17	8000 62725	1	Vite	Screw	Vis	Schraube	Tornillo	
	18	8000 45499	2	Rosetta piana	Washer	Rondelle	Scheibe	Arandela	
	19	8000 69113	1	Antivibrante	Silent-block	Antivibration	Schwingungsdämpfer	Anti-vibrador	
	20	8000 62726	1	Vite	Screw	Vis	Schraube	Tornillo	
	21	8A00 67545	1	Vite	Screw	Vis	Schraube	Tornillo	
	22	8D00 70379	1	Distanziale	Spacer	Entretoise	Distanzstück	Separador	
E	23	8000 94806	1	Tubo di scarico	Exhaust pipe	Tuyau d'échapp.	Auspuffrohr	Tubo de escape	
	23	8A00 94806	1	Tubo di scarico	Exhaust pipe	Tuyau d'échapp.	Auspuffrohr	Tubo de escape	
	23	8B00 94806	1	Tubo di scarico (senza catalizzatore)	Exhaust pipe (without catalyst)	Tuyau d'échapp. (sans catalyseur)	Auspuffrohr (ohne katalysator)	Tubo de escape (sin catalizador)	
F	23	8C00 94806	1	Tubo di scarico (tipo LIBERO)	Exhaust pipe (FREE Exhaust)	Tuyau d'échapp. (échappement LIBRE)	Auspuffrohr (FREI Auspuffrohr)	Tubo de escape (escape LIBRE)	
F	24	80G0 12041	1	Getto massimo (125)	Main jet (125)	Gicleur principal (125)	Hauptdüse (125)	Chiclé máximo (125)	
F	25	8B00 87148	1	Getto minimo (60)	Idle jet (60)	Gicleur minimum (60)	Leerlaufdüse (60)	Chiclé mínimo (60)	
F	26	8000 12029	1	Vite (aperta di 2 giri)	Screw (opening: turns 2)	Vis (ouverte de 2 tours)	Schraube (gelockert um Drehungen 2)	Tornillo (abierto de 2rev.)	

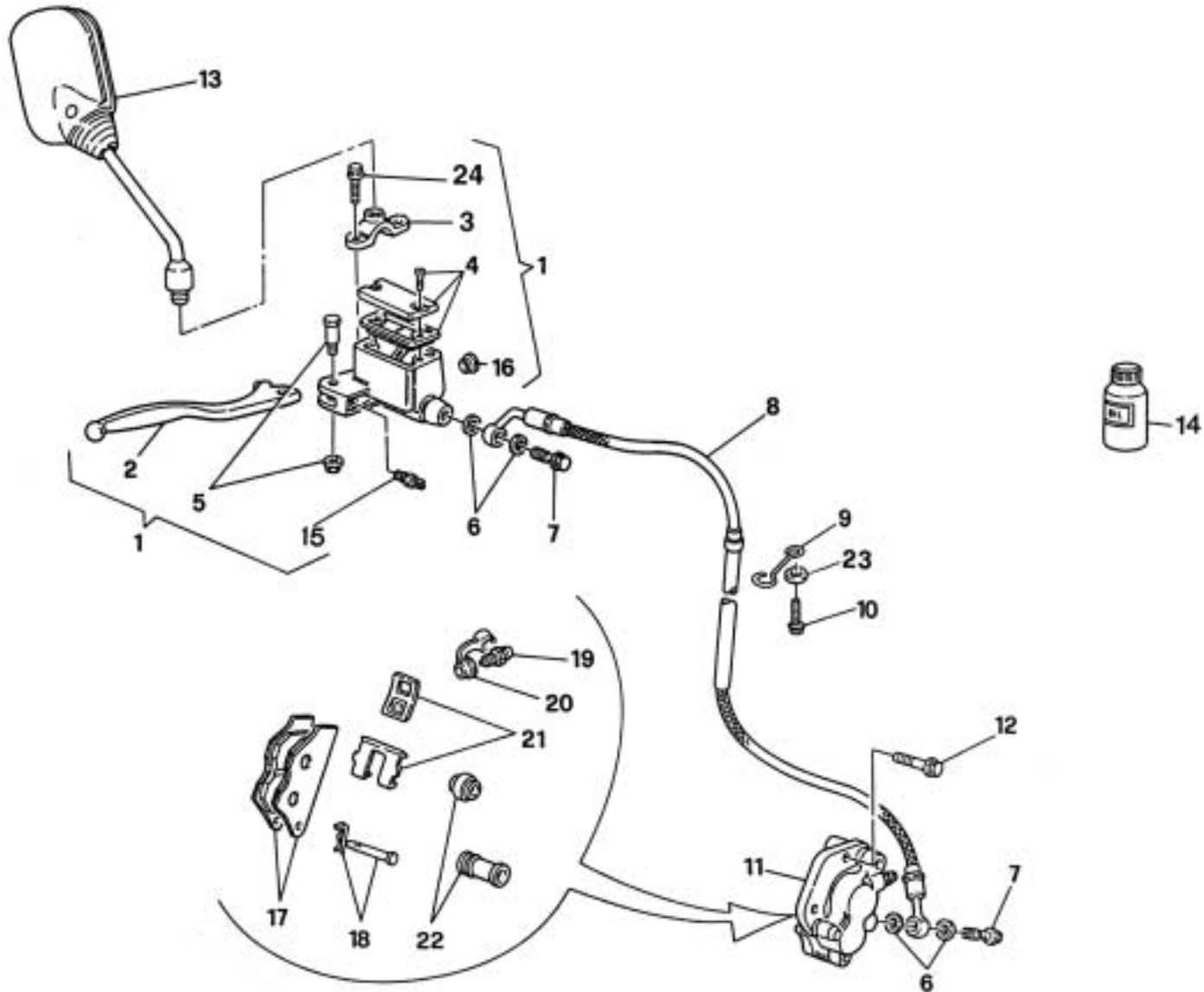

Note Notes Notes Marke Notas	Pos. No. N. Index Pos.	N. Cod. Code No. Nr. Code Code Nr N. Cod.	Q.tà Q.ty Q.te M.ge C.ad	DENOMINAZIONE	NAME	DESIGNATION	BESHREIBUNG	DENOMINACION	Validità Validity Validité Gültig Validez
	1	8A00 76024	1	Pompa comando freno ant.	Brake pump	Pompe frein	Bremspumpe	Bomba freno	
	2	8A00 79067	1	Leva	Lever	Levier	Hebel	Palanca	
	3	8000 79068	1	Cavallotto	U-bolt	Cavalier	Bügelbolzen	Caballete	
	4	8000 79069	1	Kit tappo	Plug kit	Bouchon kit	Verschluss Gruppe	Kit tapón	
	5	8000 79070	1	Perno	Pin	Pivot	Bolzen	Perno	
	6	8000 21480	4	Rosetta	Washer	Rondelle	Scheibe	Arandela	
	7	8000 57155	2	Vite	Screw	Vis	Schraube	Tornillo	
	8	8A00 76025	1	Tubo mandata olio	Pipe	Tuyau	Rohr	Tubo	
	9	8000 57167	1	Guida cavo	Cable guide	Guide câble	Kabelführung	Guía-cable	
	10	8A00 67997	1	Vite	Screw	Vis	Schraube	Tornillo	
	11	8A00 85998	1	Pinza freno	Brake caliper	Etrier frein	Bremssattel	Pinza	
	12	8000 62733	2	Vite	Screw	Vis	Schraube	Tornillo	
D	13	8000 58378	1	Specchio retrovisore compl.	Driving mirror	Rétroviseur	Ruckspiegel	Espejo retrovisor	
R	14	8000 71445	1	Olio freni	Brake oil	Huile frein	Bremsöl	Aceite freni	
	15	8000 95248	1	Interruttore stop	Stop switch	Interrupteur stop	Stopschalter	Interruptor stop	
	16	8000 49654	1	Oblò	Inspection plug	Capuchon de inspection	Stopfen	Portilla	
	17	8000 74181	1	Coppia pastiglie	Pads pair	Paire plaquettes	Bremsbelagpaar	Pareja pastillas	
	18	8000 85999	1	Perno	Pin	Pivot	Bolzen	Perno	
	19	8000 60404	1	Spurgo	Spurgo	Drain	Entleerung	Purga	
	20	8000 53259	1	Parapolvere	Boots	Para-poudre	Schutzhaube	Para-polvo	
	21	8000 79065	1	Molla-lamierino	Spring-steel clip	Ressort	Feder	Rresorte	
	22	8000 79066	1	Cuffie	Boots	Poussiers	haube	Gorro	
	23	8000 12634	1	Rosetta	Washer	Rondelle	Scheibe	Arandela	
	24	8000 62729	2	Vite	Screw	Vis	Schraube	Tornillo	

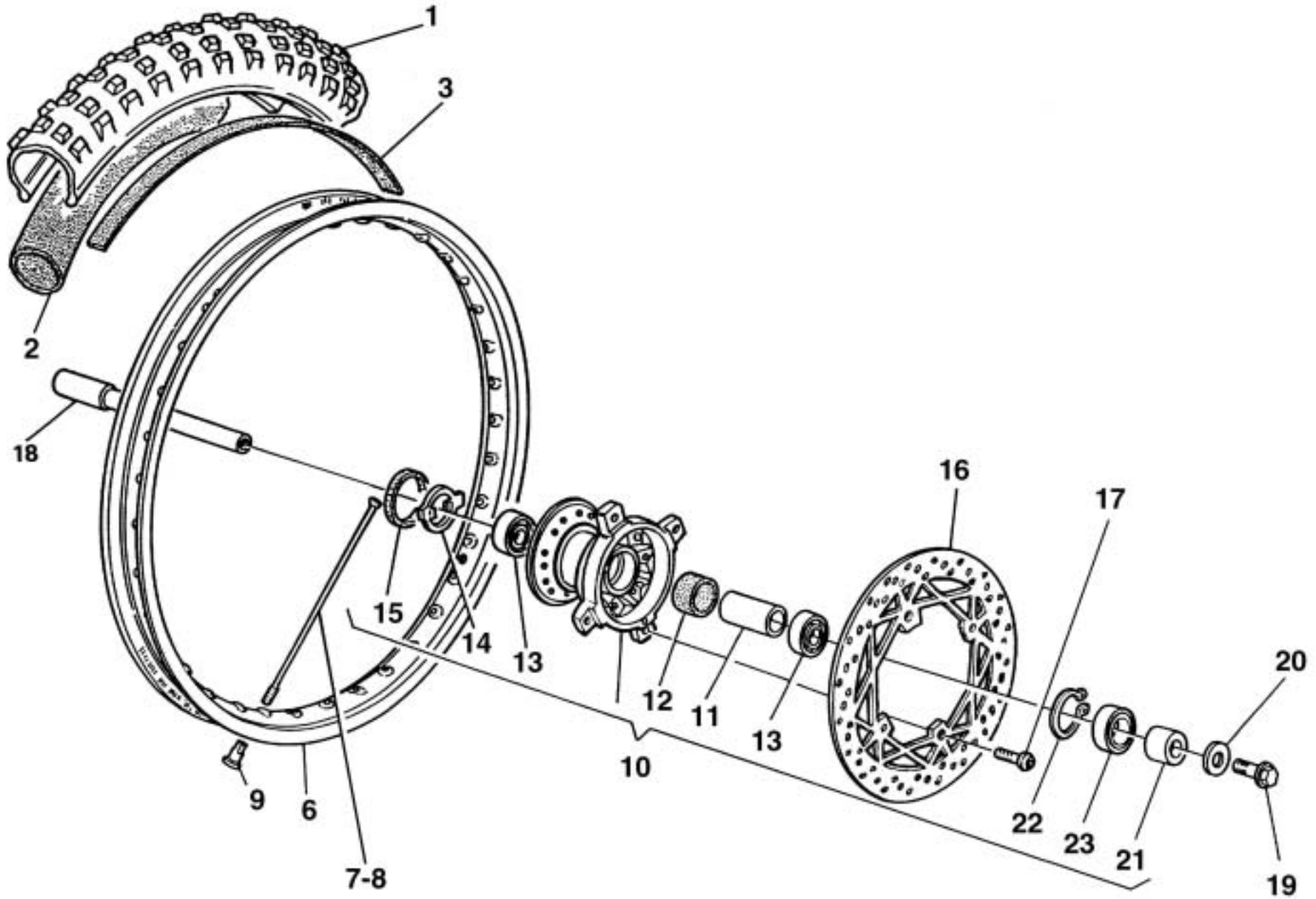



wre 125 dual purpose
sm 125 s / 2004

TAVOLA
DRAWING
TABLE
BILD
TABLA

22A

RUOTA ANTERIORE - FRONT WHEEL
ROUE AVANT - VORTERRAD
RUEDA DELANTERA

Note Notes Marke Notas	Pos. No. N. Index Pos.	N. Cod. Code No. Nr. Code Code Nr N. Cod.	Q.tà Q.ty Q.te M.ge C.ad	DENOMINAZIONE	NAME	DESIGNATION	BESHREIBUNG	DENOMINACION	Validità Validity Validité Gültig Validez
NW	1	8000 69486	1	Pneumatico (90/90 - 21") Pirelli MT 21	Tyre (90/90 - 21") Pirelli MT 21	Pneu (90/90 - 21") Pirelli MT 21	Reifen (90/90 - 21") Pirelli MT 21	Neumático (90/90 - 21") Pirelli MT 21	
NS	1	8000 97527	1	Pneumatico (120/70 - 17") Pirelli MT R21 DRAGON EVO	Tyre (120/70 - 17") Pirelli MT R21 DRAGON EVO	Pneu (120/70 - 17") Pirelli MT R21 DRAGON EVO	Reifen (120/70 - 17") Pirelli MT R21 DRAGON EVO	Neumático (120/70 - 17") Pirelli MT R21 DRAGON EVO	
ANS	1	8000 A3000	1	Pneumatico (120/70 - 17") Dunlop	Tyre (120/70 - 17") Dunlop	Pneu (120/70 - 17") Dunlop	Reifen (120/70 - 17") Dunlop	Neumático (120/70 - 17") Dunlop	
NW	2	8000 18648	1	Camera d'aria 21" (Pirelli)	Air tube 21" (Pirelli)	Chambre à air 21" (Pirelli)	Luftschlauch 21" (Pirelli)	Cámara de aire 21" (Pirelli)	
NS	2	8000 88739	1	Camera d'aria 17" (Pirelli)	Air tube 17" (Pirelli)	Chambre à air 17" (Pirelli)	Luftschlauch 17" (Pirelli)	Cámara de aire 17" (Pirelli)	
ANS	2	8000 A3003	1	Camera d'aria 17" (Dunlop)	Air tube 17" (Dunlop)	Chambre à air 17" (Dunlop)	Luftschlauch 17" (Dunlop)	Cámara de aire 17" (Dunlop)	
W	3	8000 13346	1	Fascia copriraggi	Rim strip	Bande	Band	Banda	
S	3	8B00 82879	1	Fascia copriraggi	Rim strip	Bande	Band	Banda	
W	6	8000 91524	1	Cerchio (1,6 x 21")	Rim (1,6 x 21")	Jante (1,6 x 21")	Felge (1,6 x 21")	Llanta (1,6 x 21")	
S	6	8000 94709	1	Cerchio (3,5 x 17")	Rim (3,5 x 17")	Jante (3,5 x 17")	Felge (3,5 x 17")	Llanta (3,5 x 17")	
W	7	8000 92693	18	Raggio destro	Spoke R.	Bras D.	Speiche R.	Radio der.	
S	7	8000 94754	18	Raggio destro	Spoke R.	Bras D.	Speiche R.	Radio der.	
W	8	8000 92693	18	Raggio sinistro	Spoke L.	Bras G.	Speiche L.	Radio izq.	
S	8	8000 94754	18	Raggio sinistro	Spoke L.	Bras G.	Speiche L.	Radio izq.	
	9	69N4 29004	36	Nipplo	Nipple	Nipple	Nippel	Nipple	
W	10	8000 96482	1	Mozzo completo	Hub assy	Moyeau compl.	Radnabe, Kpl.	Cubo compl.	
S	10	8000 94696	1	Mozzo completo	Hub assy	Moyeau compl.	Radnabe, Kpl.	Cubo compl.	
	11	8000 95629	1	Distanziale	Spacer	Entretoise	Distanzstück	Separador	
	12	8000 92797	1	Portadistanziale	Spacer holder	Porte-entretoise	Abstandstückhalter	Porta-distancial	
	13	8A00 39651	2	Cuscinetto a sfere (ø20xø42x12 mm)	Ball bearing (ø20xø42x12 mm)	Roulement à billes (ø20xø42x12 mm)	Kugellager (ø20xø42x12 mm)	Cojinete de bolas (ø20xø42x12 mm)	
A	13	8000 39651	2	Cuscinetto a sfere (ø20xø42x12 mm)	Ball bearing (ø20xø42x12 mm)	Roulement à billes (ø20xø42x12 mm)	Kugellager (ø20xø42x12 mm)	Cojinete de bolas (ø20xø42x12 mm)	
	14	8000 77884	1	Anello trascinatoro	Ring	Bague	Ring	Anillo	
	15	8000 51957	1	Anello di tenuta (ø40xø50x4 mm)	Seal ring (ø40xø50x4 mm)	Bague d'étanchéité (ø40xø50x4 mm)	Dichtungsring (ø40xø50x4 mm)	Anillo de retención (ø40xø50x4 mm)	
E	16	8A00 88884	1	Disco freno (Ø260 mm- 3,0mm)	Brake disc (Ø260 mm- 3,0mm)	Disque frein (Ø260 mm- 3,0mm)	Bremsscheibe (Ø260 mm- 3,0mm)	Disco freno (Ø260 mm- 3,0mm)	
	16	8B00 88884	1	Disco freno (Ø260 mm- 3,5mm)	Brake disc (Ø260 mm- 3,5mm)	Disque frein (Ø260 mm- 3,5mm)	Bremsscheibe (Ø260 mm- 3,5mm)	Disco freno (Ø260 mm- 3,5mm)	

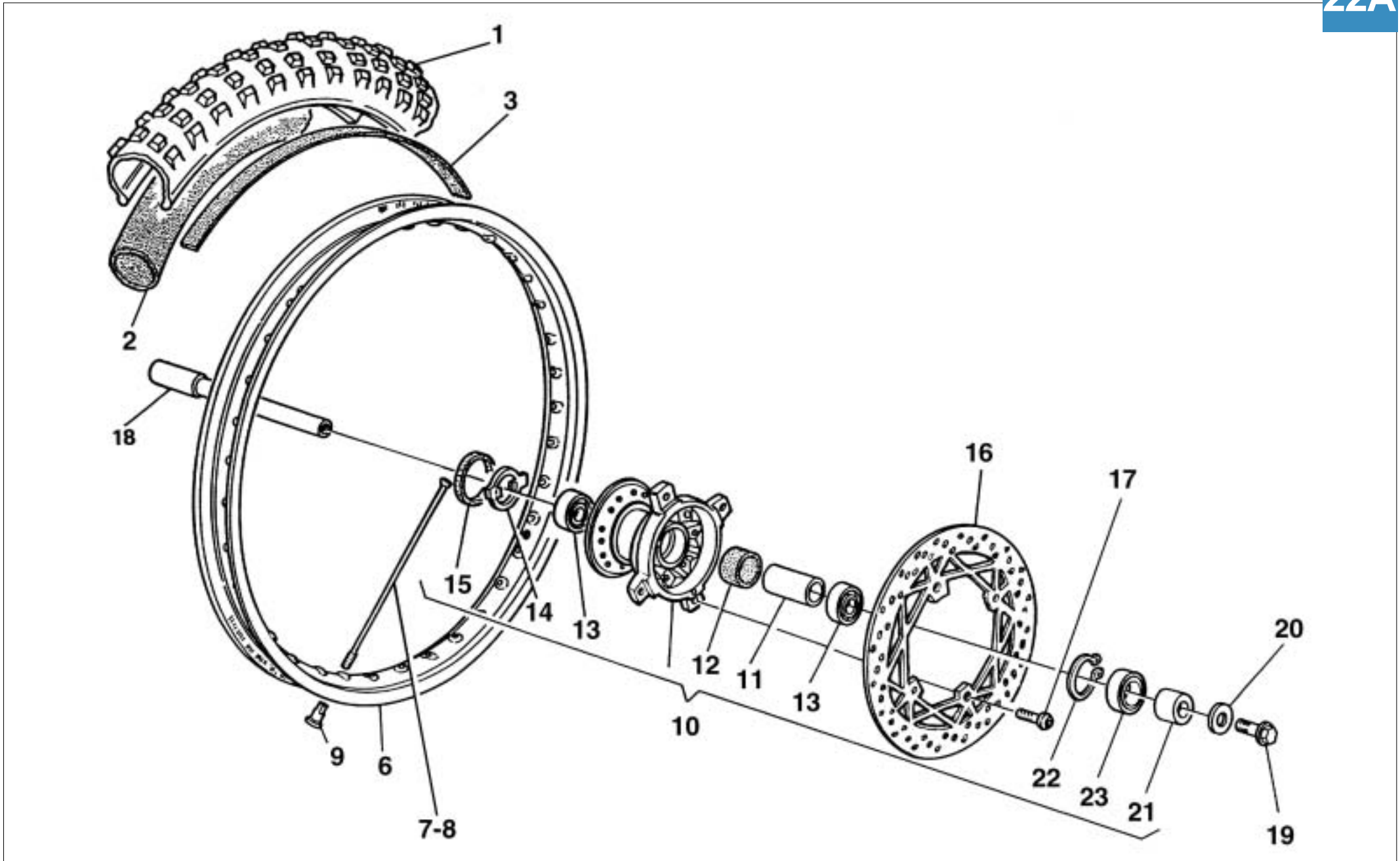

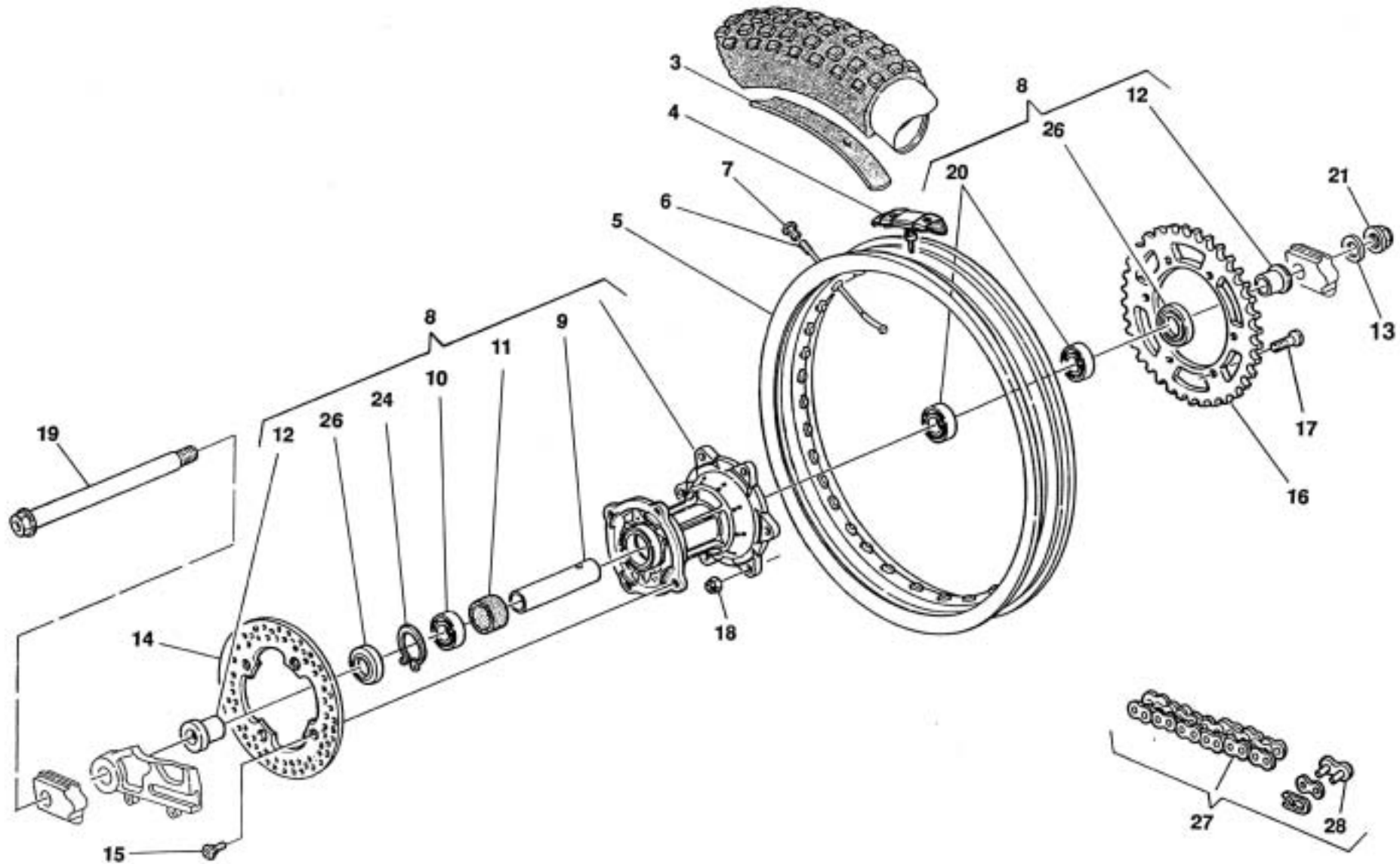

Note Notes Notes Marke Notas	Pos. No. N. Index Pos.	N. Cod. Code No. Nr. Code Code Nr N. Cod.	Q.tà Q.ty Q.te M.ge C.ad	DENOMINAZIONE	NAME	DESIGNATION	BESHREIBUNG	DENOMINACION	Validità Validity Validité Gültig Validez
NW	1	8D00 61085	1	Pneumatico (120/90 - 18") Pirelli MT 22	Tyre (120/90 - 18") Pirelli MT 22	Pneu (120/90 - 18") Pirelli MT 22	Reifen (120/90 - 18") Pirelli MT 22	Neumático (120/90 - 18") Pirelli MT 22	
NS	1	8000 88680	1	Pneumatico (150/60 - 17") Pirelli MT R22 DRAGON EVO	Tyre (150/60 - 17") Pirelli MT R22 DRAGON EVO	Pneu (150/60 - 17") Pirelli MT R22 DRAGON EVO	Reifen (150/60 - 17") Pirelli MT R22 DRAGON EVO	Neumático (150/60 - 17") Pirelli MT R22 DRAGON EVO	
ANS	1	8000 A3001	1	Pneumatico (150/60 - 17") Dunlop	Tyre (150/60 - 17") Dunlop	Pneu (150/60 - 17") Dunlop	Reifen (150/60 - 17") Dunlop	Neumático (150/60 - 17") Dunlop	
NW	2	8000 05080	1	Camera d'aria 18" Pirelli	Air tube 18" Pirelli	Chambre à air 18" Pirelli	Luftschlauch 18" Pirelli	Cámara de aire 18" Pirelli	
NS	2	8000 51862	1	Camera d'aria 17" Pirelli	Air tube 17" Pirelli	Chambre à air 17" Pirelli	Luftschlauch 17" Pirelli	Cámara de aire 17" Pirelli	
ANS	2	8000 A3002	1	Camera d'aria 17" Dunlop	Air tube 17" Dunlop	Chambre à air 17" Dunlop	Luftschlauch 17" Dunlop	Cámara de aire 17" Dunlop	
W	3	8000 01688	1	Fascia copriraggi	Rim strip	Bande	Band	Banda	
S	3	8B00 82879	1	Fascia copriraggi	Rim strip	Bande	Band	Banda	
W	5	8000 91527	1	Cerchio (2,15 x 18")	Rim (2,15 x 18")	Jante (2,15 x 18")	Felge (2,15 x 18")	Llanta (2,15 x 18")	
S	5	8000 94713	1	Cerchio (4,25 x 17")	Rim (4,25 x 17")	Jante (4,25 x 17")	Felge (4,25 x 17")	Llanta (4,25 x 17")	
W	6	8000 92703	36	Raggio	Spoke	Bras	Speiche	Radio	
S	6	8000 94757	18	Raggio (l=174 mm)	Spoke (l=174 mm)	Bras (l=174 mm)	Speiche (l=174 mm)	Radio (l=174 mm)	
S	6	8000 95341	18	Raggio (l=178 mm)	Spoke (l=178 mm)	Bras (l=178 mm)	Speiche (l=178 mm)	Radio (l=178 mm)	
	7	69N4 29005	36	Nipplo	Nipple	Nipple	Nippel	Nipple	
	8	8000 94700	1	Mozzo completo	Hub assy	Moyeau compl.	Radnabe, Kpl.	Cubo compl.	
	9	8A00 86938	1	Distanziale	Spacer	Entretoise	Distanzstück	Separador	
	10	8B00 26846	1	Cuscinetto (ø25xø47x16 mm)	Bearing (ø25xø47x16 mm)	Roulement (ø25xø47x16 mm)	Kugellager (ø25xø47x16 mm)	Cojinete (ø25xø47x16 mm)	
A	10	8D00 26846	1	Cuscinetto (ø25xø47x16 mm)	Bearing (ø25xø47x16 mm)	Roulement (ø25xø47x16 mm)	Kugellager (ø25xø47x16 mm)	Cojinete (ø25xø47x16 mm)	
	11	8000 92797	1	Porta distanziale	Spacer	Entretoise	Distanzstück	Separador	
	12	8A00 92413	1	Distanziale	Spacer	Entretoise	Distanzstück	Separador	
	13	80A0 19963	1	Rosetta	Washer	Rondelle	Scheibe	Arandela	
	14	8000 88887	1	Disco freno (ø220 mm)	Brake disc (ø220 mm)	Disque frein (ø220 mm)	Bremsscheibe (ø220 mm)	Disco freno (ø220 mm)	
	15	8000 55878	4	Vite	Screw	Vis	Schraube	Tornillo	
	16	8D00 75703	1	Corona (Z = 49)	Ring gear (Z = 49)	Couronne (Z = 49)	Kranz (Z = 49)	Corona (Z = 49)	
	17	8C00 40796	6	Vite	Screw	Vis	Schraube	Tornillo	
	18	8000 43928	6	Dado	Nut	Ecrou	Mutter	Tuierca	
	19	8E00 64938	1	Perno	Pin	Pivot	Bolzen	Perno	
A	19	8D00 64938	1	Perno	Pin	Pivot	Bolzen	Perno	
	20	8A00 26846	2	Cuscinetto (ø25xø47x12 mm)	Bearing (ø25xø47x12 mm)	Roulement (ø25xø47x12 mm)	Kugellager (ø25xø47x12 mm)	Cojinete (ø25xø47x12 mm)	
A	20	8C00 26846	2	Cuscinetto (ø25xø47x12 mm)	Bearing (ø25xø47x12 mm)	Roulement (ø25xø47x12 mm)	Kugellager (ø25xø47x12 mm)	Cojinete (ø25xø47x12 mm)	

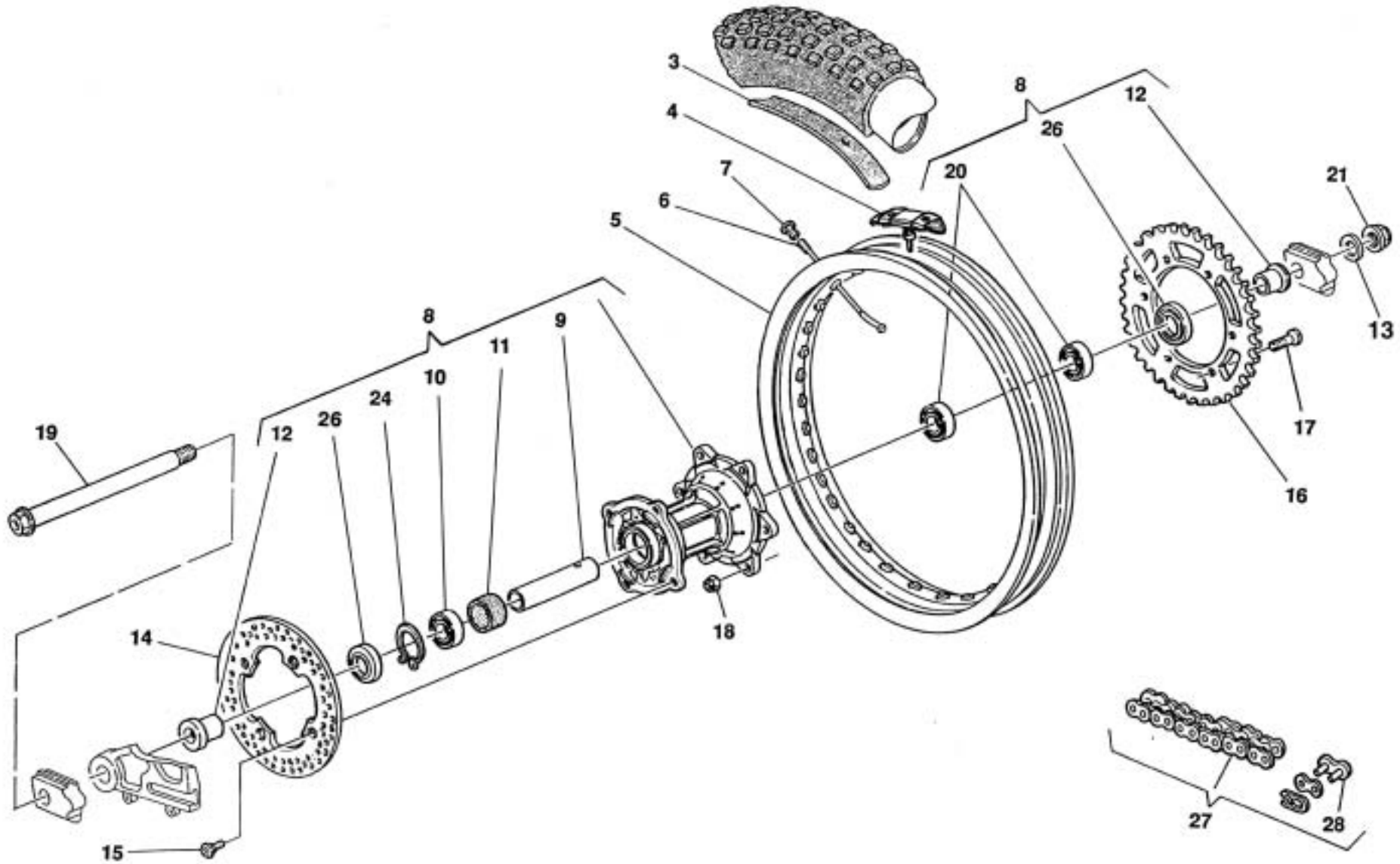



wre 125 dual purpose
sm 125 s / 2004

TAVOLA
DRAWING
TABLE
BILD
TABLA

23

RUOTA POSTERIORE - REAR WHEEL - ROUE ARRIERE - HINTERRAD
RUEDA TRASERA

Note Notes Notes Marke Notas	Pos. No. N. Index Pos.	N. Cod. Code No. Nr. Code Code Nr N. Cod.	Q.tà Q.ty Q.te M.ge C.ad	DENOMINAZIONE	NAME	DESIGNATION	BESHREIBUNG	DENOMINACION	Validità Validity Validité Gültig Validez
	21	8000 62613	1	Dado	Nut	Ecrou	Mutter	Tuerca	
	24	66N0 21272	1	Anello elastico	Split ring	Anneau ressort	Sprengring	Anillo elástico	
	26	8000 89572	2	Anello di tenuta (ø32xø47x7 mm)	Seal ring (ø32xø47x7 mm)	Bague d'étanchéité (ø32xø47x7 mm)	Dichtungsring (ø32xø47x7 mm)	Anillo de retención (ø32xø47x7 mm)	
W	27	8A00 56768	1	Catena 5/8"x1/4"(112maglie)	Chain 5/8"x1/4"(112 links)	Chaîne 5/8"x1/4"(112maillon)	Kette 5/8"x1/4"(112Schake)	Cadena 5/8"x1/4"(112malla)	
WA	27	8G00 79785	1	Catena 5/8"x1/4"(112maglie)	Chain 5/8"x1/4"(112 links)	Chaîne 5/8"x1/4"(112maillon)	Kette 5/8"x1/4"(112Schake)	Cadena 5/8"x1/4"(112malla)	
S	27	8000 56768	1	Catena 5/8"x1/4"(114maglie)	Chain 5/8"x1/4"(114 links)	Chaîne 5/8"x1/4"(114maillon)	Kette 5/8"x1/4"(114Schake)	Cadena 5/8"x1/4"(114malla)	
SA	27	8B00 79785	1	Catena 5/8"x1/4"(114maglie)	Chain 5/8"x1/4"(114 links)	Chaîne 5/8"x1/4"(114maillon)	Kette 5/8"x1/4"(114Schake)	Cadena 5/8"x1/4"(114malla)	
	28	8000 56767	1	Giunto	Coupling	Joint	Kupplung	Junta	
A	28	8000 79790	1	Giunto	Coupling	Joint	Kupplung	Junta	

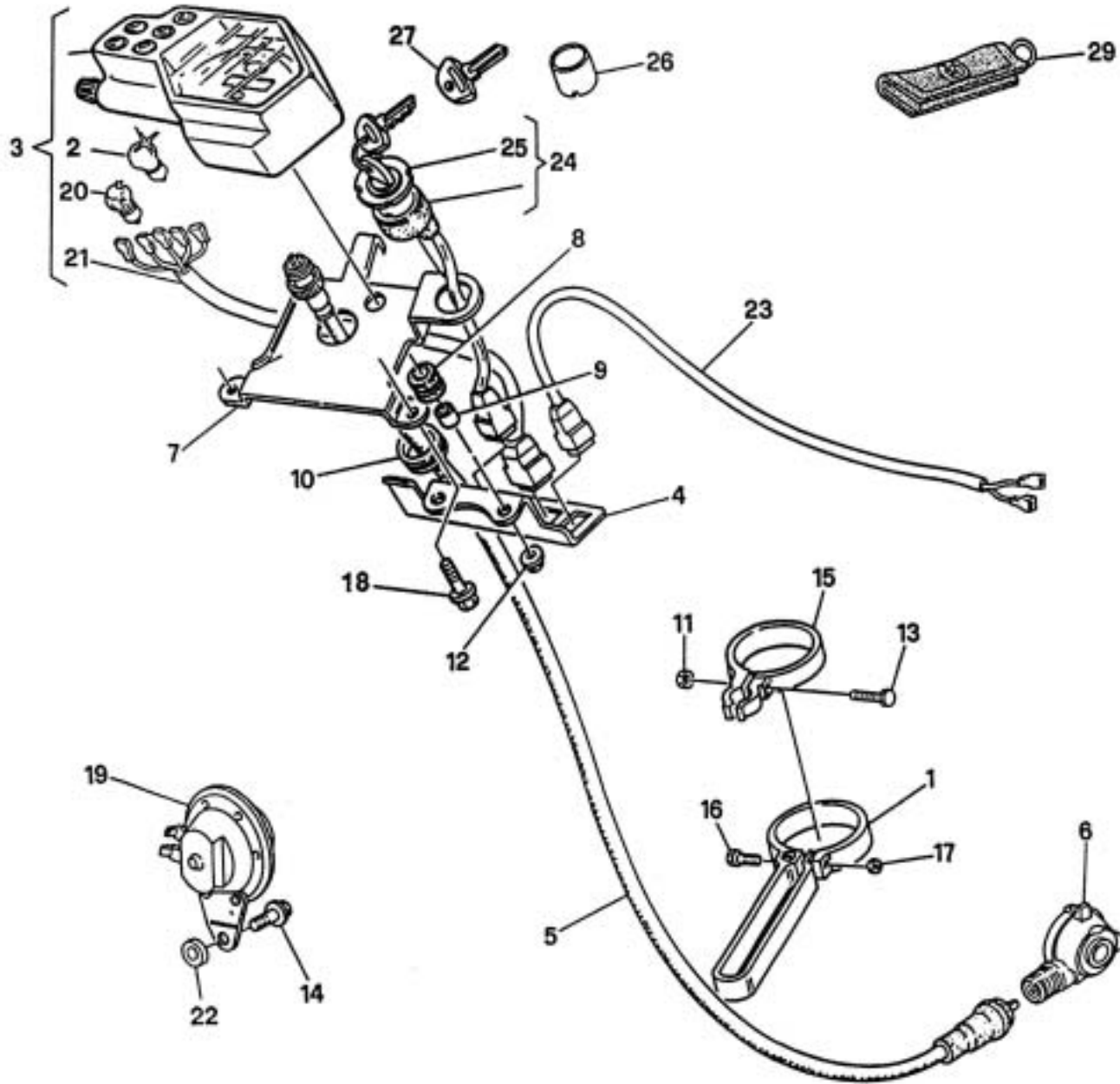

Note Notes Marke Notas	Pos. No. N. Index Pos.	N. Cod. Code No. Nr. Code Code Nr N. Cod.	Q.tà Q.ty Q.te M.ge C.ad	DENOMINAZIONE	NAME	DESIGNATION	BESHREIBUNG	DENOMINACION	Validità Validity Validité Gültig Validez
	1	8AA0 65340	1	Guidatrasmissioni	Cable	Cable	Kabel	Cable	
	2	8000 60033	4	Lampadina (12V - 2W)	Lamp (12V - 2W)	Lampe (12V - 2W)	Lampe (12V - 2W)	Lamparilla (12V - 2W)	
E	3	8000 88545	1	Ass. contachilometri	Speedometer assy	Compteur-km. compl.	Tachometer kpl.	Cuenta-kilómetros compl.	
	3	8000 91971	1	Ass. contachilometri	Speedometer assy	Compteur-km. compl.	Tachometer kpl.	Cuenta-kilómetros compl.	
	4	8000 69428	1	Piastra	Plate	Plaque	Platte	Placa	
	5	8000 71759	1	Trasmissione contachilometri	Speedometer cable	Câble compteur - km	Tachokabel	Cable cuenta-kilómetros	
W	6	8000 77827	1	Rinvio contachilometri	Odometer transm.	Renvoi compte-km.	Vorgelege Kilometerzähler	Reenvío cuenta-kilómetros	
S	6	8000 88386	1	Rinvio contachilometri	Odometer transm.	Renvoi compte-km.	Vorgelege Kilometerzähler	Reenvío cuenta-kilómetros	
	7	8000 88648	1	Piastra	Plate	Plaque	Platte	Placa	
	8	8000 62651	2	Antivibrante	Silent-block	Antivibration	Schwingungsdämpfer	Anti-vibrador	
	9	8000 25053	2	Distanziale	Spacer	Entretoise	Distanzstück	Separador	
	10	8000 72648	2	Gommino	Rubber pad	Piece caoutchouc	Gummistück	Junta de goma	
	11	8000 40718	1	Dado	Nut	Ecrou	Mutter	Tuerca	
	12	8000 61313	2	Dado	Nut	Ecrou	Mutter	Tuerca	
	13	8B00 66525	1	Vite	Screw	Vis	Schraube	Tornillo	
	14	8000 62726	1	Vite	Screw	Vis	Schraube	Tornillo	
	15	8AA0 70581	1	Fascetta	Clamp	Collier	Schelle	Banda	
	16	8B00 66525	1	Vite	Screw	Vis	Schraube	Tornillo	
	17	61N1 15192	1	Dado	Nut	Ecrou	Mutter	Tuerca	
	18	8000 67997	1	Vite	Screw	Vis	Schraubez	Tornillo	
	19	8000 75836	1	Avvisatore acustico	Horn	Signal acoustique	Hupe	Avisador acústico	
	20	8000 20602	3	Lampadina (12V - 1,2W)	Lamp (12V - 1,2W)	Lampe (12V - 1,2W)	Lampe (12V - 1,2W)	Lamparilla (12V - 1,2W)	
	21	8000 88543	1	Cavi	Cable	Cable	Kabel	Cable	
	22	8000 60969	1	Rosetta	Washer	Rondelle	Scheibe	Arandela	
	23	8000 75477	1	Cavi	Cable	Cable	Kabel	Cable	
	24	8000 74259	1	Interr. accensione completo	Ignition switch assy	Interrupteur pour allum. comp.	Schalter, Kpl.	Interruptor encendido compl.	
	25	8000 74258	1	Ghiera	Ring nut	Embout	Nutmutter	Virola	
	26	8000 50569	1	Distanziale	Spacer	Entretoise	Distanzstück	Separador	
	27	8000 38210	1	Chiave grezza	Raw key	Cléf primitive	Schlüssel	Llave	
	29	8000 97615	1	Portachiavi	Key-ring	Porte-cléfs	Schlüsselring	Llavero	

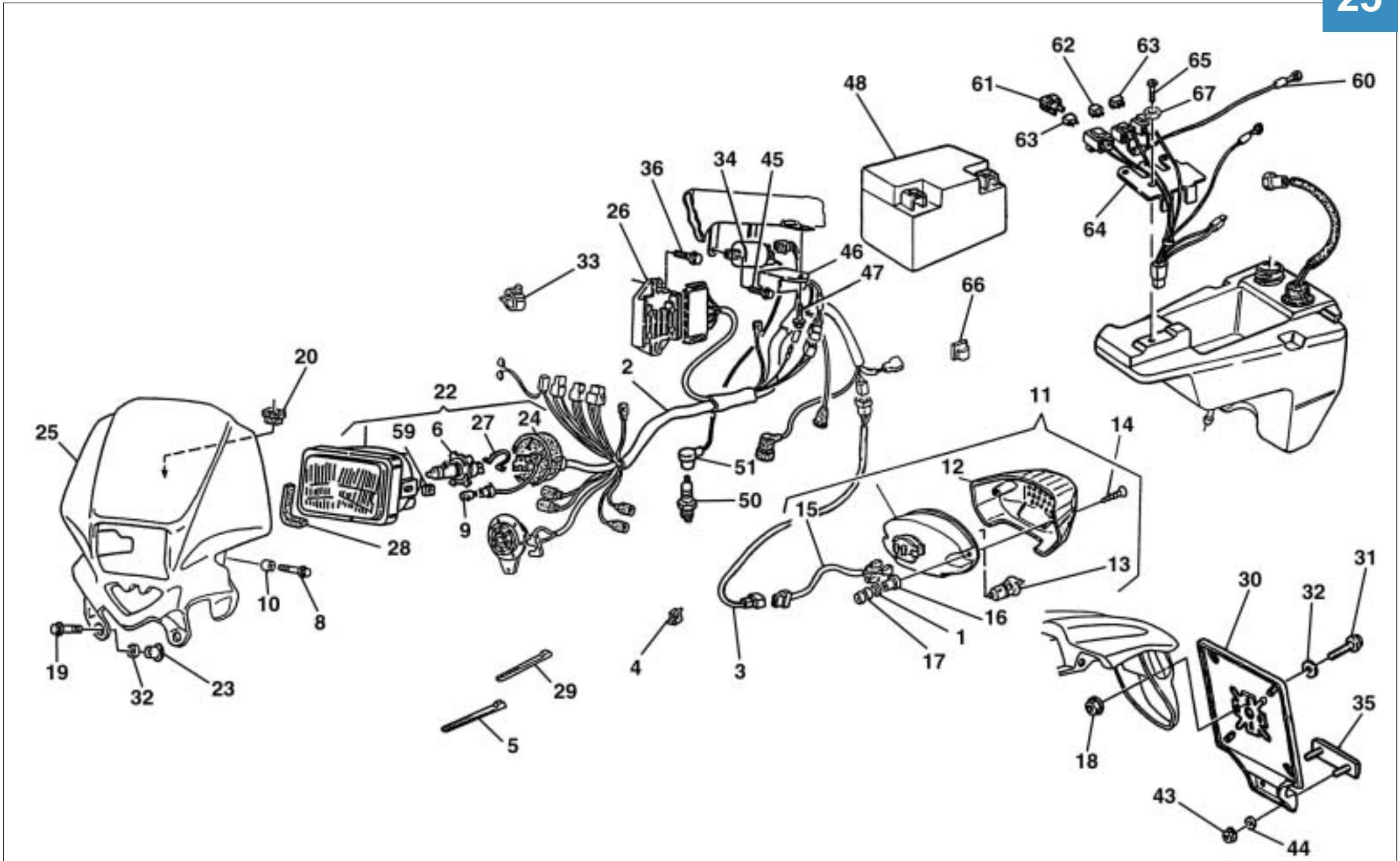

Note Notes Marke Notas	Pos. No. N. Index Pos.	N. Cod. Code No. Nr. Code Code Nr N. Cod.	Q.tà Q.ty Q.te M.ge C.ad	DENOMINAZIONE	NAME	DESIGNATION	BESHREIBUNG	DENOMINACION	Validità Validity Validité Gültig Validez
	1	62N1 15549	2	Rosetta piana	Washer	Rondelle	Scheibe	Arandela	
	2	8000 95419	1	Gruppo principale cavi	Cable assy	Cables compl.	Kabel Kpl.	Grupo principal cables	
	3	8000 70277	1	Cavo posteriore	Cable	Cable	Kabel	Cable	
	4	8000 72494	1	Passacavo	Fairlead	Passe-câble	Kabelführung	Prensa-cable	
	5	8000 71578	4	Fascetta	Clamp	Collier	Schelle	Banda	
	6	8000 42946	1	Lampada (12V-55/60W)	Lamp (12V-55/60W)	Lampe (12V-55/60W)	Lampe (12V-55/60W)	Lamparilla (12V-55/60W)	
	8	8000 62728	2	Vite	Screw	Vis	Schraube	Tornillo	
	9	8000 36727	1	Lampada (12V-3W)	Lamp (12V-3W)	Lampe (12V-3W)	Lampe (12V-3W)	Lamparilla (12V-3W)	
	10	8B00 69429	2	Bussola	Bush	Douille	Buchse	Manguito	
	11	8A00 88873	1	Fanale posteriore completo	Tail light	Feux derniere	Hinterleuchte	Faro trasero	
	12	8A00 94119	1	Lente	Lens	Loupe	Linse	Lente	
	13	8A00 18246	1	Lampada (12V-5/21W)	Lamp (12V-5/21W)	Lampe (12V-5/21W)	Lampe (12V-5/21W)	Lamparilla (12V-5/21W)	
	14	8000 A0953	2	Vite	Screw	Vis	Schraube	Tornillo	
	15	8000 94121	1	Cablaggio	Cable assy	Cables compl.	Kabel Kpl.	Grupo cables	
	16	8000 94120	2	Distanziale	Spacer	Entretoise	Distanzstück	Separador	
	17	8000 18048	2	Gommino	Rubber pad	Pièce caoutchouc	Gummistück	Junta de goma	
	18	8000 44240	2	Dado	Nut	Ecrou	Mutter	Tuerca	
	19	8000 62730	2	Vite	Screw	Vis	Schraube	Tornillo	
	20	8000 50808	1	Gommino	Rubber pad	Pièce caoutchouc	Gummistück	Junta de goma	
	22	8000 87562	1	Gruppo ottico completo	Optical group	Groupe optique	Optische Gruppe	Grupo óptico	
	22	8000 90197	1	Gr. ottico compl.(AUS, J, GB)	Optical group (AUS, J, GB)	Groupe optique (AUS, J, GB)	Optische Gruppe(AUS, J, GB)	Grupo óptico (AUS, J, GB)	
	23	8D00 70034	2	Distanziale	Spacer	Entretoise	Distanzstück	Separador	
	24	8000 95649	1	Cuffia in gomma	Boot	Poussière	Gummihaube	Gorro de protección en goma	
W	25	80F0 87060	1	Cupolino	Fairing	Carenage	Verkleidung	Cúpula	
S	25	80F0 87060	1	Cupolino (cod. col. E)	Fairing (col.code E)	Carenage (code col. E)	Verkleidung (Code Farbe E)	Cúpula (cod. col. E)	
S	25	80C0 87060	1	Cupolino (cod. col. G)	Fairing (col.code G)	Carenage (code col. G)	Verkleidung (Code Farbe G)	Cúpula (cod. col. G)	
	26	8000 42274	1	Regolatore	Regulator	Regulateur	Regler	Regulador	
	27	8000 95648	1	Molletta	Spring	Ressort	Feder	Resorte	
	28	8000 88139	1	Guarnizione	Gasket	Garniture	Dichtung	Junta	
	29	8000 56444	5	Fascetta	Clamp	Collier	Schelle	Banda	
	30	8000 94595	1	Portatarga	Licence plate holder	Portebalai	Schildträger	Portamatricula	
	31	8000 62727	2	Vite	Screw	Vis	Schraube	Tornillo	
	32	8000 56359	2	Rosetta	Washer	Rondelle	Scheibe	Arandela	

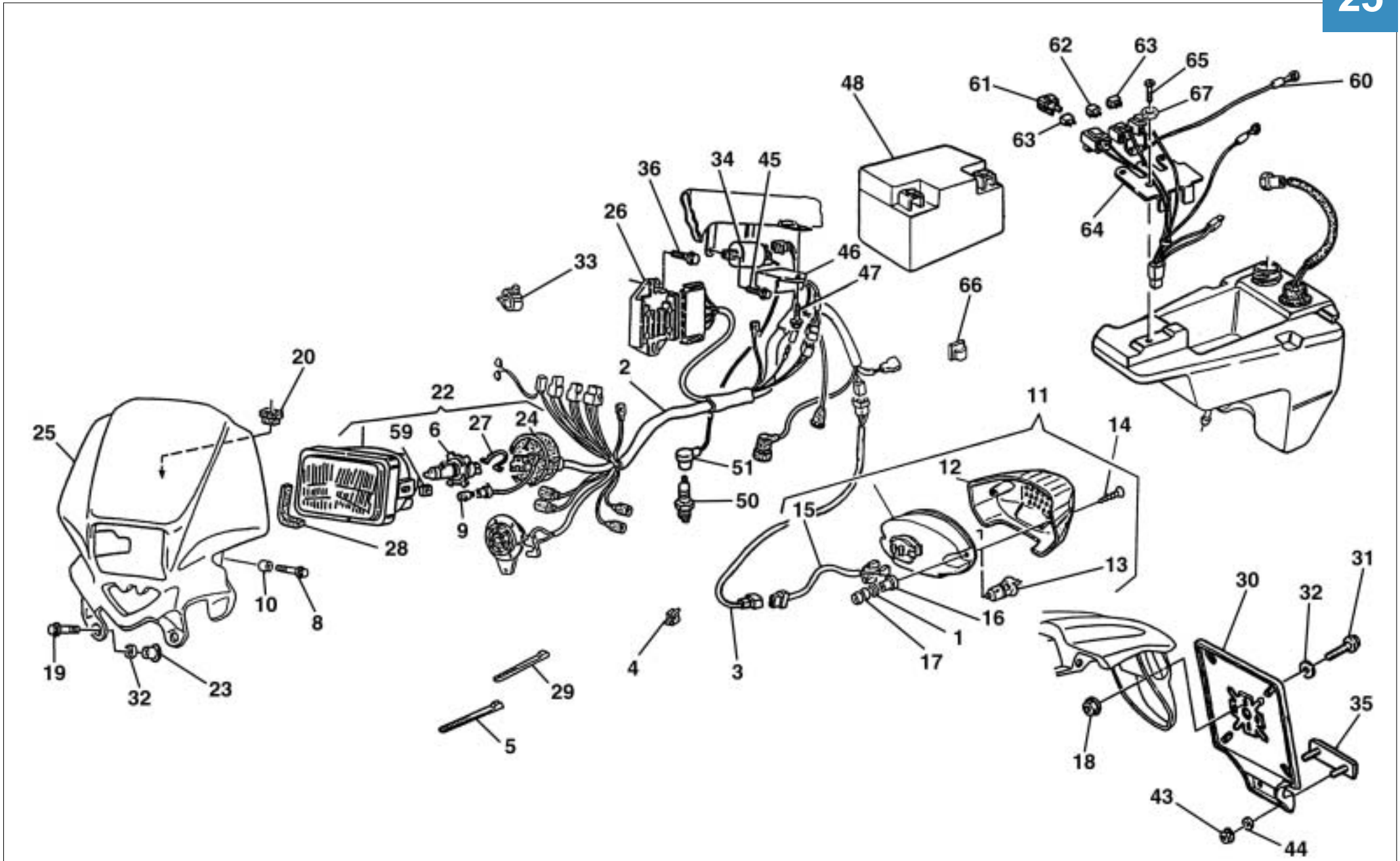



wre 125 dual purpose
sm 125 s / 2004

TAVOLA
DRAWING
TABLE
BILD
TABLA

25

IMPIANTO ELETTRICO, PORTATARGA, PORTANUMERO - ELECTRIC SYSTEM, PLATE HOLDER,
NUMBER HOLDER - INSTALLATION ELECT., PORTE-BALAI, PORTE-NOMBRE - ELEKTR. ANLAGE,
SCHILDTRAEGER, NUMMERTRAGER - INSTALAC. ELECTR., PORTA-MATRICULA, PORTA NUMERO

Note Notes Marke Notas	Pos. No. N. Index Pos.	N. Cod. Code No. Nr. Code Code Nr N. Cod.	Q.tà Q.ty Q.te M.ge C.ad	DENOMINAZIONE	NAME	DESIGNATION	BESHREIBUNG	DENOMINACION	Validità Validity Validité Gültig Validez
	33	8000 58207	1	Passacavo	Fairlead	Passe-câble	Kabelführung	Prensa-cable	
	34	8000 42272	1	Bobina	Coil	Bobine	Zundspule	Bobina	
	35	8000 73834	1	Catadiottro	Reflector	Catadioptrique	Ruckstrahler	Catafaros	
	36	8000 62727	2	Vite	Screw	Vis	Schraube	Tornillo	
	43	8000 40717	2	Dado	Nut	Ecrou	Mutter	Tuerca	
	44	62N1 15547	2	Rosetta	Washer	Rondelle	Scheibe	Arandela	
	45	8000 62728	2	Vite	Screw	Vis	Schraube	Tornillo	
	46	8000 59394	1	Centralina	Eletronic device	Dispositif eletronic	Zundelektronic	Centralita electronica	
	47	8000 62725	1	Vite	Screw	Vis	Schraube	Tornillo	
	48	8000 90719	1	Accumulatore (12V-4Ah)	Battery (12V-4Ah)	Batterie (12V-4Ah)	Batterie (12V-4Ah)	Bateria (12V-4Ah)	
	50	8A00 57446	1	Candela (NGK BR9)	Spark plug (NGK BR9)	Bougie (NGK BR9)	Zundkerze (NGK BR9)	Bujia (NGK BR9)	
A	50	8000 88759	1	Candela (Champion QN 84)	Spark plug (Champion QN 84)	Bougie (Champion QN 84)	Zundkerze (Champion QN 84)	Bujia (Champion QN 84)	
	51	8000 90877	1	Pipetta	Pipette	Pipette	Pipette	Pipa	
	59	8000 95650	1	Dado	Nut	Ecrou	Mutter	Tuerca	
	60	8000 95645	1	Cablaggio portafusibili	Fuses cable assy	Cables fusibles compl.	SicherungKabel Kpl.	Grupo cables fusibles	
	61	8000 95646	3	Coperchietto	Cover	Couvercle	Deckel	Tapa	
	62	8A00 95647	1	Fusibile (3A)	Fuse (3A)	Fusible (3A)	Sicherung (3A)	Fusible (3A)	
	63	8F00 95647	2	Fusibile (15A)	Fuse (15A)	Fusible (15A)	Sicherung (15A)	Fusible (15A)	
	64	8000 95644	1	Piastrina	Plate	Plaquette	Platte	Placa	
	65	8000 66774	1	Vite	Screw	Vis	Schraube	Tornillo	
	66	8000 57205	1	Passacavo	Fairlead	Passe-câble	Kabelführung	Prensa-cable	
	67	62N1 15534	1	Rosetta	Washer	Rondelle	Scheibe	Arandela	

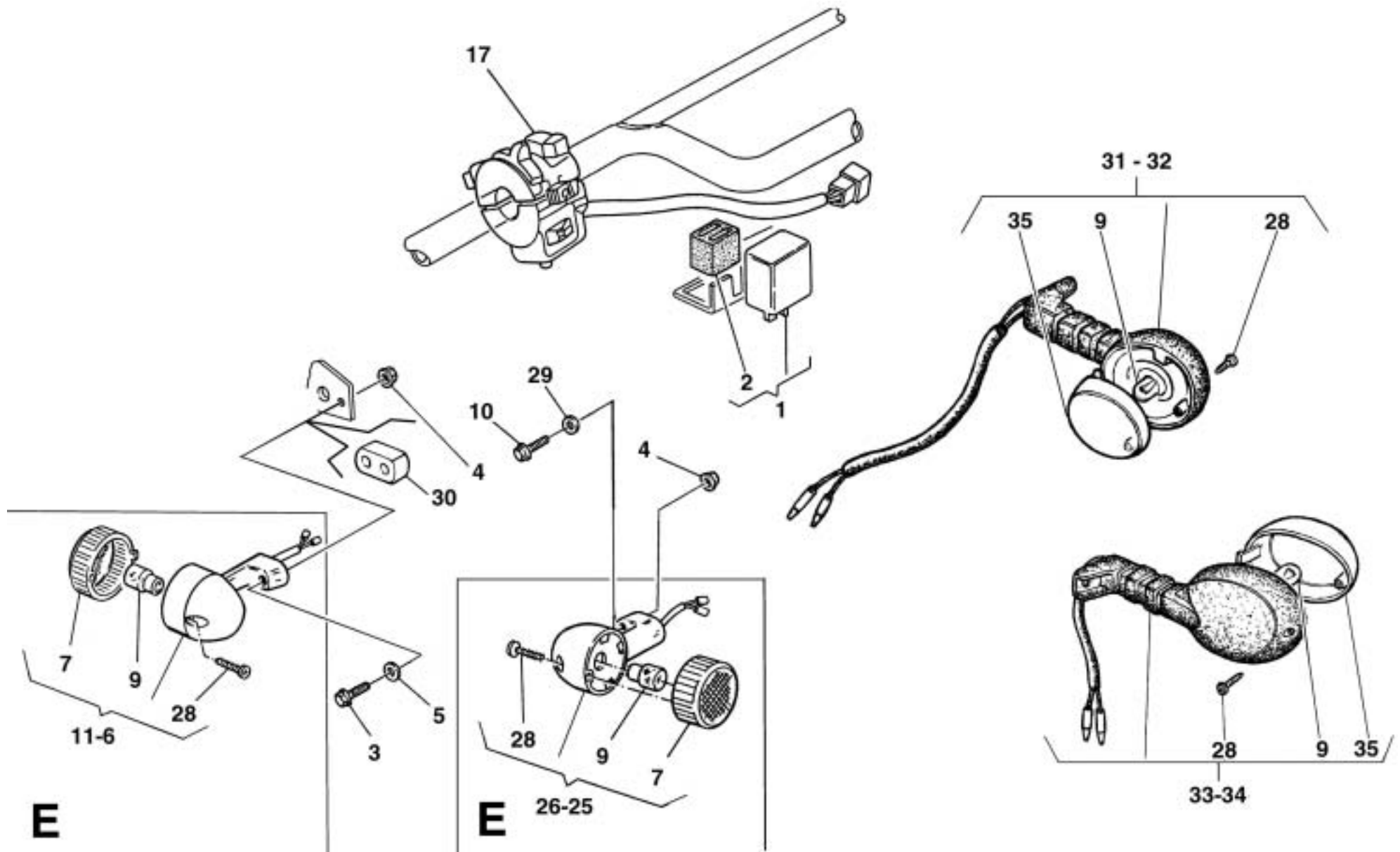



wre 125 dual purpose
sm 125 s / 2004

TAVOLA
DRAWING
TABLE
BILD
TABLA

26

FRECCE - BLINKER-
CLIGNOTANT - BLINKER-
INTERMITENTE

Note Notes Notes Marke Notas	Pos. No. N. Index Pos.	N. Cod. Code No. Nr. Code Code Nr N. Cod.	Q.tà Q.ty Q.te M.ge C.ad	DENOMINAZIONE	NAME	DESIGNATION	BESHREIBUNG	DENOMINACION	Validità Validity Validité Gültig Validez
	1	8000 88173	1	Intermittenza	Flash device	Intermittence	Blinkgeber	Intermitencia	
	2	8000 88259	1	Supporto elastico	Support	Support	Halterung	Soporte	
	3	8000 62728	2	Vite	Screw	Vis	Schraube	Tornillo	
	3	8B00 67545	2	Vite (AUS)	Screw (AUS)	Vis (AUS)	Schraube (AUS)	Tornillo (AUS)	
	4	8000 44240	4	Dado	Nut	Ecrou	Mutter	Tuerca	
	5	8000 45495	2	Bussola	Bush	Douille	Buchse	Manguito	
E	6	8000 88336	1	Indicatore anteriore dx.	R. blinker	Clignotant D. avant	Vordere Blinker R.	Intermitente D. delantero	
E	7	8000 73591	4	Lente	Lens	Loupe	Linse	Lente	
	9	8000 36726	4	Lampada (12V - 10W)	Lamp (12V - 10W)	Lampe (12V - 10W)	Lampe (12V - 10W)	Lamparilla (12V - 10W)	
	10	8000 62728	2	Vite	Screw	Vis	Schraube	Tornillo	
E	11	8000 88337	1	Indicatore anteriore sx.	L. blinker	Clignotant G. avant	Vordere Blinker L.	Intermitente I. delantero	
	17	8000 96563	1	Commutatore compl.	Switch compl.	Commutateur compl.	Kombischalter kpl.	Conmutador compl.	
	17	8000 95249	1	Commutatore compl. (J)	Switch compl. (J)	Commutateur compl. (J)	Kombischalter kpl. (J)	Conmutador compl. (J)	
E	25	8000 88334	1	Indicatore posteriore dx.	Rear R. blinker	Clignotant D. arriere	Hintere Blinker R.	Intermitente D. Trasero	
E	26	8000 88335	1	Indicatore posteriore sx.	Rear L. blinker	Clignotant G. arriere	Hintere Blinker L.	Intermitente I. Trasero	
	29	8000 56359	2	Rosetta	Washer	Rondelle	Scheibe	Roseta	
	30	8D00 69634	2	Distanziale (AUS)	Spacer (AUS)	Entretoise (AUS)	Distanzstück (AUS)	Separador (AUS)	
	31	8000 98241	1	Indicatore anteriore sx.	L. blinker	Clignotant G. avant	Vordere Blinker L.	Intermitente I. delantero	
	32	8000 98240	1	Indicatore anteriore dx.	R. blinker	Clignotant D. avant	Vordere Blinker R.	Intermitente D. delantero	
	33	8000 99585	1	Indicatore posteriore sx.	Rear L. blinker	Clignotant G. arriere	Hintere Blinker L.	Intermitente I. Trasero	
	34	8000 99584	1	Indicatore posteriore dx.	Rear R. blinker	Clignotant D. arriere	Hintere Blinker R.	Intermitente D. Trasero	
	35	8000 99583	4	Lente	Lens	Loupe	Linse	Lente	

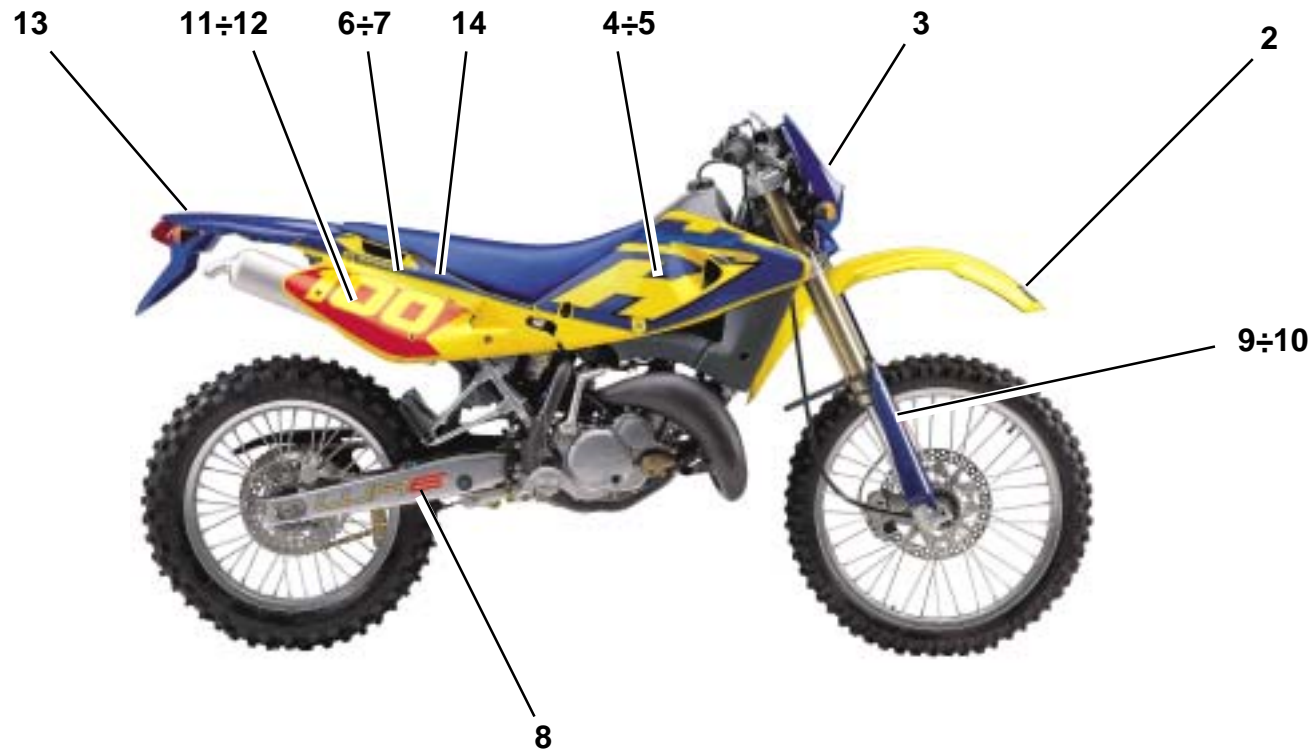

Note Notes Notes Marke Notas	Pos. No. N. Index Pos.	N. Cod. Code No. Nr. Code Code Nr N. Cod.	Q.tà Q.ty Q.te M.ge C.ad	DENOMINAZIONE	NAME	DESIGNATION	BESHREIBUNG	DENOMINACION	Validità Validity Validité Gültig Validez
	2	8000 A3196	1	Decal portafaro	Transfer	Décalcomanie	Abziehbild	Calcomania	
	3	8000 A3195	1	Decal per parafango anteriore	Transfer	Décalcomanie	Abziehbild	Calcomania	
	4	8A00 A2782	1	Decal per convogliatore Dx	R.H. transfer	Décalcomanie D.	R. abziehbild	Calcomania derecha	
	5	8A00 A2783	1	Decal per convogliatore Sx	L.H. transfer	Décalcomanie G.	L. abziehbild	Calcomania izquierda	
	6	8A00 A2778	1	Decal sup. per fianchetto Dx	Upper R.H. transfer	Décalcomanie sup. D.	Obere R. abziehbild	Calcomania sup. derecha	
	7	8A00 A2777	1	Decal sup. per fianchetto Sx	Upper L.H. transfer	Décalcomanie sup. G.	Obere L. abziehbild	Calcomania sup. izquierda	
	8	8000 A2871	2	Adesivo per forcellone	Transfer	Décalcomanie	Abziehbild	Calcomania	
	9	8000 A3197	1	Decal per parastelo Sx	L.H. transfer	Décalcomanie G.	L. Abziehbild	Calcomania izquierda	
	10	8000 A3198	1	Decal per parastelo Dx	R.H. transfer	Décalcomanie D.	R. abziehbild	Calcomania derecha	
	11	8A00 A3113	1	Decal per fianchetto Sx	L.H. transfer	Décalcomanie G.	L. abziehbild	Calcomania izquierda	
	12	8A00 A3114	1	Decal per fianchetto Dx	R.H. transfer	Décalcomanie D.	R. abziehbild	Calcomania derecha	
	13	8000 A2122	1	Decal per parafango posteriore	Transfer	Décalcomanie	Abziehbild	Calcomania	
	14	8000 95761	2	Decal "CATALYTIC"	"CATALYTIC" transfer	Décal. "CATALYTIC"	Abziehbild "CATALYTIC"	Calcomania "CATALYTIC"	

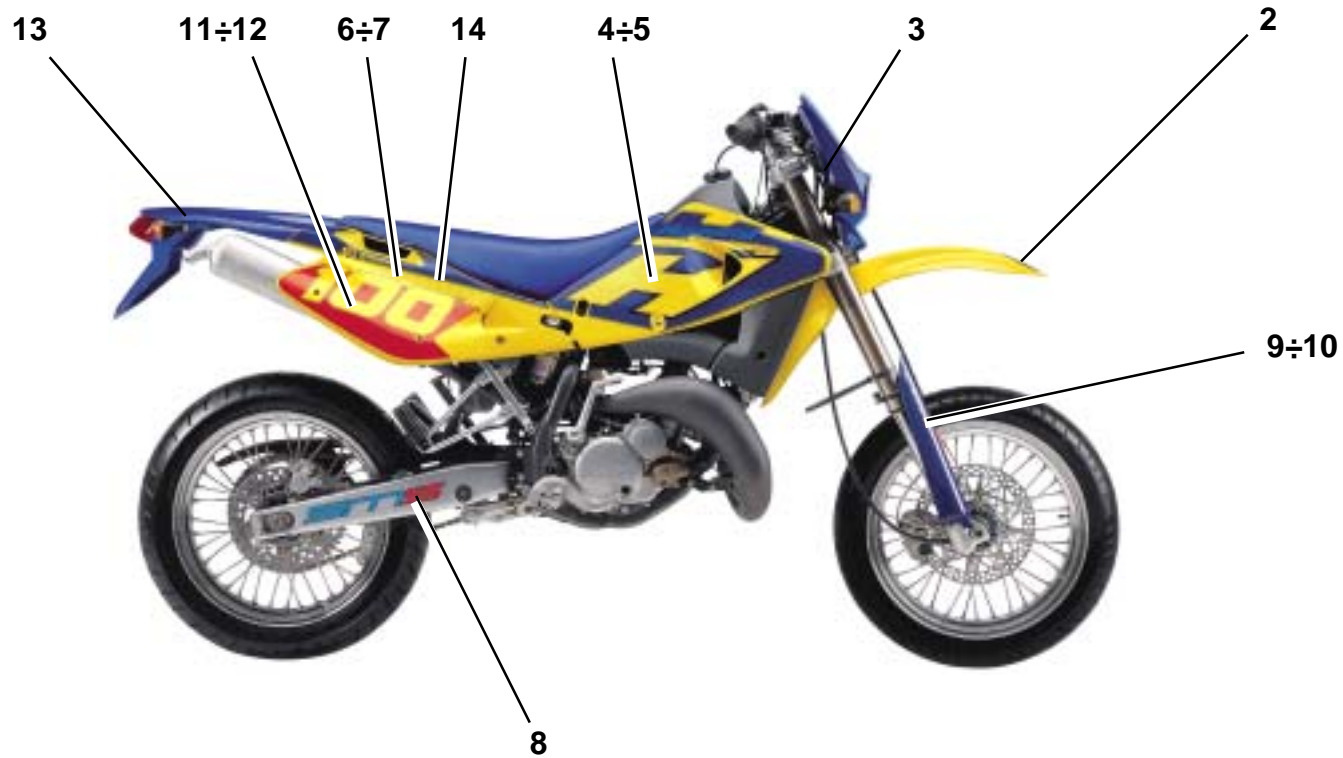

Note Notes Notes Marke Notas	Pos. No. N. Index Pos.	N. Cod. Code No. Nr. Code Code Nr N. Cod.	Q.tà Q.ty Q.te M.ge C.ad	DENOMINAZIONE	NAME	DESIGNATION	BESHREIBUNG	DENOMINACION	Validità Validity Validité Gültig Validez
	2	8000 A3196	1	Decal portafaro	Transfer	Décalcomanie	Abziehbild	Calcomania	
	3	8000 A3195	1	Decal per parafango anteriore	Transfer	Décalcomanie	Abziehbild	Calcomania	
	4	8A00 A2782	1	Decal per convogliatore Dx	R.H. transfer	Décalcomanie D.	R. abziehbild	Calcomania derecha	
	5	8A00 A2783	1	Decal per convogliatore Sx	L.H. transfer	Décalcomanie G.	L. abziehbild	Calcomania izquierda	
	6	8A00 A2778	1	Decal sup. per fianchetto Dx	Upper R.H. transfer	Décalcomanie sup. D.	Obere R. abziehbild	Calcomania sup. derecha	
	7	8A00 A2777	1	Decal sup. per fianchetto Sx	Upper L.H. transfer	Décalcomanie sup. G.	Obere L. abziehbild	Calcomania sup. izquierda	
	8	8000 A2872	2	Adesivo per forcellone	Transfer	Décalcomanie	Abziehbild	Calcomania	
	9	8000 A3197	1	Decal per parastelo Sx	L.H. transfer	Décalcomanie G.	L. Abziehbild	Calcomania izquierda	
	10	8000 A3198	1	Decal per parastelo Dx	R.H. transfer	Décalcomanie D.	R. abziehbild	Calcomania derecha	
	11	8A00 A3113	1	Decal per fianchetto Sx	L.H. transfer	Décalcomanie G.	L. abziehbild	Calcomania izquierda	
	12	8A00 A3114	1	Decal per fianchetto Dx	R.H. transfer	Décalcomanie D.	R. abziehbild	Calcomania derecha	
	13	8000 A2122	1	Decal per parafango posteriore	Transfer	Décalcomanie	Abziehbild	Calcomania	
	14	8000 95761	2	Decal "CATALYTIC"	"CATALYTIC" transfer	Décal. "CATALYTIC"	Abziehbild "CATALYTIC"	Calcomania "CATALYTIC"	

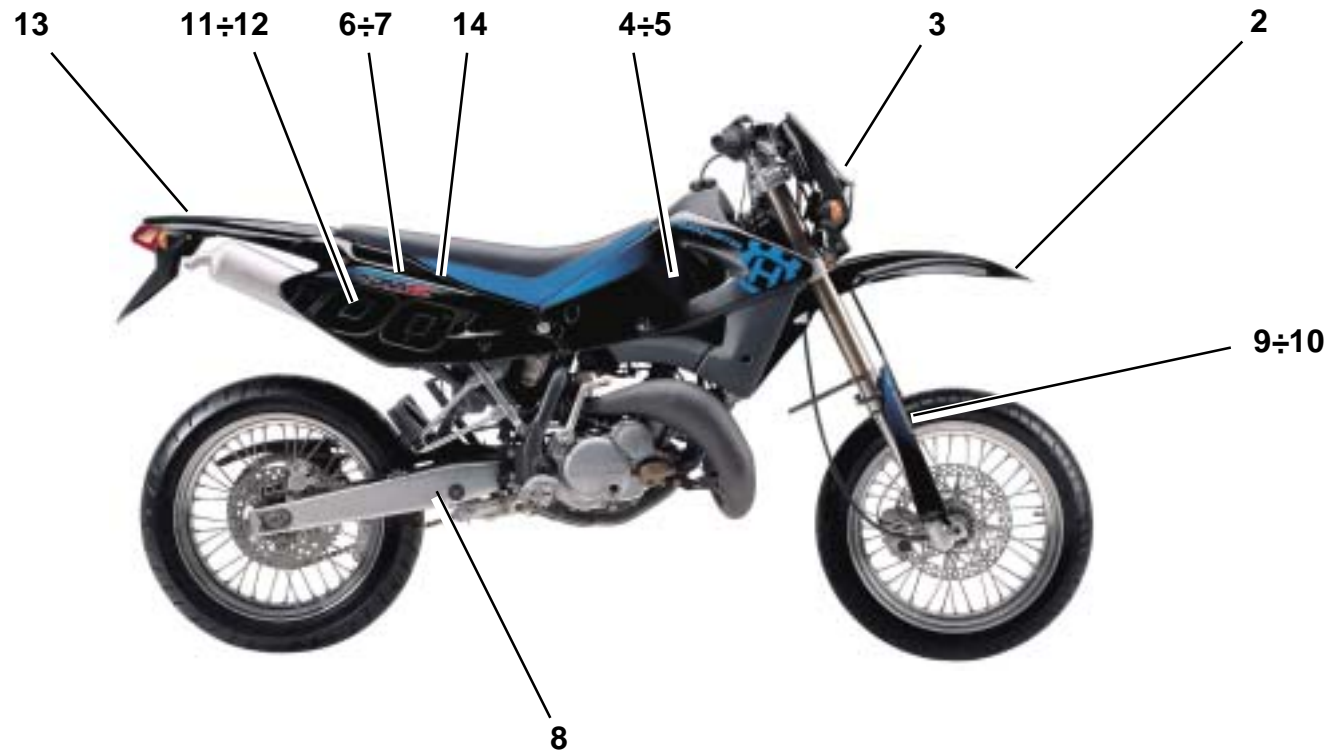

Note Notes Notes Marke Notas	Pos. No. N. Index Pos.	N. Cod. Code No. Nr. Code Code Nr N. Cod.	Q.tà Q.ty Q.te M.ge C.ad	DENOMINAZIONE	NAME	DESIGNATION	BESHREIBUNG	DENOMINACION	Validità Validity Validité Gültig Validez
	2	80A0 A3196	1	Decal portafaro	Transfer	Décalcomanie	Abziehbild	Calcomania	
	3	8000 A0368	1	Decal per parafango anteriore	Transfer	Décalcomanie	Abziehbild	Calcomania	
	4	8000 A0724	1	Decal per convogliatore Dx	R.H. transfer	Décalcomanie D.	R. abziehbild	Calcomania derecha	
	5	8000 A0725	1	Decal per convogliatore Sx	L.H. transfer	Décalcomanie G.	L. abziehbild	Calcomania izquierda	
	6	80A0 A2482	1	Decal sup. per fianchetto Dx	Upper R.H. transfer	Décalcomanie sup. D.	Obere R. abziehbild	Calcomania sup. derecha	
	7	80A0 A2483	1	Decal sup. per fianchetto Sx	Upper L.H. transfer	Décalcomanie sup. G.	Obere L. abziehbild	Calcomania sup. izquierda	
	8	8000 A2872	2	Adesivo per forcellone	Transfer	Décalcomanie	Abziehbild	Calcomania	
	9	80A0 A3197	1	Decal per parastelo Sx	L.H. transfer	Décalcomanie G.	L. Abziehbild	Calcomania izquierda	
	10	80A0 A3198	1	Decal per parastelo Dx	R.H. transfer	Décalcomanie D.	R. abziehbild	Calcomania derecha	
	11	8000 A3713	1	Decal per fianchetto Sx	L.H. transfer	Décalcomanie G.	L. abziehbild	Calcomania izquierda	
	12	8000 A3714	1	Decal per fianchetto Dx	R.H. transfer	Décalcomanie D.	R. abziehbild	Calcomania derecha	
	13	8000 A2122	1	Decal per parafango posteriore	Transfer	Décalcomanie	Abziehbild	Calcomania	
	14	8000 95761	2	Decal "CATALYTIC"	"CATALYTIC" transfer	Décal. "CATALYTIC"	Abziehbild "CATALYTIC"	Calcomania "CATALYTIC"	

DISEGNO DRAWING DESSIN ZEICHNUNG DIBUJO	TAVOLA DRAWING TABLE BILD TABLA	INDEX NO. POS. N. INDICE	DISEGNO DRAWING DESSIN ZEICHNUNG DIBUJO	TAVOLA DRAWING TABLE BILD TABLA	INDEX NO. POS. N. INDICE	DISEGNO DRAWING DESSIN ZEICHNUNG DIBUJO	TAVOLA DRAWING TABLE BILD TABLA	INDEX NO. POS. N. INDICE	DISEGNO DRAWING DESSIN ZEICHNUNG DIBUJO	TAVOLA DRAWING TABLE BILD TABLA	INDEX NO. POS. N. INDICE	DISEGNO DRAWING DESSIN ZEICHNUNG DIBUJO	TAVOLA DRAWING TABLE BILD TABLA	INDEX NO. POS. N. INDICE	DISEGNO DRAWING DESSIN ZEICHNUNG DIBUJO	TAVOLA DRAWING TABLE BILD TABLA	INDEX NO. POS. N. INDICE
000Y A2273	1	4	8000 01199	20	17	8000 29089	7	16	8000 38957	16A	12	8000 45495	19	8	8000 53259	22	20
1511 31701	16	18	8000 01412	16A	13	8000 30319	14	35	8000 39260	3	25	8000 45495	20	10	8000 53322	6	6
1511 33302	16A	22	8000 01688	23	3	8000 30794	12	8	8000 39335	2	12	8000 45495	26	5	8000 53324	5	6
1513 07001	14	2	8000 03271	4	15	8000 31744	8	24	8000 39630	2	16	8000 45498	14	5	8000 53340	6	5
1513 41401	21	10	8000 04551	7	26	8000 31768	8	7	8000 39651		13	8000 45499	21	18	8000 53717	10	13
1513 74301	21	7	8000 05080	23	2	8000 32065	16A	20	8000 40433	2	26	8000 46225	9	10	8000 54141	6	20
1514 10702	21	8	8000 06597	5	19	8000 32388	16	30	8000 40449	8	14	8000 46428	7	18	8000 54427	5	30
1617 95501	4	10	8000 07719	5	15	8000 32854	12	13	8000 40717	25	43	8000 46881	4	17	8000 54507	7	27
1619 69801	1	16	8000 09721	17	24	8000 32855	12	17	8000 40718	13	8	8000 46893	19	16	8000 54895	3	23
60N0 17330	3	1	8000 10314	2	3	8000 33054	1	10	8000 40718	15	17	8000 47496	9	2	8000 55188	3	40
60N1 01140	8	22	8000 11577	11	10	8000 33273	10	11	8000 40718	24	11	8000 47678	5	10	8000 55520	15	25
60N1 02512	5	35	8000 12029	12	42	8000 33373	14	25	8000 40720	14	28	8000 47678	5	33	8000 55532	7	14
60N1 02514	5	37	8000 12029	21	26	8000 34451	5	32	8000 40720	16	9	8000 47773	3	28	8000 55878	23	15
60N1 02515	5	36	8000 12030	12	41	8000 35353	12	29	8000 40722	16A	17	8000 48772	22A	20	8000 55902	18	4
60N1 02518	5	54	8000 12033	12	38	8000 35370	6	22	8000 40724	16A	15	8000 48773	22A	19	8000 56359	25	32
60N1 02557	15	10	8000 12037	12	44	8000 35531	14	39	8000 40813	20	21	8000 48802	19	5	8000 56359	26	29
60N1 04134	20	2	8000 12045	12	31	8000 35876	9	20	8000 41240	20	20	8000 48803	1	2	8000 56377	18	6
60N1 07330	17	14	8000 12048	12	34	8000 36023	8	9	8000 41459	14	16	8000 48814	7	2	8000 56381	20	7
60N1 07335	5	57	8000 12634	22	23	8000 36137	16	7	8000 41513	14	43	8000 48814	19	23	8000 56444	25	29
61N1 15095	2	11	8000 13346	22A	3	8000 36357	5	27	8000 41750	5	51	8000 48856	5	28	8000 56458	10	10
61N1 15192	24	17	8000 17693	10	5	8000 36380	11A	16	8000 42022	16A	16	8000 48916	17	16	8000 56462	4	22
62N0 15676	2	29	8000 18048	25	17	8000 36467	20	9	8000 42022	16B	22	8000 48917	17	5	8000 56722	10	14
62N0 15678	5	49	8000 18648	22A	2	8000 36653		4	8000 42022	16C	9	8000 48966	17	27	8000 56767	23	28
62N1 15504	14	17	8000 18922	10	18	8000 36682	12	28	8000 42023	11	7	8000 49016	5	29	8000 56768	23	27
62N1 15534	25	67	8000 19789	3	3	8000 36685	12	15	8000 42272	25	34	8000 49531	12	46	8000 56800	14	34
62N1 15536	14	23	8000 19789	8	25	8000 36687	12	23	8000 42274	25	26	8000 49642	10	9	8000 57155	18	24
62N1 15547	25	44	8000 20536	16	25	8000 36726	26	9	8000 42349	18	21	8000 49654	22	16	8000 57155	22	7
62N1 15549	13	10	8000 20602	24	20	8000 36727	25	9	8000 42643	5	12	8000 49767	1	8	8000 57167	22	9
62N1 15549	25	1	8000 21198	17	20	8000 37745	20	15	8000 42643	5	26	8000 50005	20	27	8000 57205	25	66
64N1 20048	14	18	8000 21480	18	25	8000 37891	18	26	8000 42781	16A	19	8000 50472	12	18	8000 57401	12	20
64N1 20068	14	10	8000 21480	22	6	8000 37977	15	26	8000 42946	25	6	8000 50569	24	26	8000 57413	12	52
64N1 20068	18	7	8000 21939	5	7	8000 38210	24	27	8000 43382	5	5	8000 50629	2	8	8000 58207	25	33
65N0 21002	11	5	8000 21939	5	23	8000 38211	14	22	8000 43391	14	40	8000 50808	25	20	8000 58378	17	21
66N0 21203	11A	11	8000 22551	18	3	8000 38706	9	5	8000 43592	20	18	8000 51614	1	1	8000 58378	22	13
66N0 21270	22A	22	8000 23981	12	14	8000 38707	7	24	8000 43720	1	11	8000 51745	5	24	8000 58660	12	49
66N0 21272	23	24	8000 23983	12	40	8000 38707	9	7	8000 43824	1	9	8000 51746	5	25	8000 59034	3	27
66N0 21309	17	23	8000 23985	12	19	8000 38708	9	3	8000 43928	3	30	8000 51862	23	2	8000 59287	3	38
69N4 29004	22A	9	8000 24962	10	6	8000 38748	20	16	8000 43928	23	18	8000 51957	22A	15	8000 59289	16	8
69N4 29005	23	7	8000 24962	11	4	8000 38767	16A	23	8000 44059	12	32	8000 51986	12	11	8000 59289	16	24
6BN0 21506	7	10	8000 25053	24	9	8000 38797	17	12	8000 44240	25	18	8000 51987	12	12	8000 59394	25	46
6BN0 21506	11A	18	8000 27521	5	45	8000 38799	17	15	8000 44240	26	4	8000 52078	12	50	8000 59801	4	35
8000 01199	6	21	8000 28959	6	2	8000 38956	16A	5	8000 45042	19	2	8000 53259	18	29	8000 59803	4	26

DISEGNO DRAWING DESSIN ZEICHNUNG DIBUJO	TAVOLA DRAWING TABLE BILD TABLA	INDEX NO. POS. N. INDICE	DISEGNO DRAWING DESSIN ZEICHNUNG DIBUJO	TAVOLA DRAWING TABLE BILD TABLA	INDEX NO. POS. N. INDICE	DISEGNO DRAWING DESSIN ZEICHNUNG DIBUJO	TAVOLA DRAWING TABLE BILD TABLA	INDEX NO. POS. N. INDICE	DISEGNO DRAWING DESSIN ZEICHNUNG DIBUJO	TAVOLA DRAWING TABLE BILD TABLA	INDEX NO. POS. N. INDICE	DISEGNO DRAWING DESSIN ZEICHNUNG DIBUJO	TAVOLA DRAWING TABLE BILD TABLA	INDEX NO. POS. N. INDICE	DISEGNO DRAWING DESSIN ZEICHNUNG DIBUJO	TAVOLA DRAWING TABLE BILD TABLA	INDEX NO. POS. N. INDICE
8000 59839	16A	11	8000 62728	6	19	8000 66954	7	23	8000 69429	20	23	8000 73650	8	26	8000 76074	5	40
8000 60033	24	2	8000 62728	7	1	8000 66962	9	23	8000 69486	22A	1	8000 73834	25	35	8000 76075	5	41
8000 60404	18	19	8000 62728	9	11	8000 66968	6	7	8000 69549	13	2	8000 73894	18	11	8000 76076	5	42
8000 60404	22	19	8000 62728	13	14	8000 66972	6	18	8000 70024	13	7	8000 74181	22	17	8000 76079	11	8
8000 60873	4	31	8000 62728	19	11	8000 66973	6	13	8000 70215	9	16	8000 74258	24	25	8000 76100	11	9
8000 60969	24	22	8000 62728	19	13	8000 67011	9	18	8000 70216	9	15	8000 74259	24	24	8000 76132	9	17
8000 61068	17	25	8000 62728	25	8	8000 67013	11A	8	8000 70217	9	14	8000 74372	16A	6	8000 76133	9	19
8000 61078	18	14	8000 62728	25	45	8000 67015	11A	2	8000 70277	25	3	8000 74414	6	1	8000 76262	5	50
8000 61102	5	43	8000 62728	26	3	8000 67016	11A	3	8000 70309	7	11	8000 74415	11A	13	8000 76283	16	2
8000 61313	16	12	8000 62728	26	10	8000 67017	11A	1	8000 70467	7	4	8000 74725	11	1	8000 76338	18	10
8000 61313	19	4	8000 62729	4	28	8000 67020	11A	6	8000 70468	7	17	8000 74758	6	15	8000 76605	9	12
8000 61313	24	12	8000 62729	6	9	8000 67024	10	1	8000 70549	7	7	8000 74815	16	6	8000 76687	17	3
8000 61355	15	42	8000 62729	17	17	8000 67025	10	4	8000 70550	7	6	8000 74816	16	21	8000 76688	17	2
8000 61357	14	31	8000 62729	19	18	8000 67045	11A	12	8000 70551	7	5	8000 74836	5	17	8000 77052	14	29
8000 62200	5	31	8000 62729	22	24	8000 67047	11A	14	8000 70552	7	12	8000 75166	16	8	8000 77347	9	1
8000 62341	21	1	8000 62730	9	25	8000 67625	2	28	8000 70554	7	13	8000 75271	17	6	8000 77360	15	31
8000 62390	3	26	8000 62730	25	19	8000 67997	3	22	8000 70627	2	13	8000 75310	17	8	8000 77362	15	29
8000 62400	16	20	8000 62731	4	11	8000 67997	5	22	8000 70635	2	17	8000 75354	14	41	8000 77378	15	24
8000 62613	23	21	8000 62733	15	9	8000 67997	15	13	8000 70696	18	5	8000 75390	7	3	8000 77385	14	27
8000 62651	24	8	8000 62733	22	12	8000 67997	16	14	8000 70966	15	28	8000 75415	5	48	8000 77429	3	34
8000 62675	14	12	8000 62795	16	10	8000 67997	24	18	8000 71445	18	27	8000 75477	24	23	8000 77735	17	18
8000 62676	14	13	8000 62796	3	39	8000 68277	4	7	8000 71445	22	14	8000 75479	13	4	8000 77736	17	4
8000 62705	3	24	8000 62796	15	6	8000 68278		3	8000 71578	25	5	8000 75806	3	29	8000 77737	17	11
8000 62725	11A	19	8000 64168	12	26	8000 68516	15	8	8000 71620	16	13	8000 75836	24	19	8000 77827	24	6
8000 62725	13	9	8000 64170	12	47	8000 68860	8	2	8000 71621	16	4	8000 75962	8	1	8000 77841	5	20
8000 62725	14	24	8000 64296	2	27	8000 69035	20	26	8000 71623	16	19	8000 75963	8	11	8000 77884	22A	14
8000 62725	14	36	8000 65884	9	6	8000 69036	20	5	8000 71759	24	5	8000 75964	8	10	8000 78031	14	37
8000 62725	14	42	8000 65921	9	24	8000 69056	14	33	8000 72168	16A	21	8000 75965	8	8	8000 78164	18	23
8000 62725	18	18	8000 65922	4	9	8000 69113	21	19	8000 72431	9	12	8000 75966	8	5	8000 78727	5	55
8000 62725	21	17	8000 65923	4	2	8000 69125	18	2	8000 72494	25	4	8000 75967	8	3	8000 79004	15	22
8000 62725	25	47	8000 65935	4	4	8000 69148	19	15	8000 72641	13	3	8000 75968	8	12	8000 79005	15	23
8000 62726	16B	24	8000 65935	10	2	8000 69149	19	7	8000 72648	24	10	8000 75969	8	20	8000 79006	15	32
8000 62726	16C	11	8000 65955	8	21	8000 69150	14	26	8000 72800	8	6	8000 75970	8	19	8000 79007	15	30
8000 62726	18	12	8000 65975	9	8	8000 69282	15	14	8000 72874	16	28	8000 75971	8	18	8000 79008	15	39
8000 62726	19	14	8000 66238	20	3	8000 69282	16	5	8000 72884	16	3	8000 75972	8	17	8000 79015	1	5
8000 62726	21	20	8000 66565	11	6	8000 69315	15	4	8000 72889	5	34	8000 75973	8	16	8000 79016	1	6
8000 62726	24	14	8000 66651	14	19	8000 69428	24	4	8000 73021	6	10	8000 75974	8	15	8000 79017	1	7
8000 62727	20	24	8000 66652	14	30	8000 69429	13	5	8000 73140	14	6	8000 75975	8	13	8000 79065	22	21
8000 62727	25	31	8000 66774	17	10	8000 69429	16B	23	8000 73348	16A	2	8000 75984	4	20	8000 79066	18	22
8000 62727	25	36	8000 66774	25	65	8000 69429	16C	10	8000 73394	16A	18	8000 76002	16	27	8000 79066	22	22
8000 62728	4	13	8000 66946	11A	15	8000 69429	19	17	8000 73591	26	7	8000 76026	18	9	8000 79068	22	3
8000 62728	6	16	8000 66952	5	11	8000 69429	19	21	8000 73649	8	23	8000 76032	18	15	8000 79069	22	4

DISEGNO DRAWING DESSIN ZEICHNUNG DIBUJO	TAVOLA DRAWING TABLE BILD TABLA	INDEX NO. POS. N. INDICE	DISEGNO DRAWING DESSIN ZEICHNUNG DIBUJO	TAVOLA DRAWING TABLE BILD TABLA	INDEX NO. POS. N. INDICE	DISEGNO DRAWING DESSIN ZEICHNUNG DIBUJO	TAVOLA DRAWING TABLE BILD TABLA	INDEX NO. POS. N. INDICE	DISEGNO DRAWING DESSIN ZEICHNUNG DIBUJO	TAVOLA DRAWING TABLE BILD TABLA	INDEX NO. POS. N. INDICE	DISEGNO DRAWING DESSIN ZEICHNUNG DIBUJO	TAVOLA DRAWING TABLE BILD TABLA	INDEX NO. POS. N. INDICE	DISEGNO DRAWING DESSIN ZEICHNUNG DIBUJO	TAVOLA DRAWING TABLE BILD TABLA	INDEX NO. POS. N. INDICE
8000 79070	22	5	8000 87562	25	22	8000 91865	16B	5	8000 94754	22A	8	8000 99475	4	38	8000 A3198	27	10
8000 79072	18	16	8000 87813	5	44	8000 91869	16B	13	8000 94757	23	6	8000 99583	26	35	8000 A3198	28	10
8000 79075	18	28	8000 88139	25	28	8000 91870	16B	14	8000 94806	21	23	8000 99584	26	34	8000 A3713	29	11
8000 79077	4	25	8000 88173	26	1	8000 91871	16B	15	8000 94808	21	11	8000 99585	26	33	8000 A3714	29	12
8000 79560	2	25	8000 88259	26	2	8000 91872	16B	19	8000 94968	16C	7	8000 99749/1	2	2	80A0 12041	12	4
8000 79561	4	1	8000 88334	26	25	8000 91971	24	3	8000 94969	16C	13	8000 99749/2	2	2	80A0 19963	23	13
8000 79790	23	28	8000 88335	26	26	8000 92215	4	36	8000 94970	16C	5	8000 99749/3	2	2	80A0 42349	20	14
8000 79973	11A	20	8000 88336	26	6	8000 92216	4	24	8000 94971	16C	2	8000 99750	2	4	80A0 47665	7	25
8000 83043	5	46	8000 88337	26	11	8000 92693	22A	7	8000 94972	16C	3	8000 99755	3	8	80A0 59299	16	33
8000 83049	3	31	8000 88386	24	6	8000 92693	22A	8	8000 94973	16C	4	8000 99767	5	16	80A0 64805	10	16
8000 83056	2	23	8000 88543	24	21	8000 92703	23	6	8000 94974	16C	6	8000 A0051	19	6	80A0 69551	16B	25
8000 83066	2	5	8000 88545	24	3	8000 92788	21	5	8000 94975	16C	1	8000 A0368	29	3	80A0 69551	16C	12
8000 83068	2	20	8000 88648	24	7	8000 92797	22A	12	8000 95008	16B	1	8000 A0545	19	12	80A0 73456	16	15
8000 83071	2	6	8000 88680	23	1	8000 92797	23	11	8000 95248	22	15	8000 A0633	15	40	80A0 74388	16	22
8000 83077	3	14	8000 88739	22A	2	8000 92817	17	7	8000 95249	26	17	8000 A0724	29	4	80A0 75097	15	43
8000 83078	3	18	8000 88759	25	50	8000 92820	7	28	8000 95341	23	6	8000 A0725	29	5	80A0 89953	14	38
8000 83085	7	3	8000 88810	2	7	8000 92896	5	56	8000 95419	25	2	8000 A0872	4	33	80A0 89962	14	7
8000 83090	3	11	8000 88822	7	8	8000 92910	2	9	8000 95629	22A	11	8000 A0872	4	34	80A0 A0633	15	40
8000 83095	11A	5	8000 88823	7	8	8000 93017	20	12	8000 95644	25	64	8000 A0953	25	14	80A0 A2482	29	6
8000 83108	3	7	8000 88828	5	3	8000 93883	20	11	8000 95645	25	60	8000 A1103	5	1	80A0 A2483	29	7
8000 83109	3	10	8000 88862	20	1	8000 94009	20	19	8000 95646	25	61	8000 A1240	2	21	80A0 A3196	29	2
8000 83110	3	9	8000 88887	23	14	8000 94010	20	13	8000 95648	25	27	8000 A1242	2	1	80A0 A3197	29	9
8000 83113	3	13	8000 88889	22A	23	8000 94098	20	8	8000 95649	25	24	8000 A1473	7	19	80A0 A3198	29	10
8000 83114	3	2	8000 89030	1	3	8000 94120	25	16	8000 95650	25	59	8000 A2122	27	13	80B0 43928	2	18
8000 83116	3	12	8000 89085	16B	7	8000 94121	25	15	8000 95727	19	24	8000 A2122	28	13	80B0 63846	12	10
8000 83118	3	15	8000 89086	16B	8	8000 94131	4	18	8000 95761	27	14	8000 A2122	29	13	80B0 83024	4	8
8000 83119	3	17	8000 89097	16B	16	8000 94466	3	33	8000 95761	28	14	8000 A2871	27	8	80C0 35357	12	9
8000 83121	3	36	8000 89098	16B	17	8000 94595	25	30	8000 95761	29	14	8000 A2872	28	8	80C0 36681	12	1
8000 83122	3	6	8000 89099	16B	18	8000 94652	2	22	8000 95891	16B	10	8000 A2872	29	8	80C0 69337	15	11
8000 83123	3	5	8000 89572	23	26	8000 94653	2	30	8000 95892	16B	12	8000 A2916	1	15	80C0 69338	15	12
8000 83395	15	2	8000 89882	14	8	8000 94657	12	51	8000 95895	16B	3	8000 A2917	1	12	80C0 87060	25	25
8000 83590	5	4	8000 90197	25	22	8000 94658	2	9	8000 96482	22A	10	8000 A2918	1	13	80D0 36681	12	1
8000 84176	14	11	8000 90614	4	40	8000 94662	14	32	8000 96563	26	17	8000 A3000	22A	1	80F0 12032	12	7
8000 85220	17	26	8000 90682	12	27	8000 94680	4	41	8000 96739	10	17	8000 A3001	23	1	80F0 87059	19	3
8000 85932	18	30	8000 90719	25	48	8000 94681	4	21	8000 97527	22A	1	8000 A3002	23	2	80F0 87060	25	25
8000 85999	22	18	8000 90877	25	51	8000 94682	4	19	8000 97615	24	29	8000 A3003	22A	2	80F0 87060	25	25
8000 86751	3	37	8000 91524	22A	6	8000 94696	22A	10	8000 97726	15	36	8000 A3195	27	3	80G0 12041	12	4
8000 86785	3	33	8000 91527	23	5	8000 94700	23	8	8000 97727	15	19	8000 A3195	28	3	80G0 12041	21	24
8000 86981	2	15	8000 91856	16B	11	8000 94709	22A	6	8000 98213	5	47	8000 A3196	27	2	80G0 69337	15	11
8000 87038	15	27	8000 91861	16B	20	8000 94713	23	5	8000 98240	26	32	8000 A3196	28	2	80G0 69337	15	11
8000 87150	12	16	8000 91862	16B	2	8000 94721	10	12	8000 98241	26	31	8000 A3197	27	9	80G0 69338	15	12
8000 87152	18	17	8000 91864	16B	4	8000 94754	22A	7	8000 98431	1	14	8000 A3197	28	9	80G0 69338	15	12

DISEGNO DRAWING DESSIN ZEICHNUNG DIBUJO	TAVOLA DRAWING TABLE BILD TABLA	INDEX NO. POS. N. INDICE	DISEGNO DRAWING DESSIN ZEICHNUNG DIBUJO	TAVOLA DRAWING TABLE BILD TABLA	INDEX NO. POS. N. INDICE	DISEGNO DRAWING DESSIN ZEICHNUNG DIBUJO	TAVOLA DRAWING TABLE BILD TABLA	INDEX NO. POS. N. INDICE	DISEGNO DRAWING DESSIN ZEICHNUNG DIBUJO	TAVOLA DRAWING TABLE BILD TABLA	INDEX NO. POS. N. INDICE	DISEGNO DRAWING DESSIN ZEICHNUNG DIBUJO	TAVOLA DRAWING TABLE BILD TABLA	INDEX NO. POS. N. INDICE	DISEGNO DRAWING DESSIN ZEICHNUNG DIBUJO	TAVOLA DRAWING TABLE BILD TABLA	INDEX NO. POS. N. INDICE
80G0 87059	19	3	8A00 67997	3	32	8A00 A0051	19	6	8B00 69429	25	10	8D00 75703	23	16			
80T0 36683	12	2	8A00 67997	15	41	8A00 A2777	27	7	8B00 70379	21	9	8E00 01049	11A	10			
8A00 01815	14	9	8A00 67997	16	34	8A00 A2777	28	7	8B00 73458	14	4	8E00 04551	7	26			
8A00 04883	4	3	8A00 67997	22	10	8A00 A2778	27	6	8B00 78997	15	35	8E00 18282	11A	4			
8A00 18246	25	13	8A00 69138	16A	14	8A00 A2778	28	6	8B00 79785	23	27	8E00 32069	5	52			
8A00 19946	11A	9	8A00 69282	16	26	8A00 A2782	27	4	8B00 81884	19	22	8E00 34292	4	5			
8A00 20182	16	31	8A00 71154	5	2	8A00 A2782	28	4	8B00 82879	22A	3	8E00 58865	3	19			
8A00 23186	21	2	8A00 72387	15	7	8A00 A2783	27	5	8B00 82879	23	3	8E00 64938	23	19			
8A00 25044	7	20	8A00 73458	14	3	8A00 A2783	28	5	8B00 83068	2	20	8E00 67545	16	29			
8A00 26846	23	20	8A00 73622	13	1	8A00 A3113	27	11	8B00 87148	12	6	8E00 67997	3	16			
8A00 31386	7	15	8A00 74372	16A	4	8A00 A3113	28	11	8B00 87148	21	25	8E00 68860	8	2			
8A00 33272	10	8	8A00 74794	16	1	8A00 A3114	27	12	8B00 88884	22A	16	8E00 99475	13	12			
8A00 36849	7	21	8A00 75042	22A	18	8A00 A3114	28	12	8B00 94806	21	23	8F00 28960	4	6			
8A00 36984	16	17	8A00 75153	16A	3	8AA0 36237	16A	24	8B00 95638	14	14	8F00 28960	10	3			
8A00 37947	13	11	8A00 75153	16A	10	8AA0 65340	24	1	8B00 99475	4	16	8F00 68860	8	2			
8A00 38287	11A	17	8A00 75432	14	20	8AA0 70581	24	15	8B00 99475	4	43	8F00 95647	25	63			
8A00 39651		13	8A00 76023	17	9	8AA0 79083	16B	6	8B00 A0050	19	1	8G00 04551	7	26			
8A00 46226	9	9	8A00 76024	22	1	8AA0 88866	19	9	8BA0 70558	15	15	8G00 49525	12	3			
8A00 53248	5	8	8A00 76025	22	8	8AA0 88867	19	10	8C00 04551	7	26	8G00 79785	23	27			
8A00 54164	5	9	8A00 76774	17	19	8AA0 88868	20	6	8C00 26846	23	20	8N00 68873	10	7			
8A00 55241	18	11	8A00 78996	15	18	8AA0 88869	20	22	8C00 40796	23	17	8N00 73458	14	3			
8A00 55241	22A	17	8A00 79067	22	2	8AB0 76028	16	16	8C00 43716	4	23	8P00 73458	14	4			
8A00 55903	18	13	8A00 81900	10	15	8AB0 88866	19	9	8C00 67997	16	23	8S00 67545	4	14			
8A00 56768	23	27	8A00 83056	2	24	8AB0 88867	19	10	8C00 68860	8	2	8S00 68873	20	25			
8A00 57446	25	50	8A00 83068	2	20	8AB0 88868	20	6	8C00 70266	18	20						
8A00 61261	8	4	8A00 85998	22	11	8AB0 88869	20	22	8C00 73541	21	3						
8A00 62797	16A	8	8A00 86938	23	9	8AC0 66947	6	17	8C00 94806	21	23						
8A00 62797	16B	21	8A00 88873	25	11	8B00 26846	23	10	8C00 95638	14	14						
8A00 62797	16C	8	8A00 88884	22A	16	8B00 42029	16A	7	8CA0 A0545	19	12						
8A00 65503	15	3	8A00 89882	14	8	8B00 43715	4	29	8D00 10789	11A	7						
8A00 65845	7	22	8A00 90334	15	1	8B00 49525	12	3	8D00 26846	23	10						
8A00 65895	9	22	8A00 92301	17	1	8B00 55507	12	48	8D00 55507	12	48						
8A00 65955	8	21	8A00 92413	23	12	8B00 56707	17	13	8D00 58865	3	20						
8A00 66525	6	12	8A00 92792	22A	21	8B00 65955	8	21	8D00 59802	4	27						
8A00 66550	11	2	8A00 94119	25	12	8B00 66525	15	16	8D00 61085	23	1						
8A00 66661	16	11	8A00 94806	21	23	8B00 66525	24	13	8D00 64938	23	19						
8A00 66953	5	13	8A00 95008	16B	1	8B00 66525	24	16	8D00 68157	16A	1						
8A00 67545	6	8	8A00 95647	25	62	8B00 67545	4	12	8D00 68860	8	2						
8A00 67545	20	4	8A00 97976	14	15	8B00 67545	26	3	8D00 69634	26	30						
8A00 67545	21	6	8A00 98229	14	1	8B00 68570	17	22	8D00 70034	25	23						
8A00 67545	21	21	8A00 99475	4	42	8B00 68860	8	2	8D00 70379	21	22						
8A00 67997	3	4	8A00 A0050	19	1	8B00 69056	14	21	8D00 73623	13	6						